

2018 PARTS CATALOG



TOHATSU

Feel the Wind™

BFT 250A Model

OB NO.002-14ZX2-0AH 1712 US

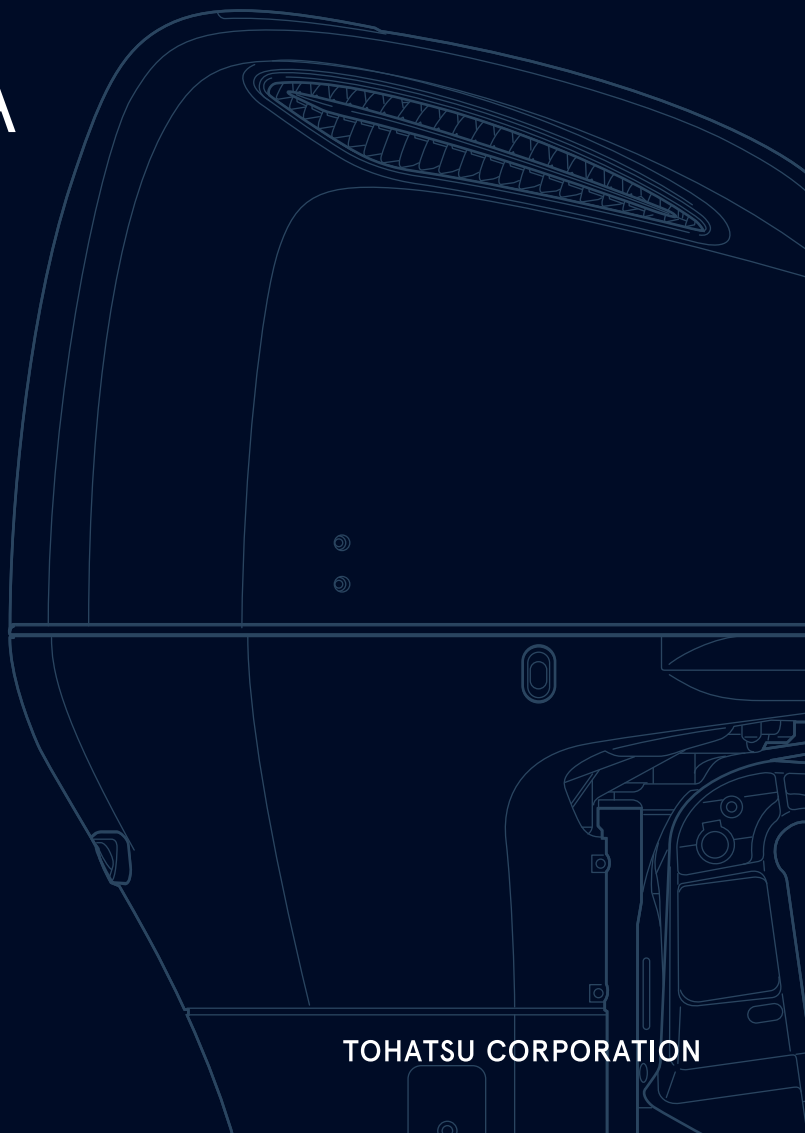

TOHATSU CORPORATION

Instruction for use of parts catalogue

- **This parts catalogue was prepared based on the latest information available as of December 1, 2017.**
- See the Service Bulletin for any revision that is made after December 1, 2017.
- **Always specify the part number when ordering a part.**
 - Check the model, type, serial numbers, color, maker, and the size as needed before ordering a part.
 - Note that the illustrations (part drawings) can differ from the actual parts in shape.
Illustrations are given just to help you to refer to the parts.
- **When modifications or additions to this parts catalogue are made, a revised edition will be issued at an appropriate time, with successively progressing revision numbers on the cover. We recommend obtaining such revisions in order to keep your parts catalogue up-to-date at all times.**

Initial version issue date December 1, 2017

CONTENTS

E-1	CYLINDER HEAD COVER	1
E-3	CYLINDER BLOCK	3
E-3-10	CRANKCASE	7
E-4	EXHAUST MANIFOLD/THERMOSTAT	9
E-5	OIL PUMP/FLYWHEEL	11
E-6	OIL PAN	13
E-6-10	MOUNT CASE	15
E-6-20	MOUNT CASE BOLT	19
E-7	CRANKSHAFT/PISTON	21
E-9	CYLINDER HEAD	25
E-9-10	CAMSHAFT/ROCKER ARM	27
E-13	TIMING BELT	29
E-13-10	TIMING BELT COVER	33
E-14	FUEL PIPE/INJECTOR	35
E-14-10	INTAKE MANIFOLD	39
E-15	THROTTLE BODY	41
E-18	VAPOR SEPARATOR ASSY	43
E-18-1	WATER SEPARATOR/FUEL STRAINER	47
E-18-10	PIPING	51
E-19	A.C.GENERATOR	53
E-20	SPARK PLUG	55
E-20-10	ELECTRONIC CONTROL UNIT	57
E-21	STARTER MOTOR	59
F-2	SHIFT SHAFT	63
F-3	GEAR CASE	67
F-3-10	GEAR CASE ASSY	69
F-3-20	EXTENSION CASE	71
F-4	WATER PUMP/VERTICAL SHAFT	77
F-5	PROPELLER SHAFT	81
F-5-1	PROPELLER SHAFT (COUNTER ROTATION)	85
F-6	FUEL TUBE	89
F-7	WIRE HARNESS	91
F-7-10	STARTER CABLE	93
F-7-20	FUSE BOX/RELAY	95
F-8	ENGINE COVER	97
F-8-10	FR.COVER BRACKET/FR.LOCK SHAFT	99
F-8-20	FUEL TUBE (2)	103
F-10	STERN BRACKET/SWIVEL CASE	105
F-11	POWER TRIM-TILT	111
F-12	LABEL	115
F-13	TOOL	117
FOP-1	REMOTE CONTROL (TOP MOUNT SINGLE TYPE) (RIGHT)	119
FOP-1-2	REMOTE CONTROL (TOP MOUNT DUAL TYPE) (RIGHT)	123
FOP-1-4	REMOTE CONTROL (FLUSH MOUNT DUAL TYPE) (RIGHT)	127
FOP-1-6	REMOTE CONTROL (HI-LEX) (HANDLE CAP = GRAY)	129
FOP-1-7	REMOTE CONTROL (NHK MEC) (HANDLE CAP = CHROME)	135
FOP-3	METER	141
FOP-5	BOLT KIT	143
FOP-6	SWITCH PANEL KIT	145
FOP-7	CONTROL PANEL (1)	147
FOP-7-1	CONTROL PANEL (2)	149
FOP-8	PROPELLER	151
FOP-9	TRIM ADJUST PLATE SET	153
FOP-10	INTERFACE CABLE KIT	155
FOP-12	GEAR CASE KIT	157
FOP-13	PANEL INTERFACE CABLE SET	159
INDEX		161
INDEX (Parts Number)		167

How to check the part block and serial numbers

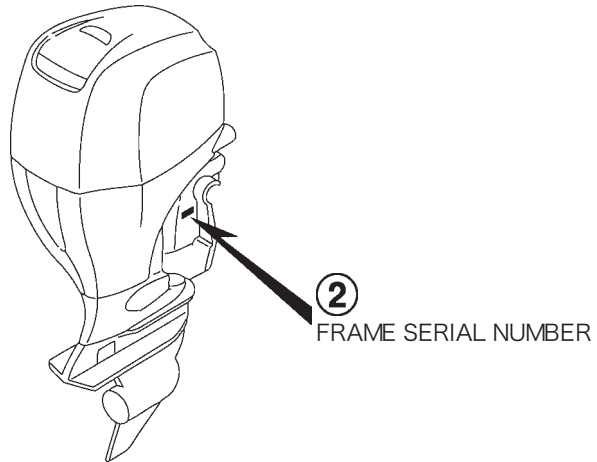
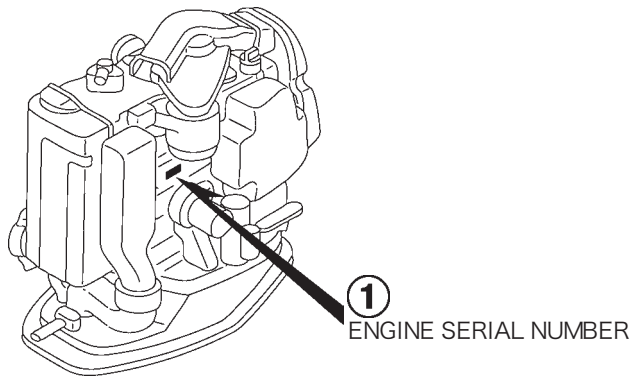
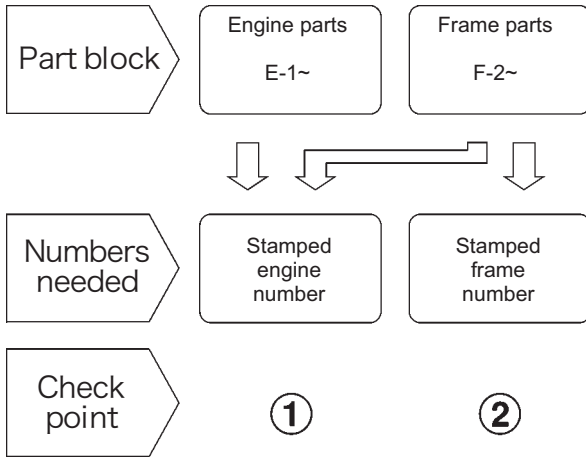

Models, parts catalogue codes and applicable serial numbers

- Models, parts catalogue codes and applicable serial Nos. given in this parts catalogue can be identified as follows.

Model	Type	Parts catalogue type	Engine		Applicable engine serial No.	Applicable frame serial No.
			Model	Type		
BFT 250A	LA	LA	BF 250A	SE1	BEBJJ-1000001~	BBJJ-6000001~
	XA	XA				
	XCA	XCA				BBJJ-7000001~
	XXA	XXA				BBJJ-6000001~
	XXCA	XXCA				BBJJ-7000001~

Features of each type

- See the following table for the features of each type. (Items in brackets are optional)

Specifications		Model	BFT 250A				
		Type	LA	XA	XCA	XXA	XXCA
Transom height	508 mm	●					
	635 mm		●	●			
	762 mm				●	●	
Gear case cover				●		●	
Trim tab		●	●		●		
Counter rotation				●		●	

Fuel hose, general purpose hoses and vinyl hose

- The standard part fuel hose, general purpose hose and vinyl hose may be substituted by the coiled bulk part.
- When ordering the standard part fuel hose, general purpose hose and vinyl hose use the bulk part number written in the parts catalog in brackets () underneath the part name.
- When exchanging the hose, cut and use at the specified length as mentioned in the part name. (For the method of cutting the bulk part, and method of filling out orders etc., please refer to the instructions issued with the bulk part.)

Bulk part number of fuel hose, general purpose hose and vinyl hose.

Example: 95001-75001-50M

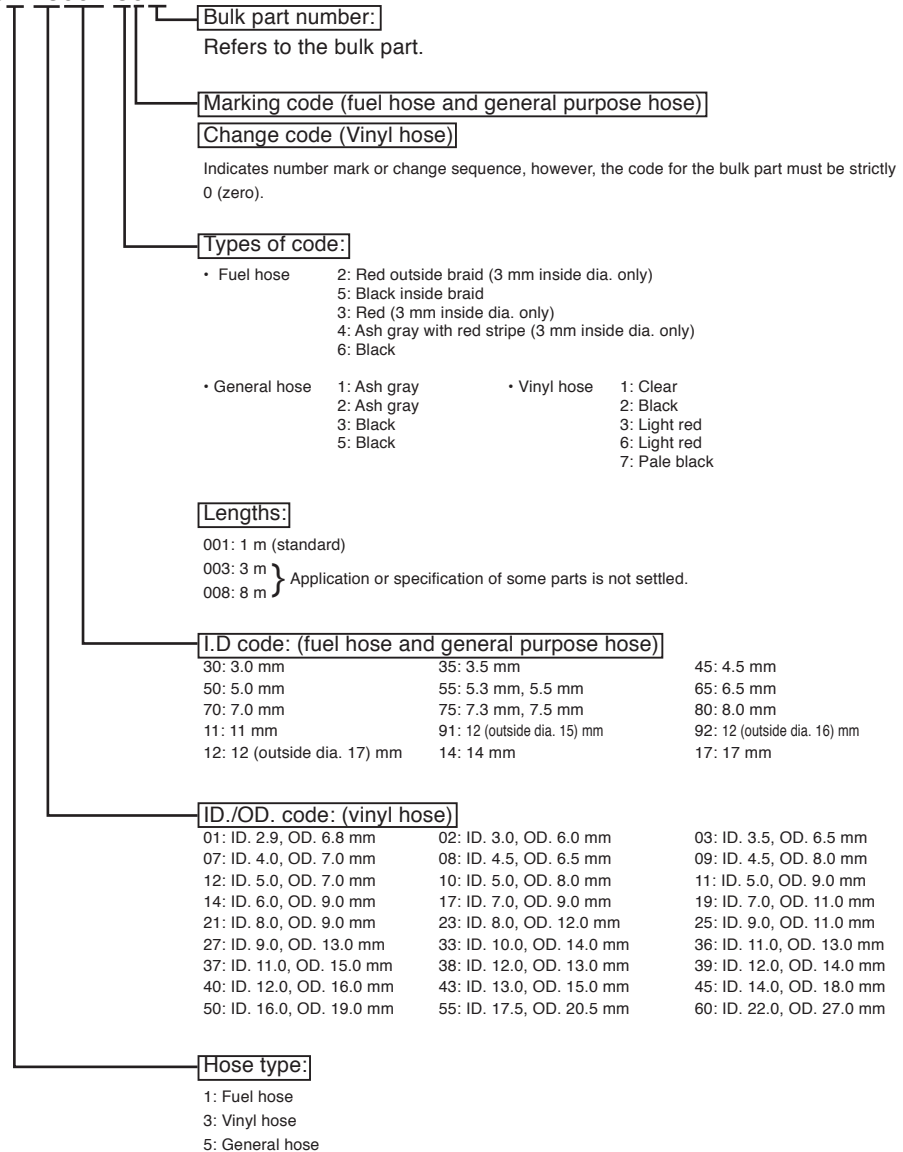

CAUTION: It is DANGEROUS to confuse the fuel hose with the general purpose hose or vinyl hose.

Never use a general purpose hose or vinyl hose in place of a fuel hose or vice versa. Always use the correct bulk part in the parts catalogue, according to the service manual or the instructions issued with the bulk part.

E-1 CYLINDER HEAD COVER

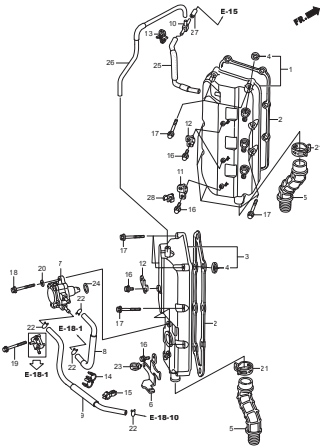

E-3 CYLINDER BLOCK

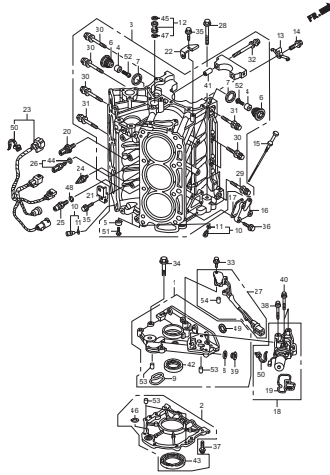

E-3-10 CRANKCASE

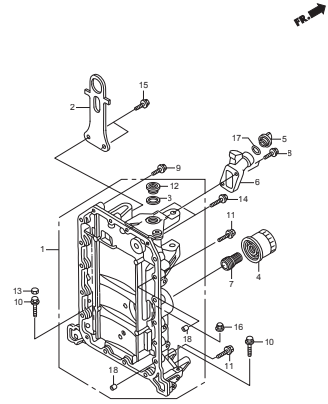

E-4 EXHAUST MANIFOLD/THERMOSTAT

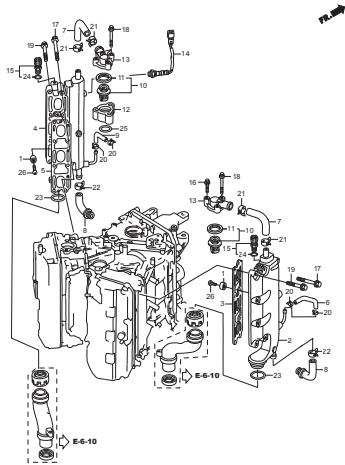

E-5 OIL PUMP/FLYWHEEL

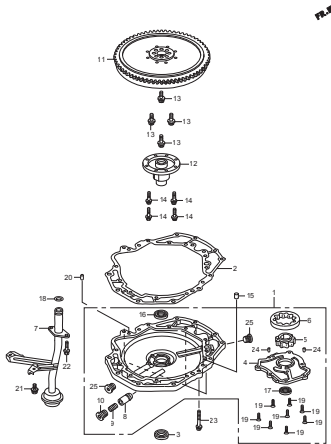

E-6 OIL PAN

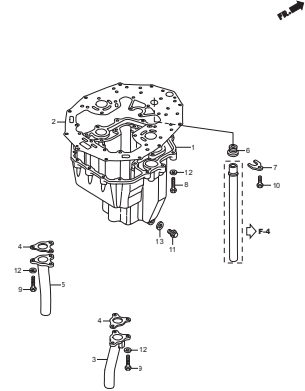

E-6-10 MOUNT CASE

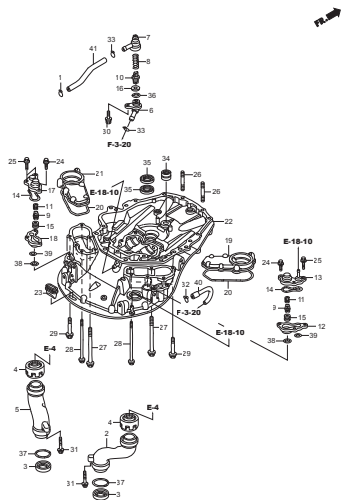

E-6-20 MOUNT CASE BOLT

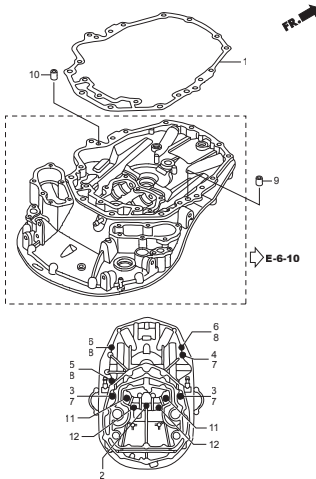

E-7 CRANKSHAFT/PISTON

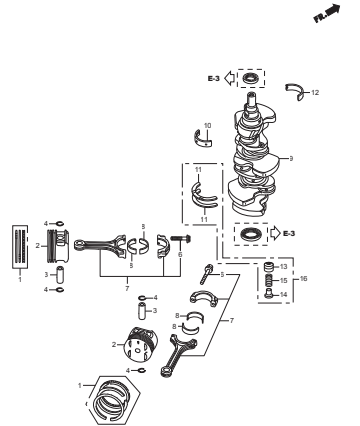

E-9 CYLINDER HEAD

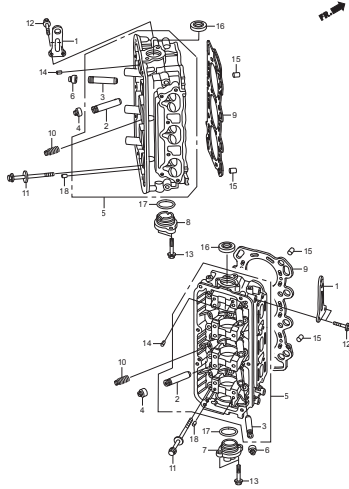

E-9-10 CAMSHAFT/ROCKER ARM

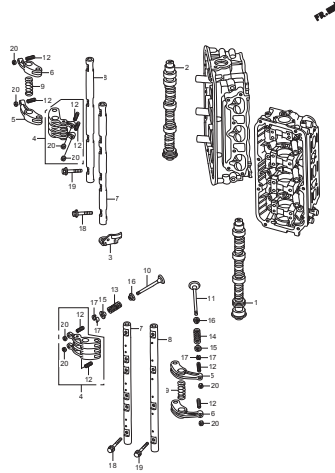

E-13 TIMING BELT

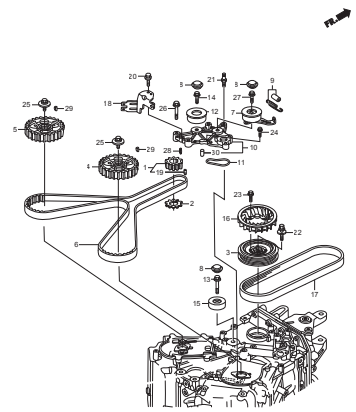

E-13-10 TIMING BELT COVER

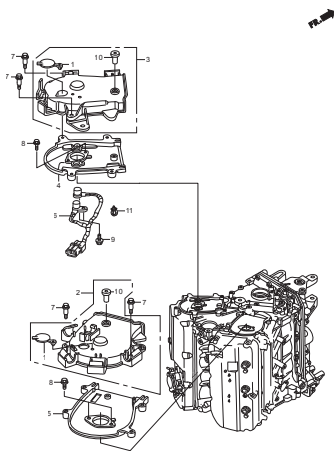

E-14 FUEL PIPE/INJECTOR

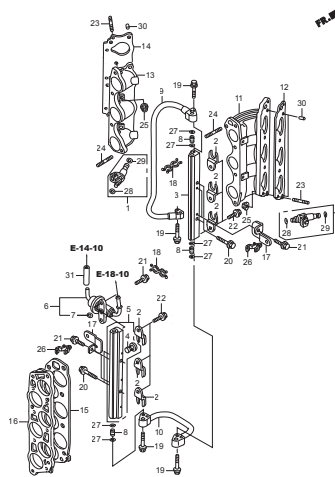

E-14-10 INTAKE MANIFOLD

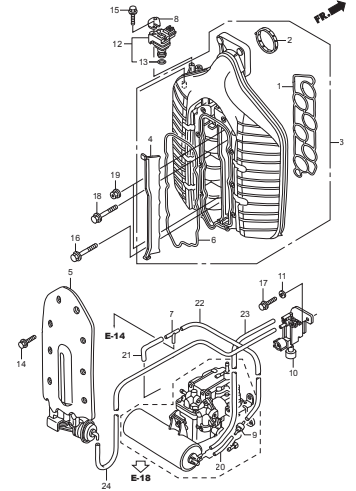

E-15 THROTTLE BODY

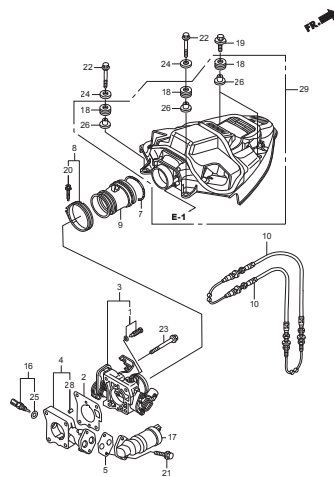

E-18 VAPOR SEPARATOR ASSY

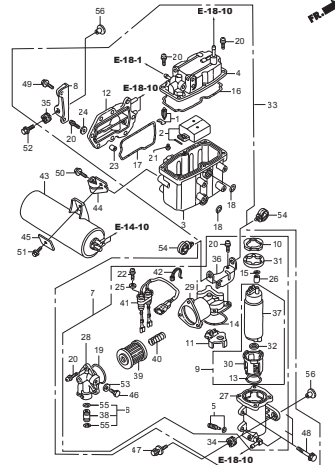

E-18-1 WATER SEPARATOR/FUEL STRAINER

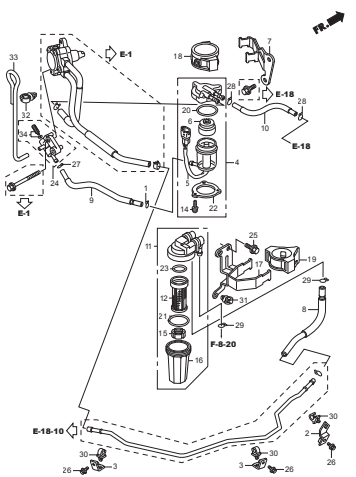

E-18-10 PIPING

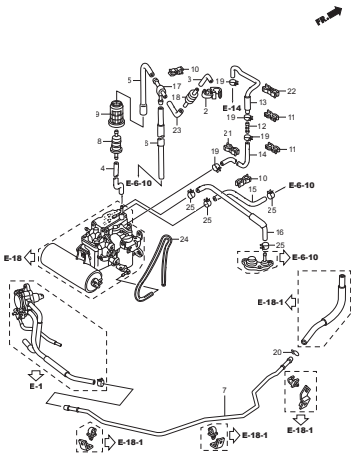

E-19 A.C.GENERATOR

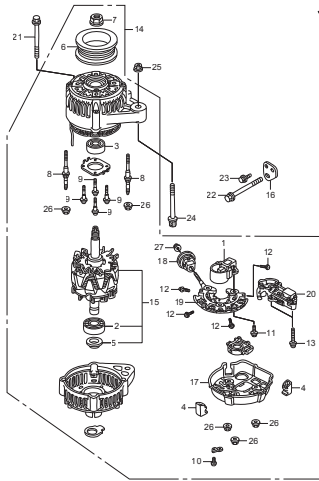

E-20 SPARK PLUG

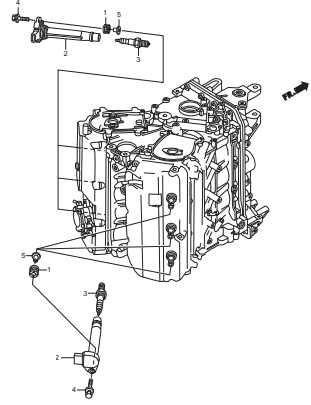

E-20-10 ELECTRONIC CONTROL UNIT

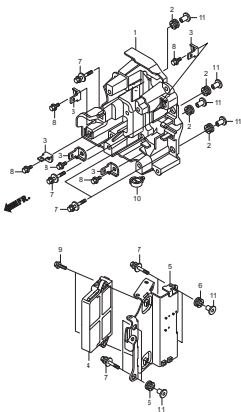

E-21 STARTER MOTOR

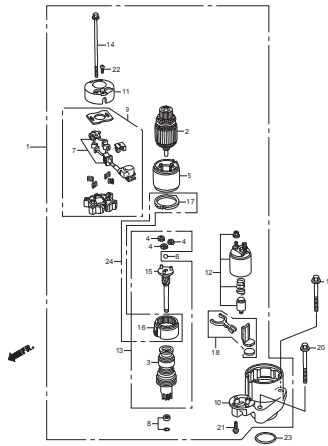

F-2 SHIFT SHAFT

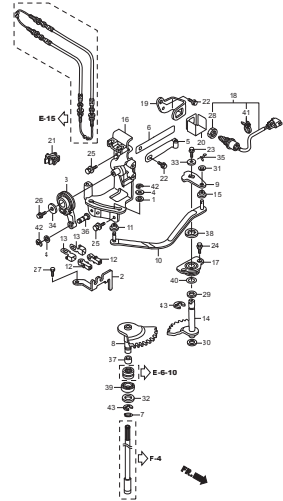

F-3 GEAR CASE

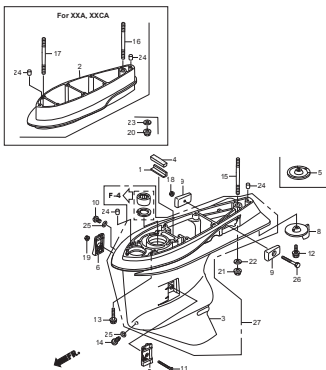

F-3-10 GEAR CASE ASSY

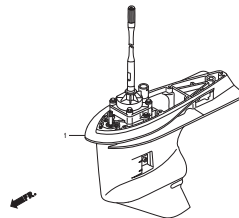

F-3-20 EXTENSION CASE

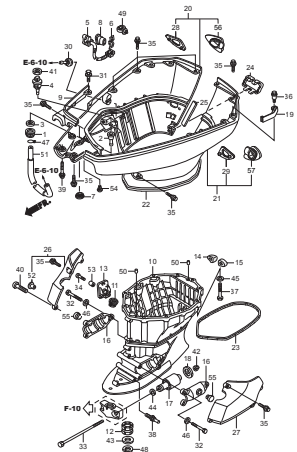

F-4 WATER PUMP/VERTICAL SHAFT

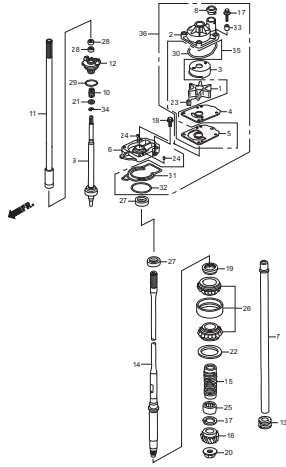

F-5 PROPELLER SHAFT

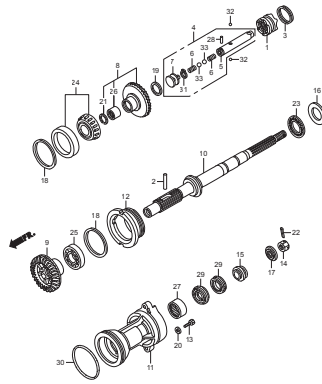

F-5-1 PROPELLER SHAFT (COUNTER ROTATION)

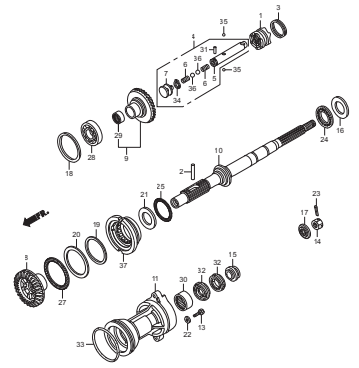

F-6 FUEL TUBE

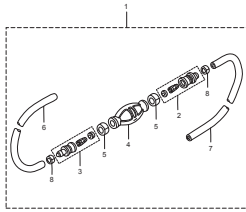

F-7 WIRE HARNESS

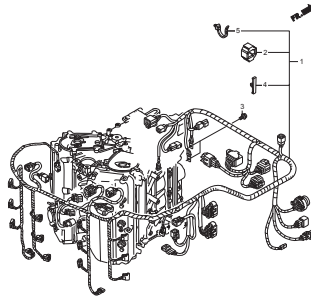

F-7-10 STARTER CABLE

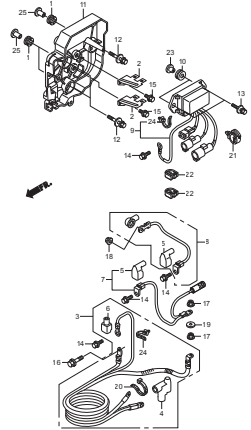

F-7-20 FUSE BOX/RELAY

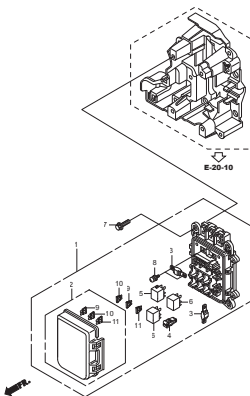

F-8 ENGINE COVER

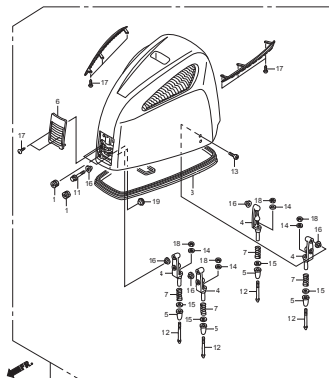

F-8-10 FR.COVER BRACKET/FR.LOCK SHAFT

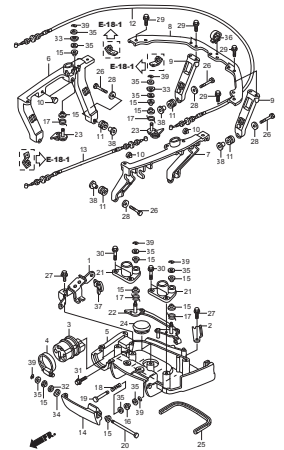

F-8-20 FUEL TUBE (2)

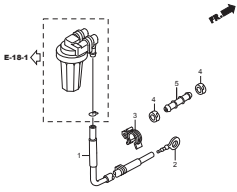

F-10 STERN BRACKET/SWIVEL CASE

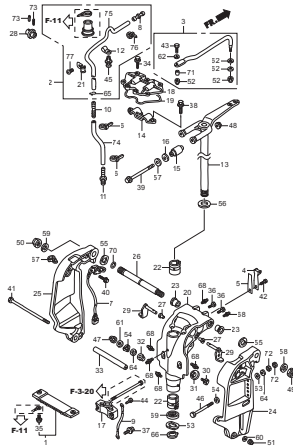

F-11 POWER TRIM-TILT

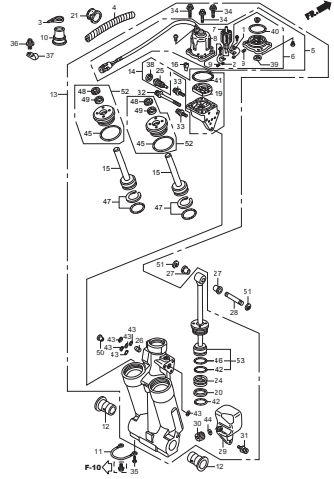

F-12 LABEL

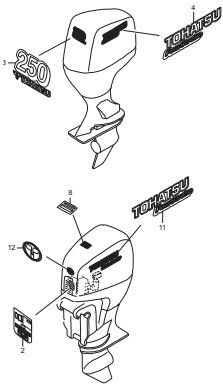

F-13 TOOL

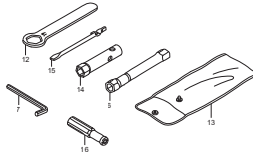

FOP-1 REMOTE CONTROL (TOP MOUNT SINGLE TYPE) (RIGHT)

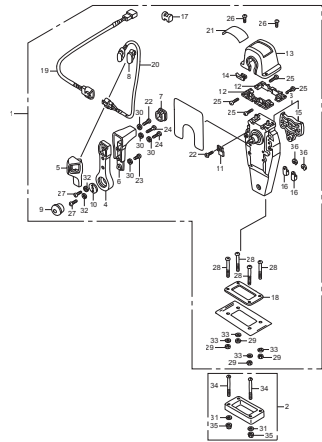

FOP-1-2 REMOTE CONTROL (TOP MOUNT DUAL TYPE) (RIGHT)

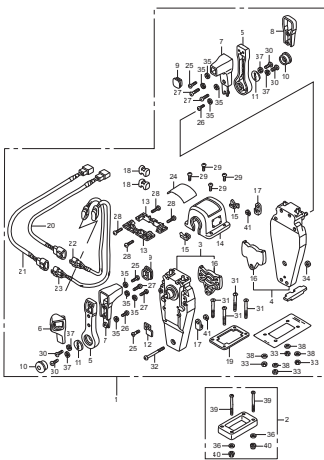

FOP-1-4 REMOTE CONTROL (FRUSH MOUNT TYPE) (RIGHT)

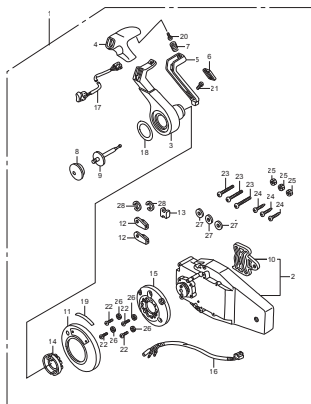

FOP-1-6 REMOTE CONTROL (HI-LEX) (HANDLE CAP = GRAY)

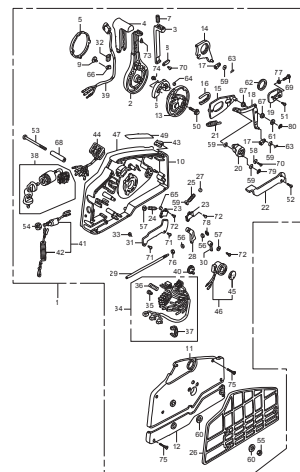

**FOP-1-7 REMOTE CONTROL
(NHK MEC) (HANDLE CAP = CHROME)**

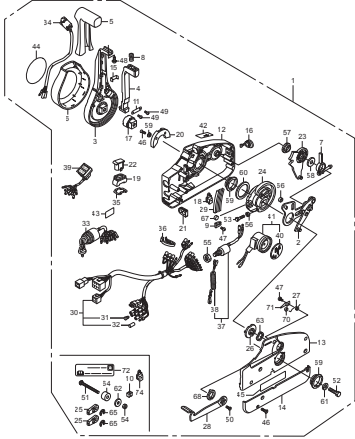

FOP-3 METER

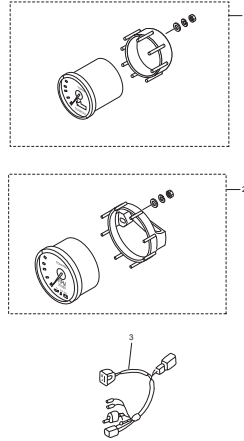

FOP-5 BOLT KIT

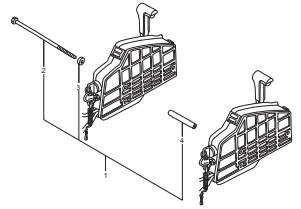

FOP-6 SWITCH PANEL KIT

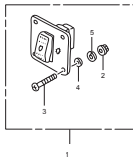

FOP-7 CONTROL PANEL (1)

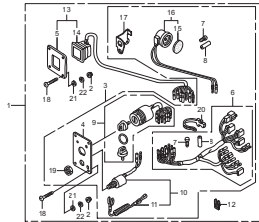

FOP-7-1 CONTROL PANEL (2)

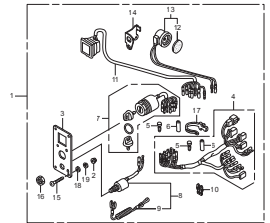

FOP-8 PROPELLER

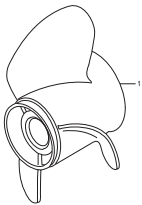

FOP-9 TRIM ADJUST PLATE SET

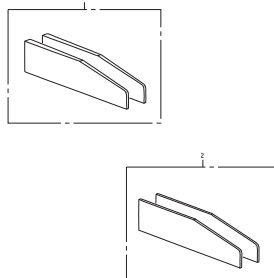

FOP-10 INTERFACE CABLE KIT

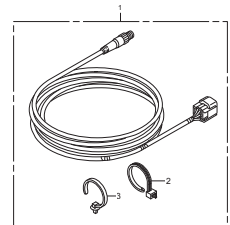

FOP-12 GEAR CASE KIT

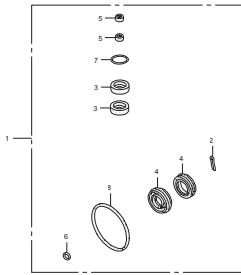

FOP-13 PANEL INTERFACE CABLE SET

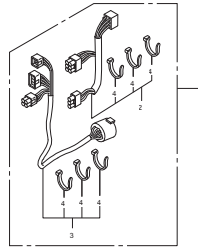

Ref.No.	Part No.	Description	Q' ty	Remarks	
			BFT250A		
E-1	1	HZY3-12310-405ZA	COVER, R. CYLINDER HEAD	1	*NH8* DARK GRAY
E-1	2	HZY3-12312-000	PACKING, HEAD COVER	2	
E-1	3	HZY3-12320-405ZA	COVER, L. CYLINDER HEAD	1	*NH8* DARK GRAY
E-1	4	HP08-12342-004	SEAL, SPARK PLUG TUBE(NOK)	6	
E-1	5	HZY3-15425-010	TUBE, OIL	2	
E-1	6	HZY3-16203-000	BRACKET, SOLENOID VALVE	1	
E-1	7	HZX2-16700-003	PUMP ASSY., FUEL	1	
E-1	8	HZX2-16870-C00	TUBE COMP., FUEL(C)	1	
E-1	9	HZY3-16895-C00	TUBE COMP. G, FUEL	1	
E-1	10	HMT2-17193-000	T-JOINT	1	
E-1	11	HZW9-32114-730	BRACKET, CLIP B	1	
E-1	12	HZY3-32129-000	BRACKET C, HARNESS CLIP	3	
E-1	13	HHE0-50310-003	CLIP A, WIRE	1	
E-1	14	HSE0-53740-953	CLIP, SENSOR HOSE	1	
E-1	15	HSD9-54316-013	CLIP, SHIFT WIRE	1	
E-1	16	HZW9-90011-000	BOLT, FLANGE, 6X14(CT200)	5	
E-1	17	HZW9-90019-000	BOLT, FLANGE, 6X35	16	
E-1	18	HZY3-90036-000	BOLT, FLANGE, 8X32	1	
E-1	19	HZW4-90126-000	BOLT, FLANGE, 8X45	1	
E-1	20	HZY3-90406-000	WASHER, PLAIN, 8MM	1	
E-1	21	HZY3-90602-020	CLAMP, TUBE(D32.5)	2	
E-1	22	HZV0-90604-000	CLIP, TUBE(B12)	4	
E-1	23	HZB7-90691-003	CLIP, HARNESS	1	
E-1	24	HKT7-91305-003	O-RING, 37X2.4(ARAI)	1	
E-1	25	HZY3-91401-A00	TUBE COMP. A, BREATHER	1	
E-1	26	HZY3-91402-020	TUBE B, BREATHER	1	
E-1	27	HZY3-91403-000	TUBE C, BREATHER	1	
E-1	28	HSK7-91566-003	CLIP D, WASHER TUBE	1	

FR. 

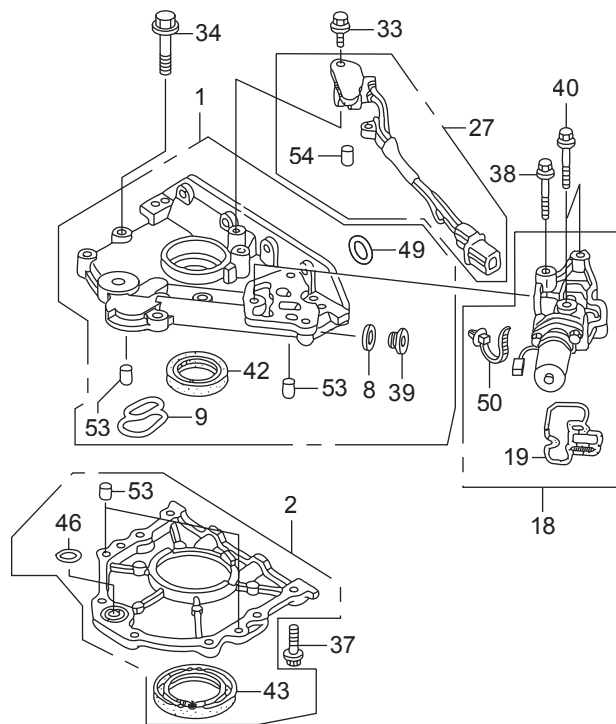
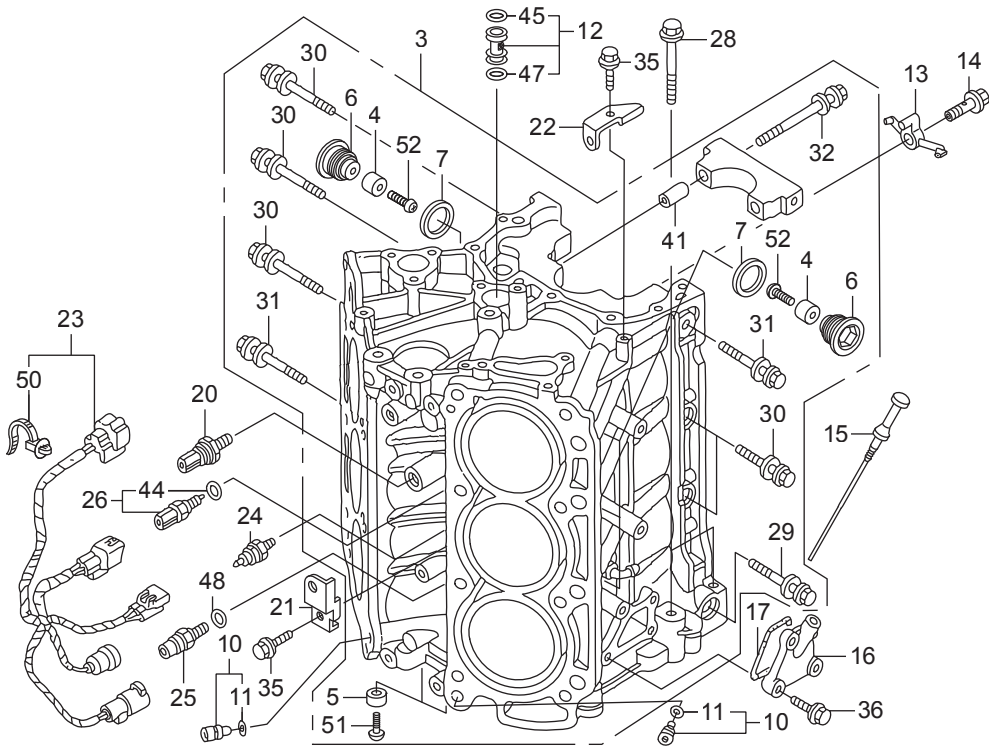

Ref.No.	Part No.	Description	Q' ty	Remarks	
			BFT250A		
E-3	1	HZY3-11200-010ZA	COVER ASSY., CRANKCASE UPPER	1	*NH8* DARK GRAY
E-3	2	HZY3-11300-C00	CASE ASSY., OIL SEAL	1	
E-3	3	HZX2-12000-405ZA	BLOCK ASSY., CYLINDER	1	*NH8* DARK GRAY
E-3	4	HZV4-12155-A00	METAL, ANODE	6	
E-3	5	HZY3-12155-000	METAL, ANODE	2	
E-3	6	HZY3-12164-000	BOLT, SEALING, 22MM	6	
E-3	7	HZY3-12171-305	WASHER, SEALING, 22MM	6	
E-3	8	HZV5-12214-000	WASHER, SEALING(22MM)	1	
E-3	9	HP8A-15115-A01	PACKING, OIL HOLE	1	
E-3	10	HP8A-15140-A00	ORIFICE ASSY., OIL CONTROL	2	
E-3	11	HP8A-15142-A00	O-RING, 8.8X2.4	2	
E-3	12	HP8A-15150-A00	JOINT ASSY., OIL PIPE	1	
E-3	13	HR70-15280-A00	BODY, OIL JET	3	
E-3	14	HRJA-15290-000	BOLT COMP., OIL JET	3	
E-3	15	HZX2-15655-000	GAUGE COMP., OIL LEVEL	1	
E-3	16	HZY3-15656-000	COVER, OIL LEVEL GAUGE	1	
E-3	17	HZY3-15657-000	PACKING, OIL LEVEL GAUGE	1	
E-3	18	HZY3-15810-003ZA	VALVE ASSY., SPOOL	1	*NH8* DARK GRAY
E-3	19	HZY3-15825-003	FILTER ASSY., SPOOL VALVE	1	
E-3	20	HRNA-30530-A01	SENSOR COMP., KNOCK	1	
E-3	21	HZW9-32114-730	BRACKET, CLIP B	1	
E-3	22	HZY3-32116-000	BRACKET B, HARNESS CLIP	1	
E-3	23	HZY3-32193-C00	CORD, SWITCH	1	
E-3	24	HZW9-35490-003	SWITCH ASSY., OIL PRESSURE	1	
E-3	25	HZY3-35490-004	SWITCH ASSY., OIL PRESSURE	1	
E-3	26	HZY3-35673-003	SENSOR ASSY., WATER TEMPERATURE	1	
E-3	27	HZY3-35700-003	SENSOR ASSY., CRANK	1	
E-3	28	HZY3-90001-000	BOLT, FLANGE, 12X95	2	
E-3	29	HZY3-90006-003	BOLT-WASHER, 10X109	1	

FR. →

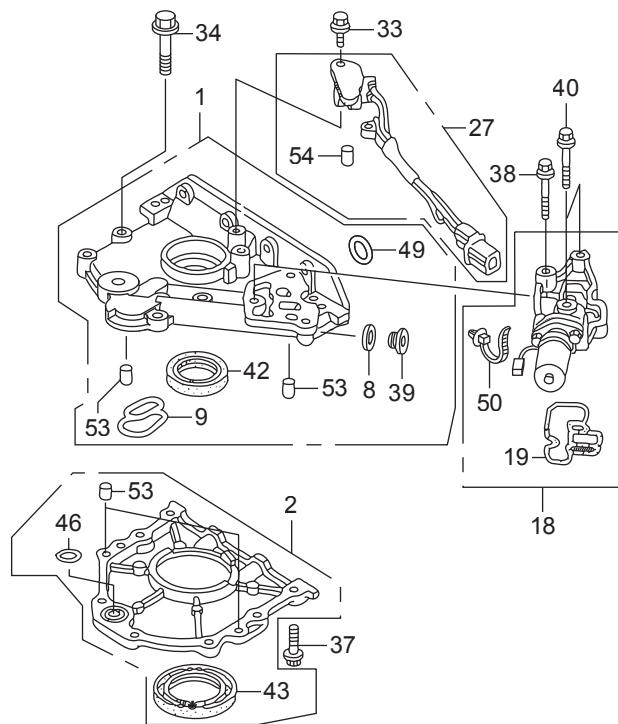
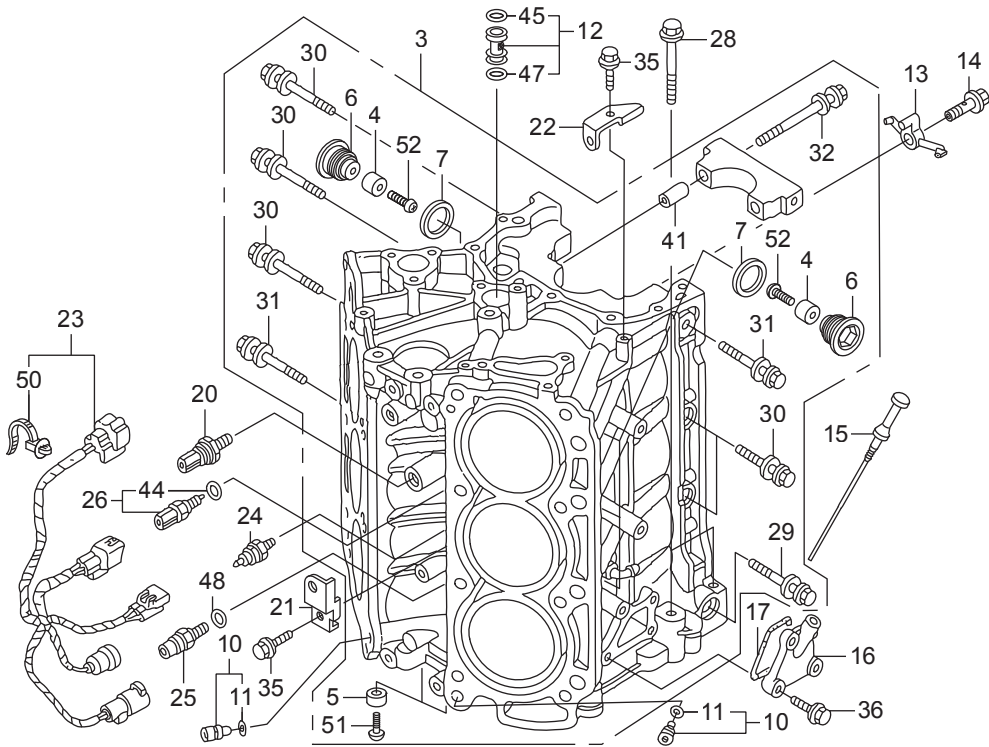

Ref.No.		Part No.	Description	Q' ty	Remarks
				BFT250A	
E-3	30	HZY3-90008-003	BOLT-WASHER, 10X60	5	
E-3	31	HZY3-90009-003	BOLT-WASHER, 10X80	2	
E-3	32	HRCA-90014-A01	BOLT-WASHER, 11X105	8	
E-3	33	HZY3-90017-000	BOLT, FLANGE, 6X16	1	
E-3	34	HZW9-90019-000	BOLT, FLANGE, 6X35	7	
E-3	35	HZY3-90021-000	BOLT, FLANGE, 6X14	2	
E-3	36	HZY3-90028-000	BOLT, FLANGE, 6X18	4	
E-3	37	HZY3-90030-000	BOLT, FLANGE, 6X22	8	
E-3	38	HZY3-90038-000	BOLT, FLANGE, 8X75	1	
E-3	39	HZV5-90081-010	BOLT, SEALING, 22MM	1	
E-3	40	HZW4-90156-000	BOLT, FLANGE, 8X50	2	
E-3	41	HPH7-90715-000	DOWEL PIN, 13X37	8	LA, XA, XCA
E-3	41	H5G0-90715-A00	DOWEL PIN, 13X37	8	XXA, XXCA
E-3	42	HZY3-91212-003	OIL SEAL, 41X66X8	1	
E-3	43	HPNA-91214-014	OIL SEAL, 80X98X10(ARAI)	1	
E-3	44	HPNA-91307-003	O-RING, 9.5X1.9	1	
E-3	45	HP8A-91308-A01	O-RING, 18.3X3.5	1	
E-3	46	HPK1-91308-003	O-RING, 26.2X2.4(NOK)	1	
E-3	47	HP8A-91309-A01	O-RING, 16.3X3.5	1	
E-3	48	HPR3-91319-003	O-RING, 13X1.5(ARAI)	1	
E-3	49	HP0X-91321-003	O-RING, 25X2.4(NOK)	1	
E-3	50	HS0A-91541-003	CLIP, HARNESS BAND(BLACK)	2	(145MM)
E-3	51	HCO-93500-05016-4J	SCREW	2	
E-3	52	HCO-93500-05020-4J	SCREW	6	
E-3	53	HCO-94301-06100	DOWEL PIN, 6X10	4	
E-3	54	HCO-94303-05080	DOWEL PIN, 5X8	1	

FR. 

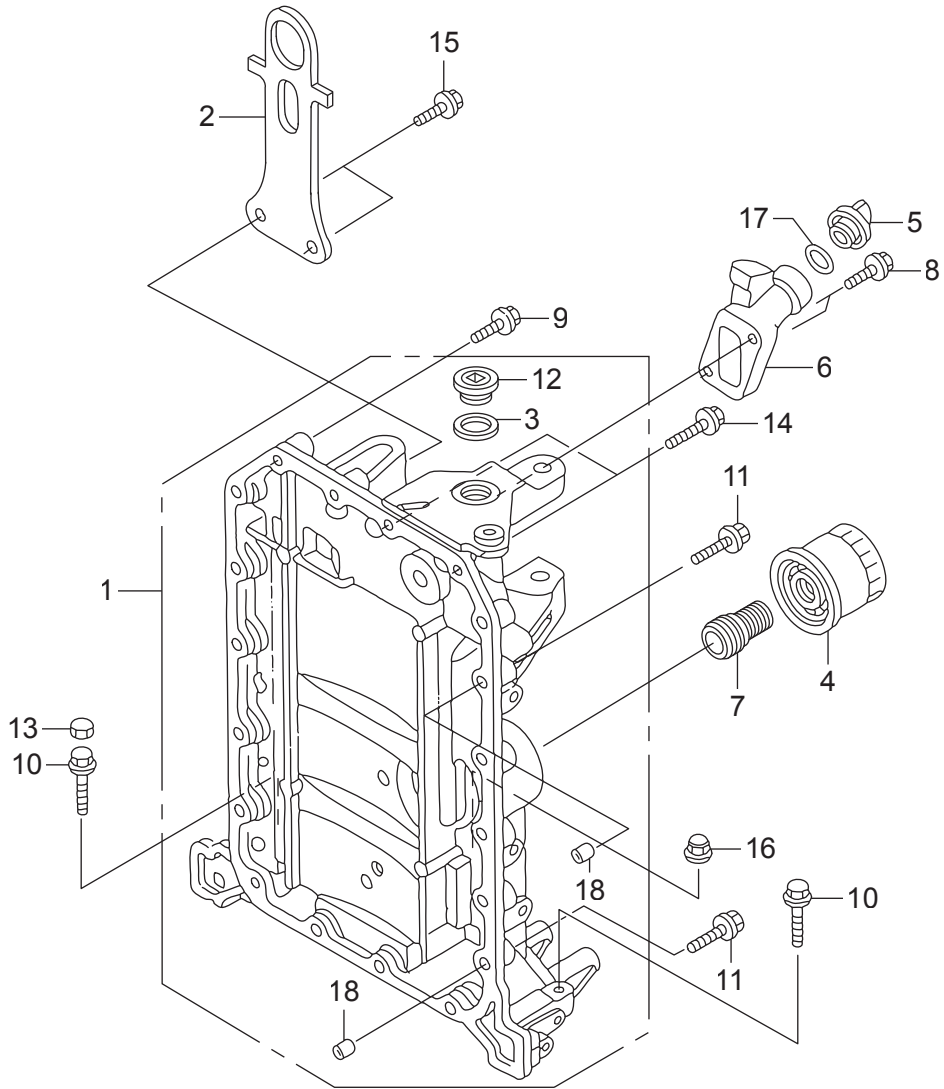

FR. 

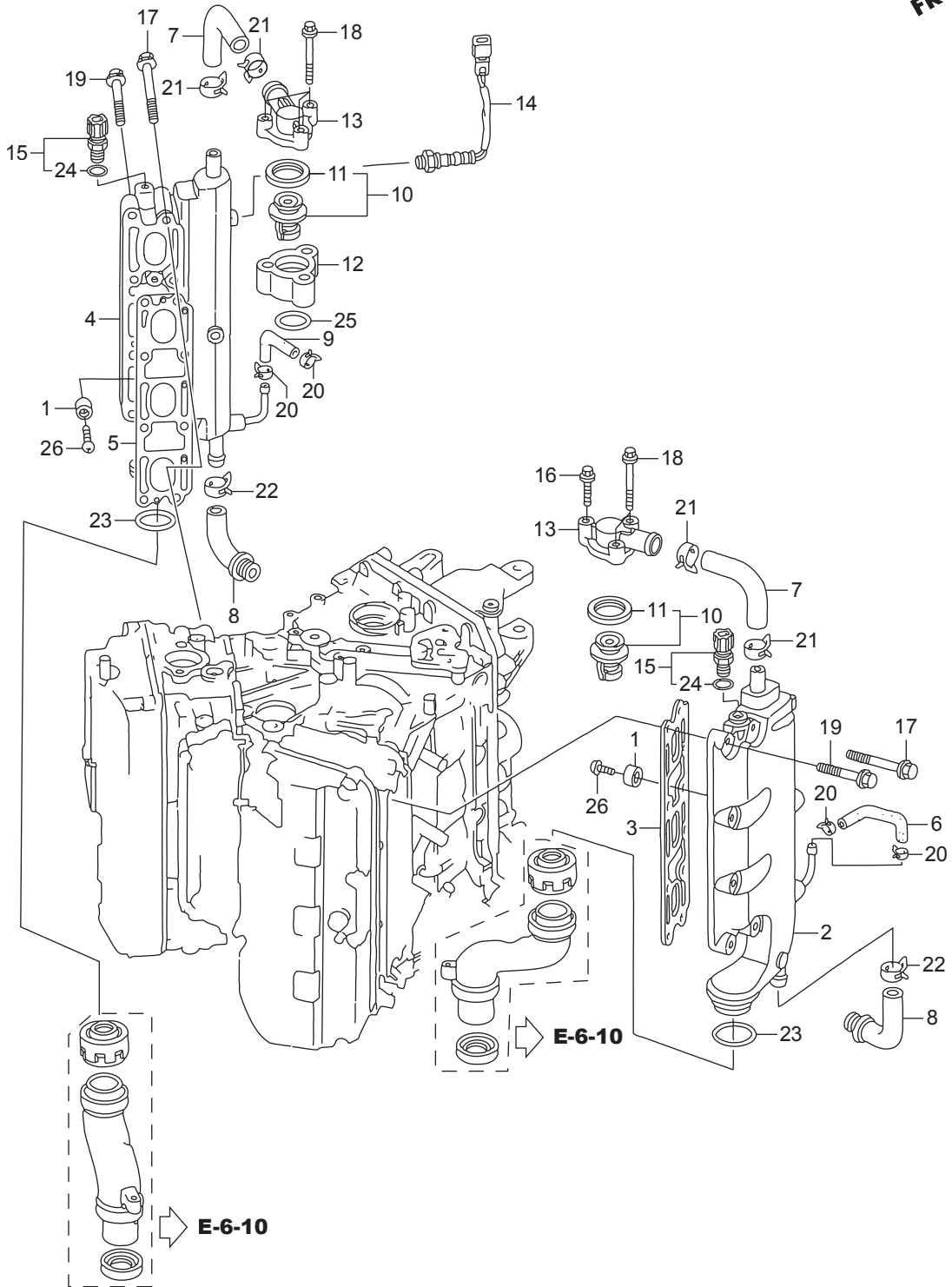

Ref.No.	Part No.	Description	Q' ty	Remarks	
			BFT250A		
E-4	1	HZV5-12155-000	METAL, ANODE	4	
E-4	2	HZY3-18110-010ZA	MANIFOLD COMP., R. EX.	1	*NH8*DARK GRAY
E-4	3	HZY3-18115-003	GASKET, R. EX. MANIFOLD	1	
E-4	4	HZY3-18120-C01ZA	MANIFOLD COMP., L. EX.	1	*NH8*DARK GRAY
E-4	5	HZY3-18125-003	GASKET, L. EX. MANIFOLD	1	
E-4	6	HZY3-19255-000	TUBE, R. WATER RETURN	1	
E-4	7	HZY3-19256-010	TUBE, WATER RELIEF	2	
E-4	8	HZY3-19257-000	TUBE, WATER	2	
E-4	9	HZY3-19261-000	TUBE, L. WATER RETURN	1	
E-4	10	HZX2-19300-003	THERMOSTAT ASSY.	2	
E-4	11	HZX2-19303-003	RUBBER, RING	2	
E-4	12	HZX2-19313-000ZA	SPACER, THERMOSTAT COVER	1	*NH8*DARK GRAY
E-4	13	HZX2-19315-000ZA	COVER, THERMOSTAT	2	*NH8*DARK GRAY
E-4	14	HZY3-35655-C01	SENSOR, OXYGEN	1	
E-4	15	HZY3-35673-003	SENSOR ASSY., WATER TEMPERATURE	2	
E-4	16	HZW9-90019-000	BOLT, FLANGE, 6X35	1	
E-4	17	HZY3-90027-000	BOLT, FLANGE, 8X60	8	
E-4	18	HZY3-90034-000	BOLT, FLANGE, 6X60	5	
E-4	19	HZW4-90155-000	BOLT, FLANGE, 8X40	8	
E-4	20	HZY3-90601-030	CLAMP, TUBE(D10.5)	4	
E-4	21	HZY3-90603-020	CLAMP, TUBE(D29)	4	
E-4	22	HZY3-90604-020	CLAMP, TUBE(D21)	2	
E-4	23	HZY3-91301-003	O-RING, 66.4X3.1	2	
E-4	24	HPNA-91307-003	O-RING, 9.5X1.9	2	
E-4	25	HSD4-91356-952	O-RING, 31.5X2.4(ARAI)	1	
E-4	26	HCO-93500-06018-4J	SCREW, PAN, 6X18	4	

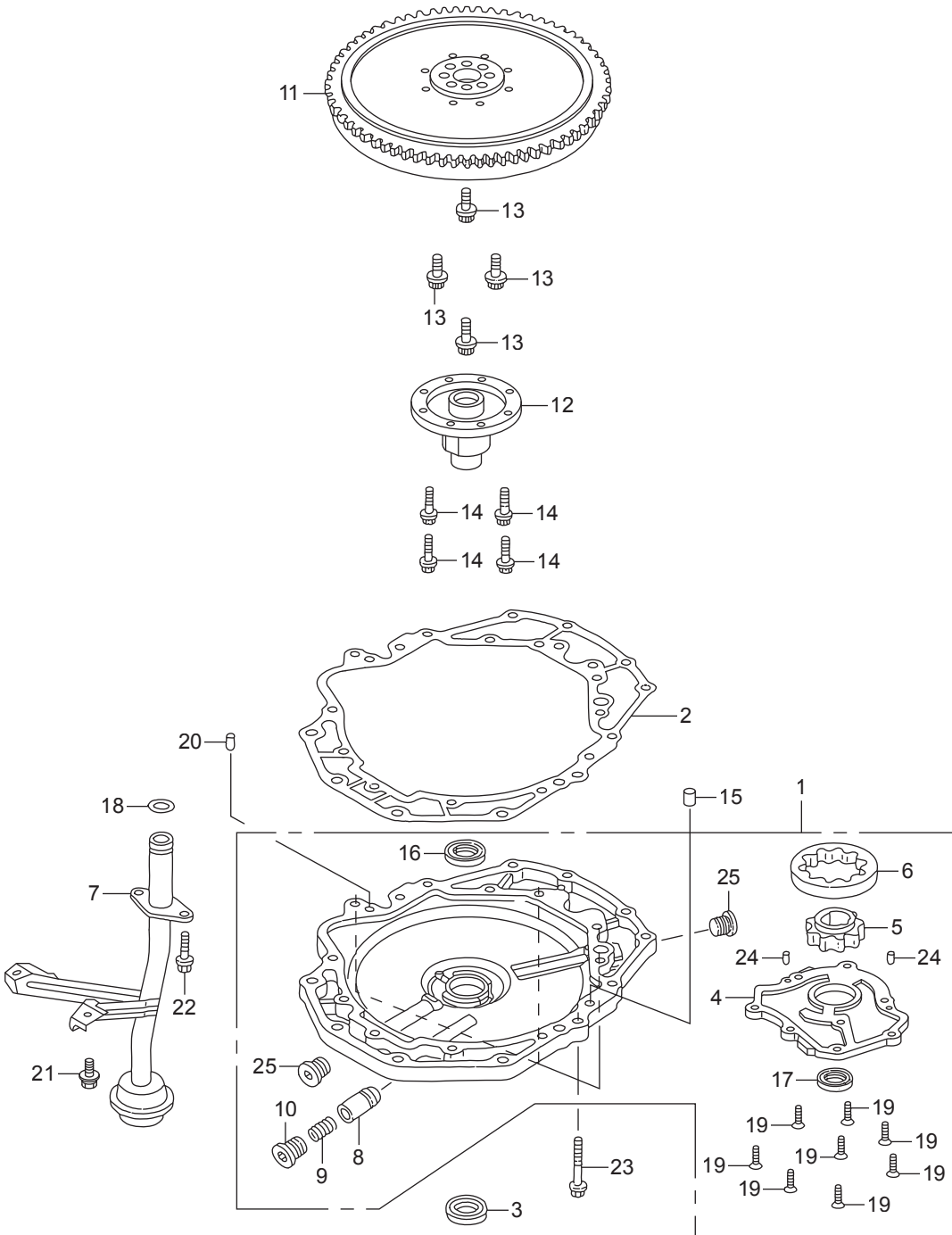

Ref.No.	Part No.	Description	Q' ty	Remarks	
			BFT250A		
E-5	1	HZY3-15100-000ZA	PUMP ASSY., OIL	1	*NH8* DARK GRAY
E-5	2	HZY3-15112-013	PACKING, OIL PUMP BODY	1	
E-5	3	HZY3-15113-000	RUBBER, OIL PUMP	1	
E-5	4	HZY3-15121-000	COVER, OIL PUMP	1	
E-5	5	HZY3-15131-405	ROTOR, OIL PUMP INNER	1	
E-5	6	HZY3-15132-405	ROTOR, OIL PUMP OUTER	1	
E-5	7	HZY3-15220-020	STRAINER COMP., OIL	1	
E-5	8	HPE0-15231-000	VALVE, RELIEF	1	
E-5	9	HPG6-15232-000	SPRING, RELIEF VALVE	1	
E-5	10	HPC6-15233-000	BOLT, SEALING, 18MM	1	
E-5	11	HZX2-31110-000ZA	FLYWHEEL COMP.	1	*TBLACK* BLACK
E-5	12	HZY3-31116-000	BOSS, FLYWHEEL	1	
E-5	13	HZX2-90001-000	BOLT, 12MM	8	
E-5	14	HZW5-90002-013	BOLT, SPECIAL, 8MM	8	
E-5	15	HPW5-90701-000	DOWEL PIN, 14X15	1	
E-5	16	HZW5-91201-003	OIL SEAL, 46X60X9	1	
E-5	17	HP01-91212-003	OIL SEAL, 31X46X7(NOK)	1	
E-5	18	HPC6-91324-000	O-RING, 20.6X2.6	1	
E-5	19	HCO-93600-06016-0A	SCREW, FLAT, 6X16	8	
E-5	20	HCO-94302-10160	PIN B, DOWEL, 10X16	1	
E-5	21	HCO-95701-06014-09	BOLT, FLANGE, 6X14	2	
E-5	22	HCO-95701-06018-09	BOLT, FLANGE, 6X18	2	
E-5	23	HCO-95701-08030-09	BOLT, FLANGE, 8X30	4	
E-5	24	HCO-96220-50080	ROLLER, 5X8	2	
E-5	25	HZV5-90081-010	BOLT, SEALING, 22MM	2	

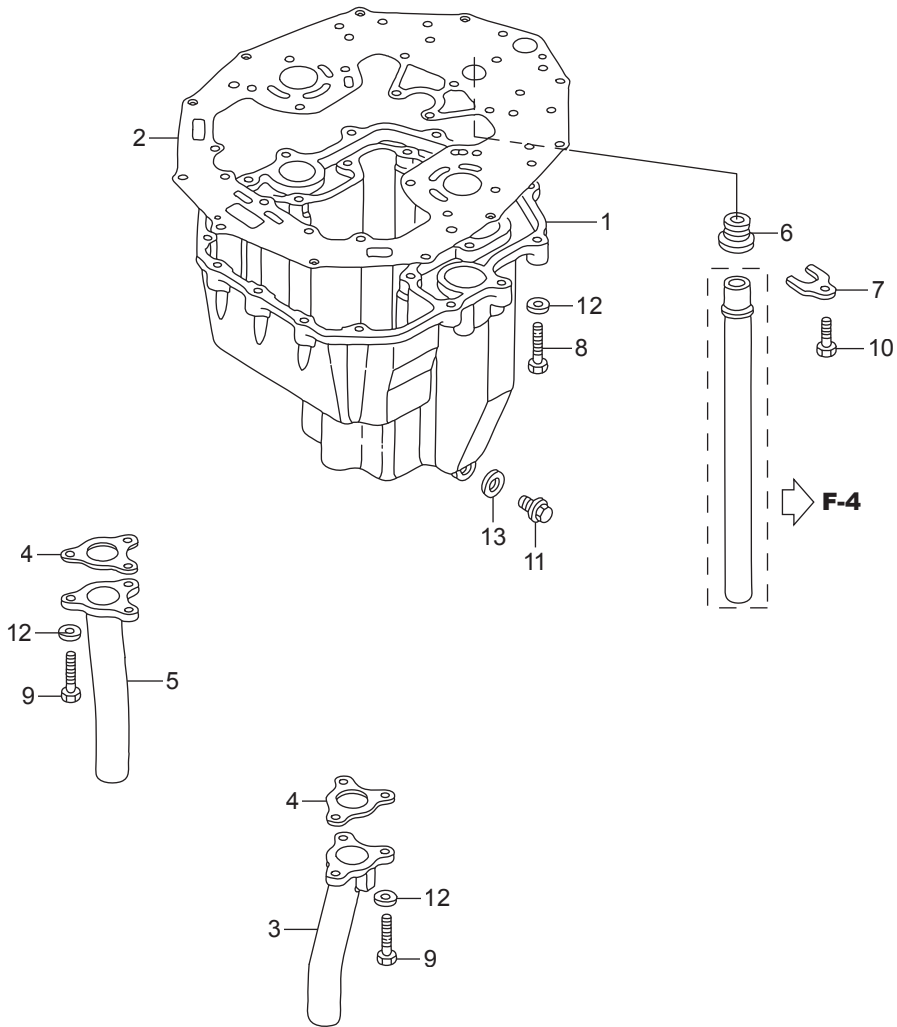

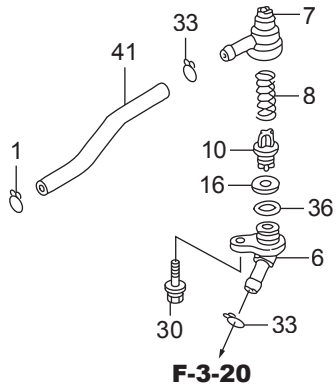

F-3-20

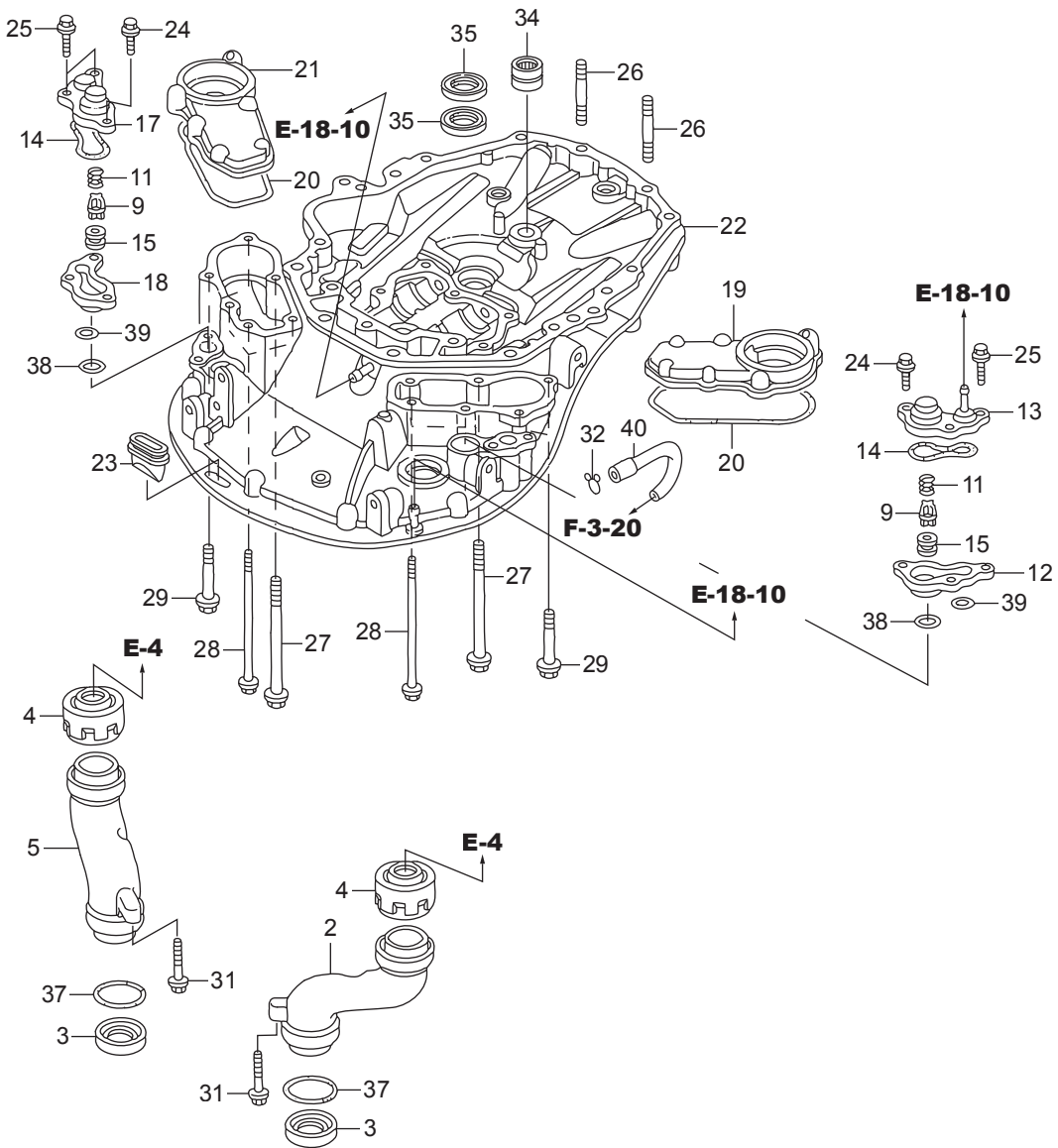

Ref.No.	Part No.	Description	Q' ty	Remarks	
			BFT250A		
E-6-10	1	HGHB-16163-610	CLIP, TUBE	1	
E-6-10	2	HZY3-18141-A00ZA	GUIDE, R. EX.	1	*TGRAY* GRAY
E-6-10	3	HZY3-18148-003	SEAL, EXHAUST GUIDE	2	
E-6-10	4	HZY3-18149-A01	SEAL B, EX. GUIDE	2	
E-6-10	5	HZY3-18151-A00ZA	GUIDE, L. EX.	1	*TGRAY* GRAY
E-6-10	6	HZY3-19277-000ZA	COVER, FLUSH VALVE	1	*NH8*DARK GRAY
E-6-10	7	HZY3-19278-000	CASE, FLUSH VALVE	1	
E-6-10	8	HZW9-19279-000	SPRING, FLUSH VALVE	1	
E-6-10	9	HZW5-19291-000	VALVE, RELIEF	2	
E-6-10	10	HZW9-19291-000	VALVE, FLASH	1	
E-6-10	11	HZW5-19292-000	SPRING, RELIEF VALVE	2	
E-6-10	12	HZY3-19294-000ZB	SPACER, R. RELIEF VALVE	1	*TGRAY* GRAY
E-6-10	13	HZY3-19295-000	COVER, R. RELIEF VALVE	1	
E-6-10	14	HZY3-19296-000	PACKING, RELIEF VALVE COVER	2	
E-6-10	15	HZW5-19297-000	PACKING, RELIEF VALVE	2	
E-6-10	16	HZW9-19297-000	PACKING, FLASH VALVE	1	
E-6-10	17	HZY3-19297-000	COVER, L. RELIEF VALVE	1	
E-6-10	18	HZY3-19298-000ZB	SPACER, L. RELIEF VALVE	1	*TGRAY* GRAY
E-6-10	19	HZY3-19361-000	COVER, R. WATER JACKET	1	
E-6-10	20	HZY3-19362-000	PACKING, WATER JACKET COVER	2	
E-6-10	21	HZY3-19366-000	COVER, L. WATER JACKET	1	
E-6-10	22	HZY3-23170-030ZA	CASE COMP., MOUNT	1	*NH8*DARK GRAY
E-6-10	23	HZY3-23173-010	RUBBER, MOUNT CASE SEAL	1	
E-6-10	24	HZY3-90030-000	BOLT, FLANGE, 6X22	2	
E-6-10	25	HZY3-90031-000	BOLT, FLANGE, 6X32	4	
E-6-10	26	HZY3-90045-000	BOLT, STUD, 10X45	2	
E-6-10	27	HZY3-90046-000	BOLT, FLANGE, 8X100	2	
E-6-10	28	HZY3-90047-000	BOLT, WASHER, 6X121	6	
E-6-10	29	HZY3-90049-000	BOLT, FLANGE, 8X30	4	

FR. 

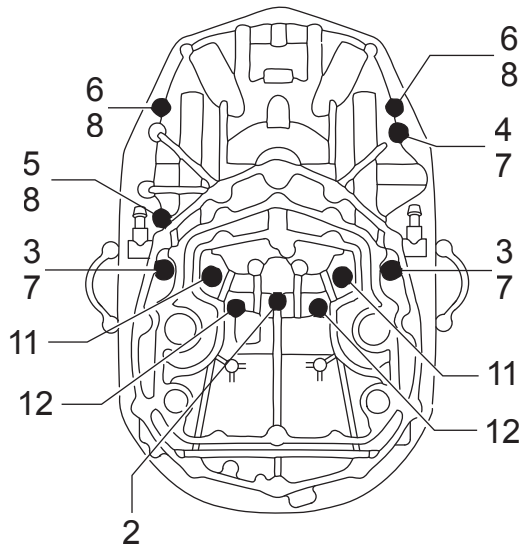
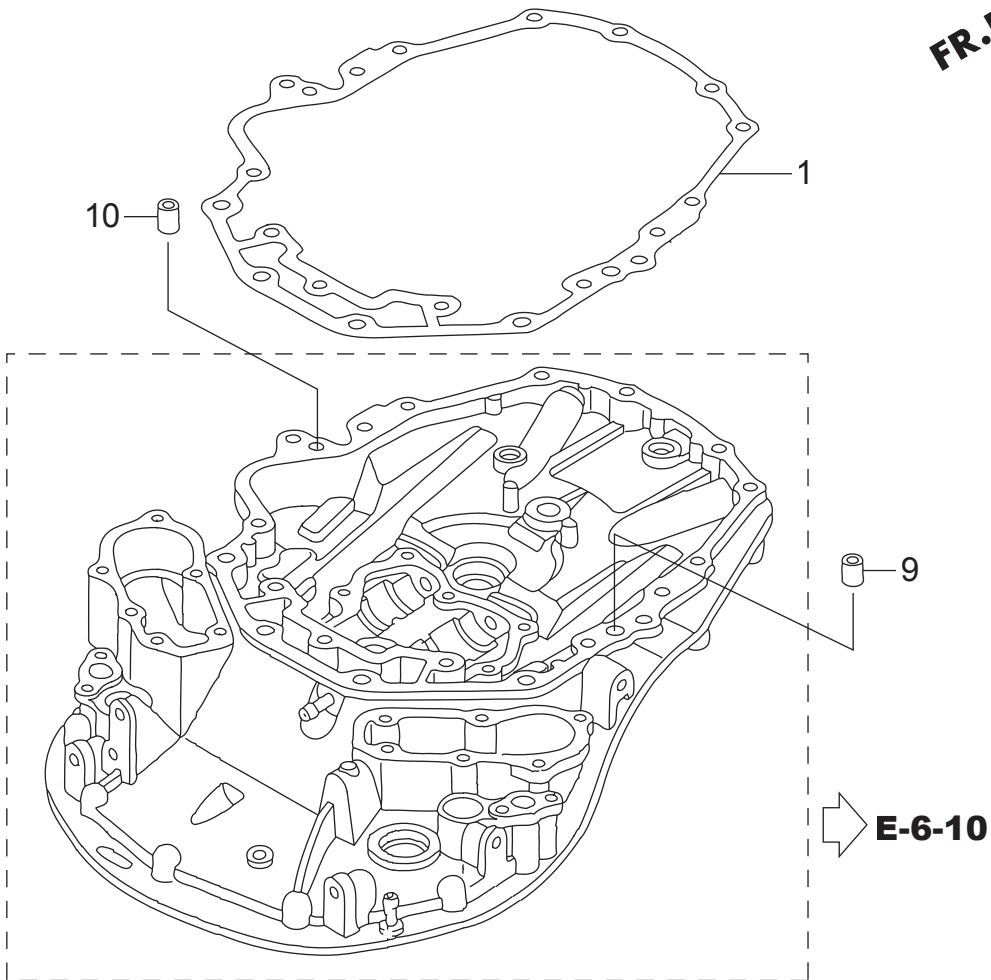

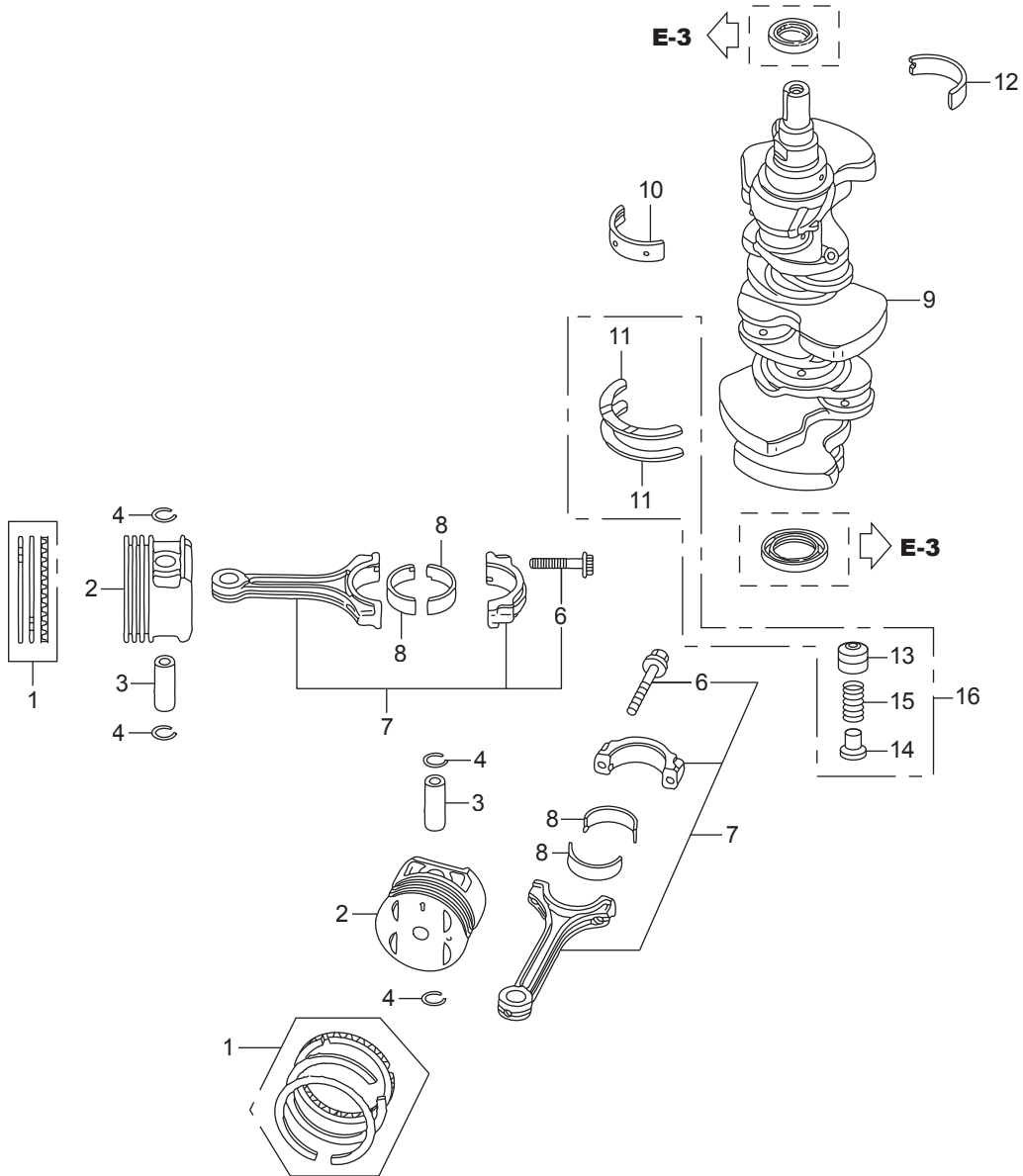

Ref.No.	Part No.	Description	Q' ty	Remarks	
			BFT250A		
E-7	1	HZX2-13010-000	RING SET, PISTON(STD.)(RIKEN)	6	
E-7	1	HZX2-13011-000	RING SET, PISTON(0.25)(RIKEN)	6	
E-7	2	HZX2-13101-000	PISTON	6	
E-7	2	HZX2-13102-000	PISTON(0.25)	6	
E-7	3	HPEA-13111-000	PIN, PISTON	6	
E-7	4	HP5A-13115-000	CLIP, PISTON PIN	12	
E-7	6	HP8A-13204-A01	BOLT, CONNECTING ROD	12	
E-7	7	HRKG-13210-000	ROD COMP., CONNECTING	6	
E-7	8	HRYE-13211-A01	BEARING A, CONNECTING ROD (BLACK)	12	(TAIHO)
E-7	8	HRYE-13212-A01	BEARING B, CONNECTING ROD (BROWN)	12	(TAIHO)
E-7	8	HRYE-13213-A01	BEARING C, CONNECTING ROD (GREEN)	12	(TAIHO)
E-7	8	HRYE-13214-A01	BEARING D, CONNECTING ROD (YELLOW)	12	(TAIHO)
E-7	8	HRYE-13215-A01	BEARING E, CONNECTING ROD (PINK)	12	(TAIHO)
E-7	9	HRKG-13310-000	CRANKSHAFT COMP.	1	
E-7	10	HZX2-13321-003	BEARING A, MAIN UPPER(BLACK)	4	(TAIHO)
E-7	10	HZX2-13322-003	BEARING B, MAIN UPPER(BROWN)	4	(TAIHO)
E-7	10	HZX2-13323-003	BEARING C, MAIN UPPER(GREEN)	4	(TAIHO)
E-7	10	HZX2-13324-003	BEARING D, MAIN UPPER(YELLOW)	4	(TAIHO)
E-7	10	HZX2-13325-003	BEARING E, MAIN UPPER(PINK)	4	(TAIHO)
E-7	10	HZX2-13326-003	BEARING F, MAIN UPPER(RED)	4	(TAIHO)
E-7	11	HZY3-13331-A04	WASHER, THRUST	2	XXA,XXCA
E-7	12	HZX2-13341-003	BEARING A, MAIN LOWER(BLACK)	4	(TAIHO)
E-7	12	HZX2-13342-003	BEARING B, MAIN LOWER(BROWN)	4	(TAIHO)
E-7	12	HZX2-13343-003	BEARING C, MAIN LOWER(GREEN)	4	(TAIHO)
E-7	12	HZX2-13344-003	BEARING D, MAIN LOWER(YELLOW)	4	(TAIHO)
E-7	12	HZX2-13345-003	BEARING E, MAIN LOWER(PINK)	4	(TAIHO)
E-7	12	HZX2-13346-003	BEARING F, MAIN LOWER(RED)	4	(TAIHO)
E-7	13	HZY3-13391-000	RETAINER, SPRING	1	XXA,XXCA
E-7	14	HZX2-13392-000	SEAT, SPRING(250)	1	XXA,XXCA

FR. 

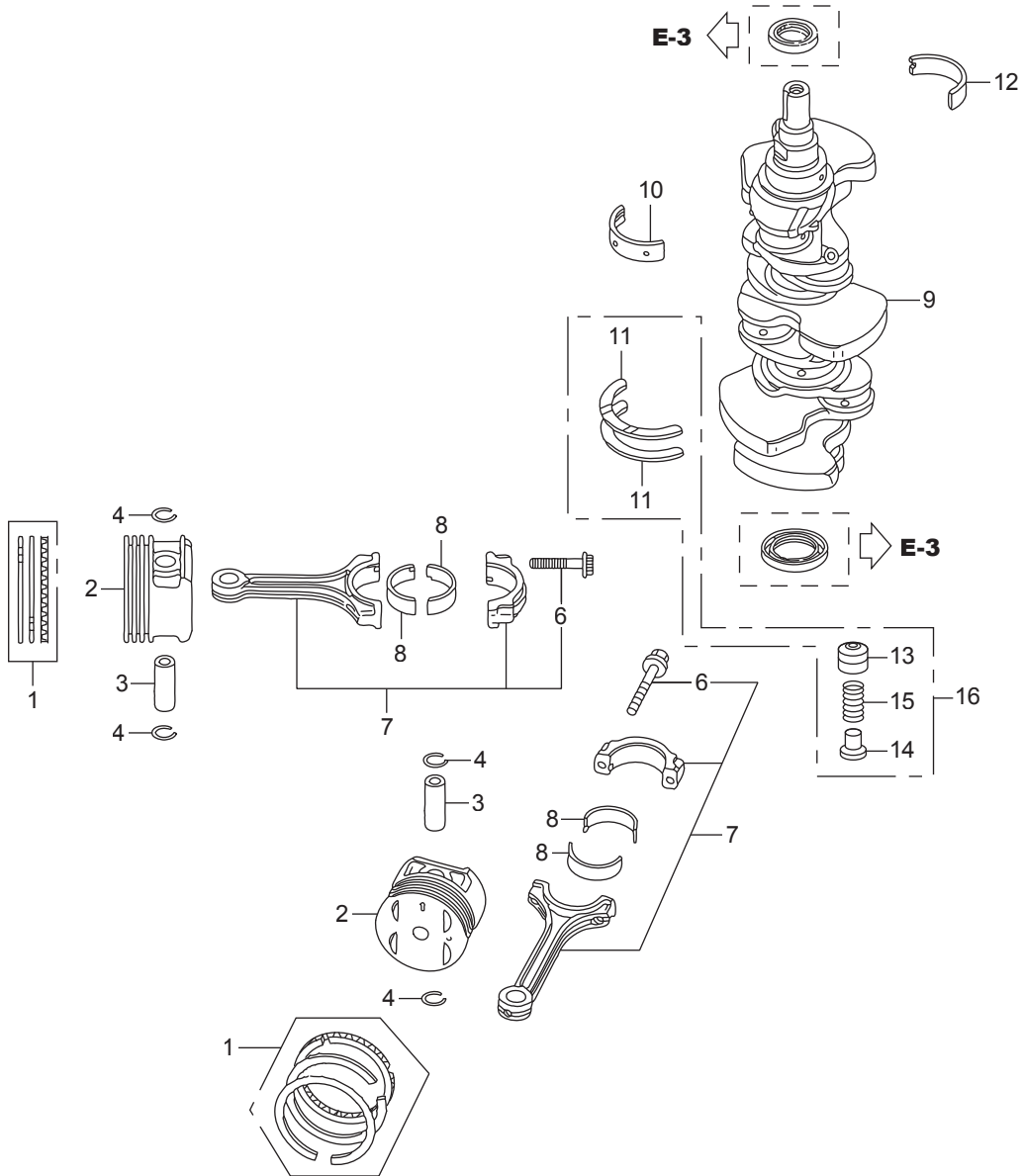

FR. 

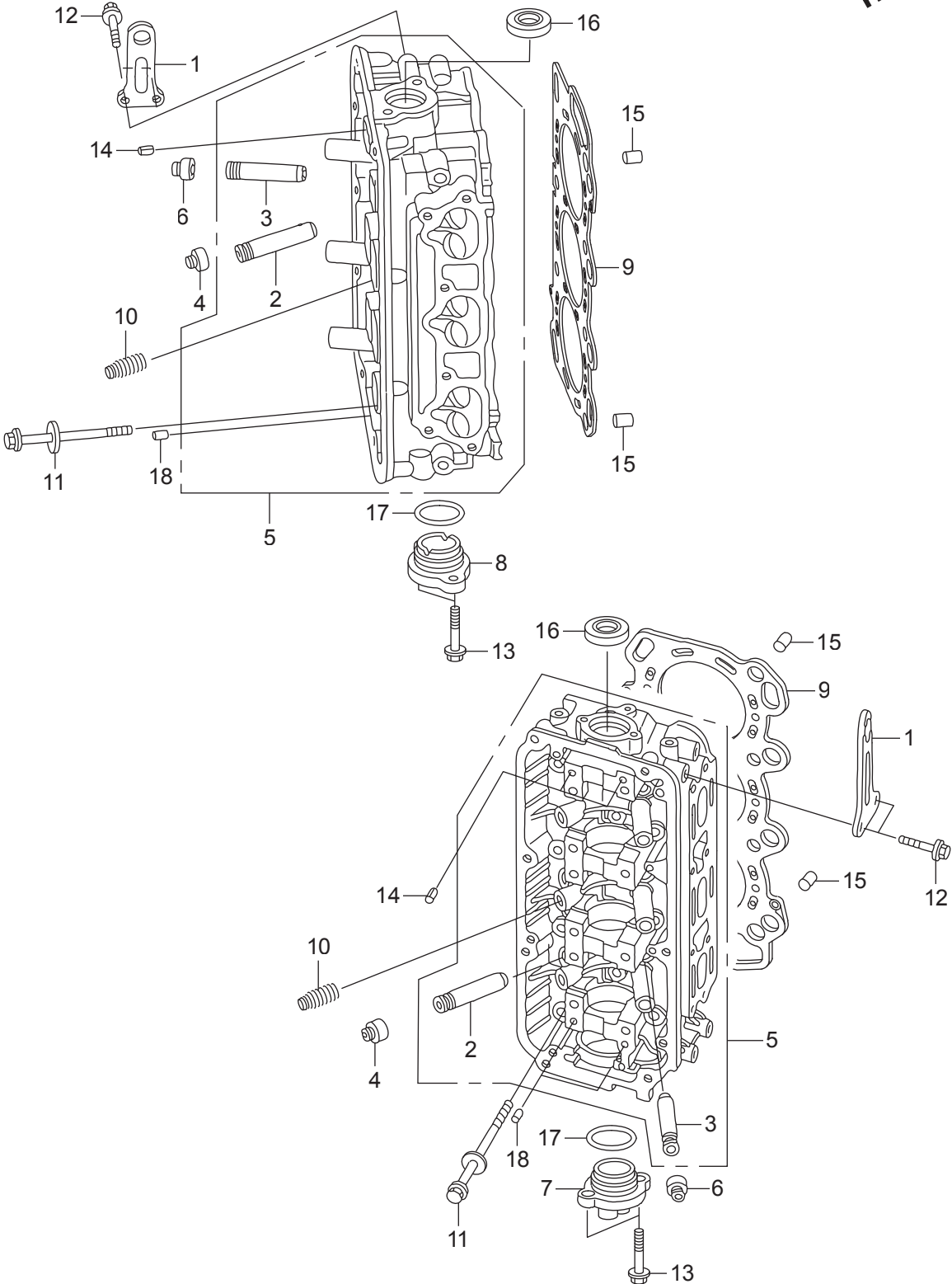

FR. 

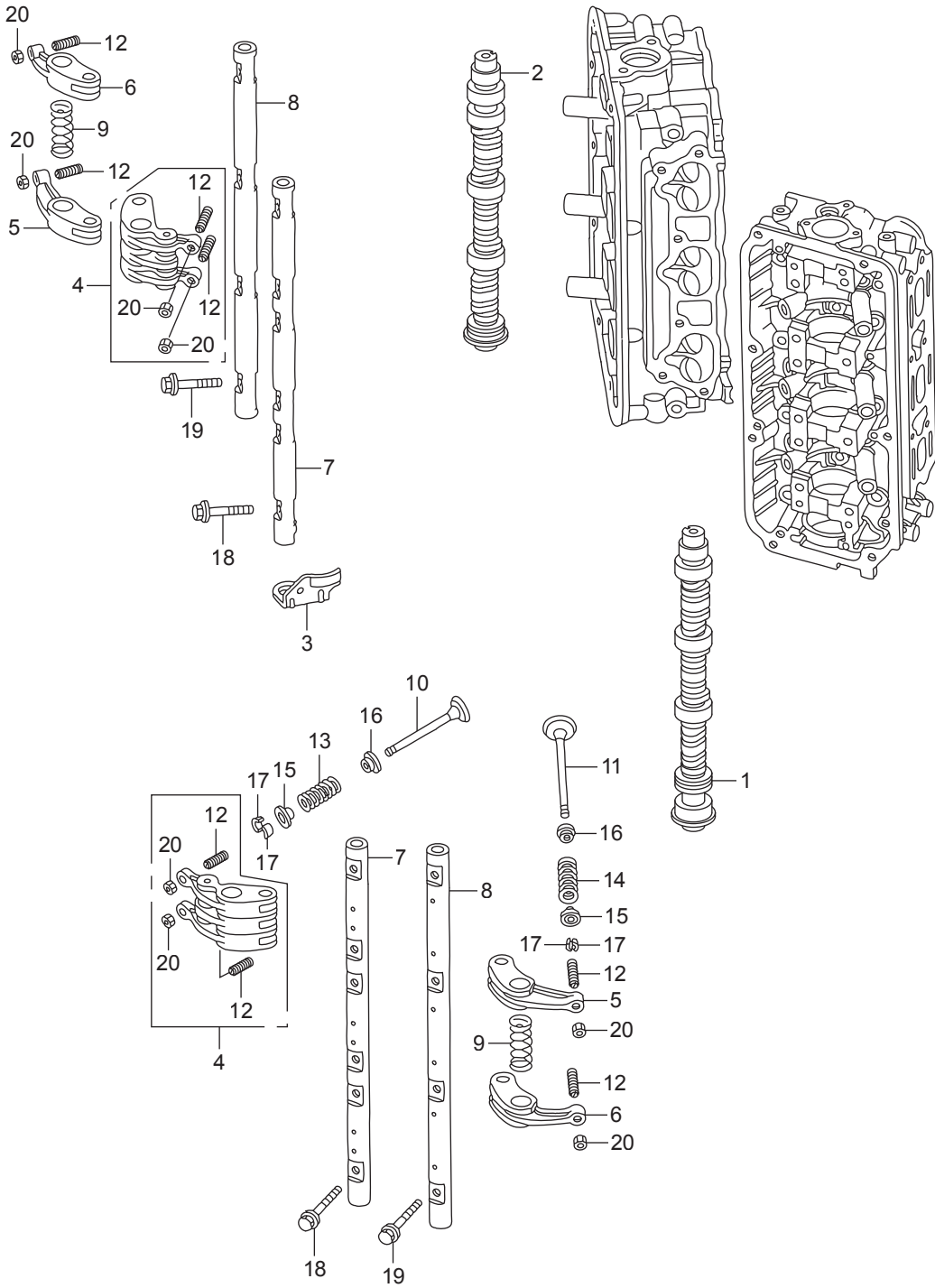

FR. →

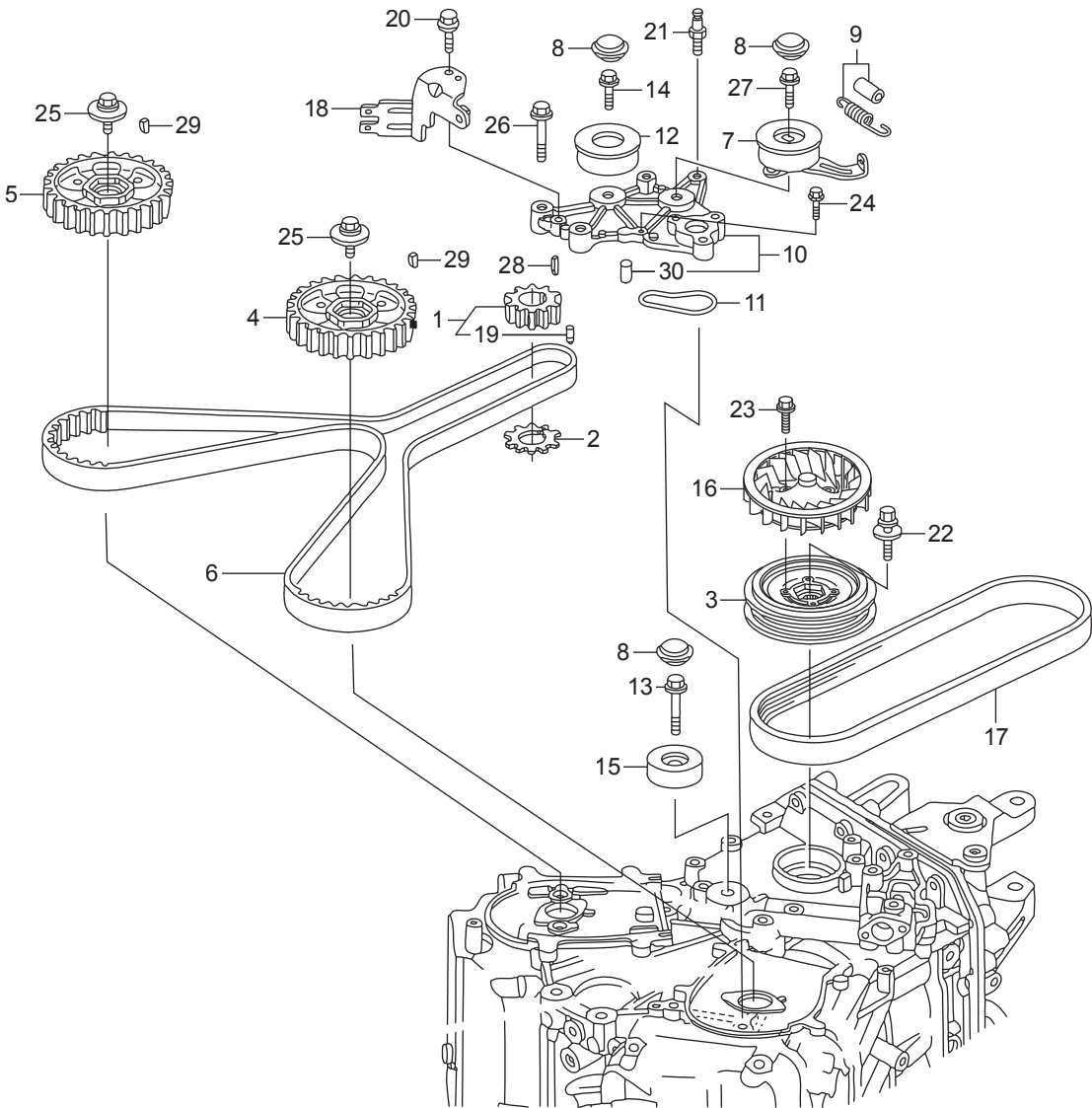

Ref.No.	Part No.	Description	Q' ty	Remarks	
			BFT250A		
E-13	1	HZY3-13621-C01	PULLEY, TIMING BELT DRIVE	1	
E-13	2	HZY3-13622-C00	PLATE, TIMING BELT GUIDE	1	
E-13	3	HZX2-13811-000	PULLEY, CRANKSHAFT	1	
E-13	4	HZY3-14261-C00	PULLEY COMP., R. TIMING BELT DRIVEN	1	
E-13	5	HZY3-14270-C00	PULLEY COMP., L. TIMING BELT DRIVEN	1	
E-13	6	HP8A-14400-A01	BELT, TIMING(197YU26 B-333)	1	
E-13	7	HZY3-14510-003	TENSIONER COMP., TIMING BELT	1	
E-13	8	HZY3-14515-000	CAP, TIMING BELT TENSIONER	3	
E-13	9	HZY3-14520-000	SPRING COMP., TIMING BELT ADJUSTING	1	
E-13	10	HZX2-14526-405ZA	BASE COMP., TIMING BELT TENSIONER	1	*NH8*DARK GRAY
E-13	11	HZY3-14529-000	O-RING, TIMING BELT TENSIONER BASE	1	
E-13	12	HZY3-14550-003	IDLER, TIMING BELT(KOYO SEIKO)	1	
E-13	13	HP8A-14551-A01	BOLT, IDLER	1	
E-13	14	HZY3-14553-003	BOLT, TIMING BELT IDLER A	1	
E-13	15	HZY3-14555-003	IDLER B, TIMING BELT	1	
E-13	16	HZX2-19511-000	FAN, COOLING	1	
E-13	17	HZY3-31638-003	BELT, A.C. GENERATOR	1	(6PK745 M-180)
E-13	18	HZY3-32111-010	BRACKET, COUPLER D	1	
E-13	19	HZV0-41122-000	PIN, VERTICAL SHAFT	1	
E-13	20	HZW9-90011-000	BOLT, FLANGE, 6X14(CT200)	1	
E-13	21	HZV5-90012-013	BOLT, TIMING BELT ADJUSTING SPRING	1	
E-13	22	HRJA-90017-003	BOLT-WASHER, 16X49	1	
E-13	23	HZY3-90017-000	BOLT, FLANGE, 6X16	4	
E-13	24	HZY3-90030-000	BOLT, FLANGE, 6X22	1	
E-13	25	HP8A-90031-A01	BOLT-WASHER, 12X35	2	
E-13	26	HZY3-90039-000	BOLT, FLANGE, 10X40	3	
E-13	27	HZY3-90040-000	BOLT, FLANGE, 10X43	1	
E-13	28	HRCA-90704-A00	KEY, 4.5X24	1	
E-13	29	HZY3-90741-000	KEY, SPECIAL	2	

FR. →

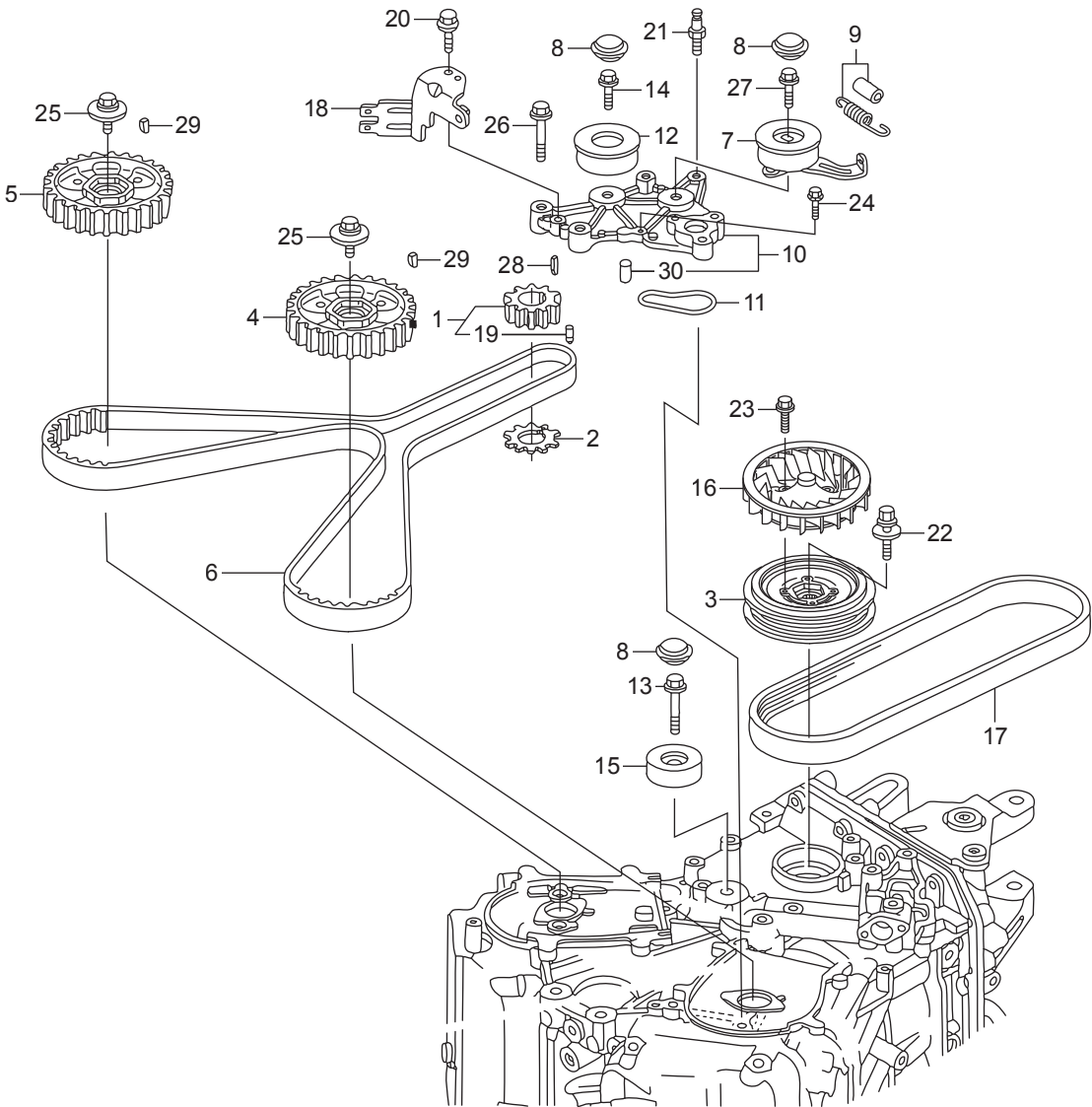

FR. 

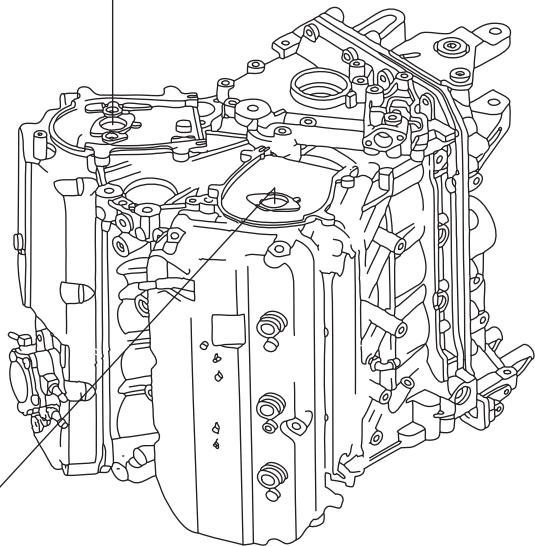
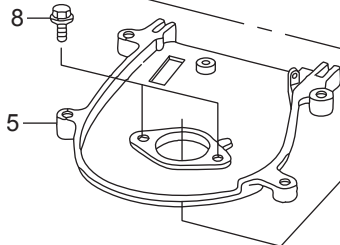
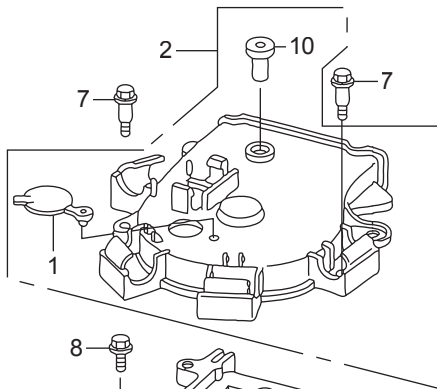
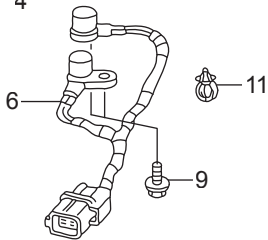
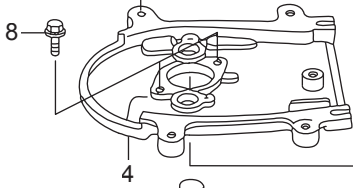
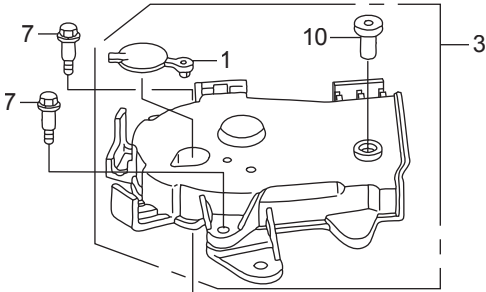

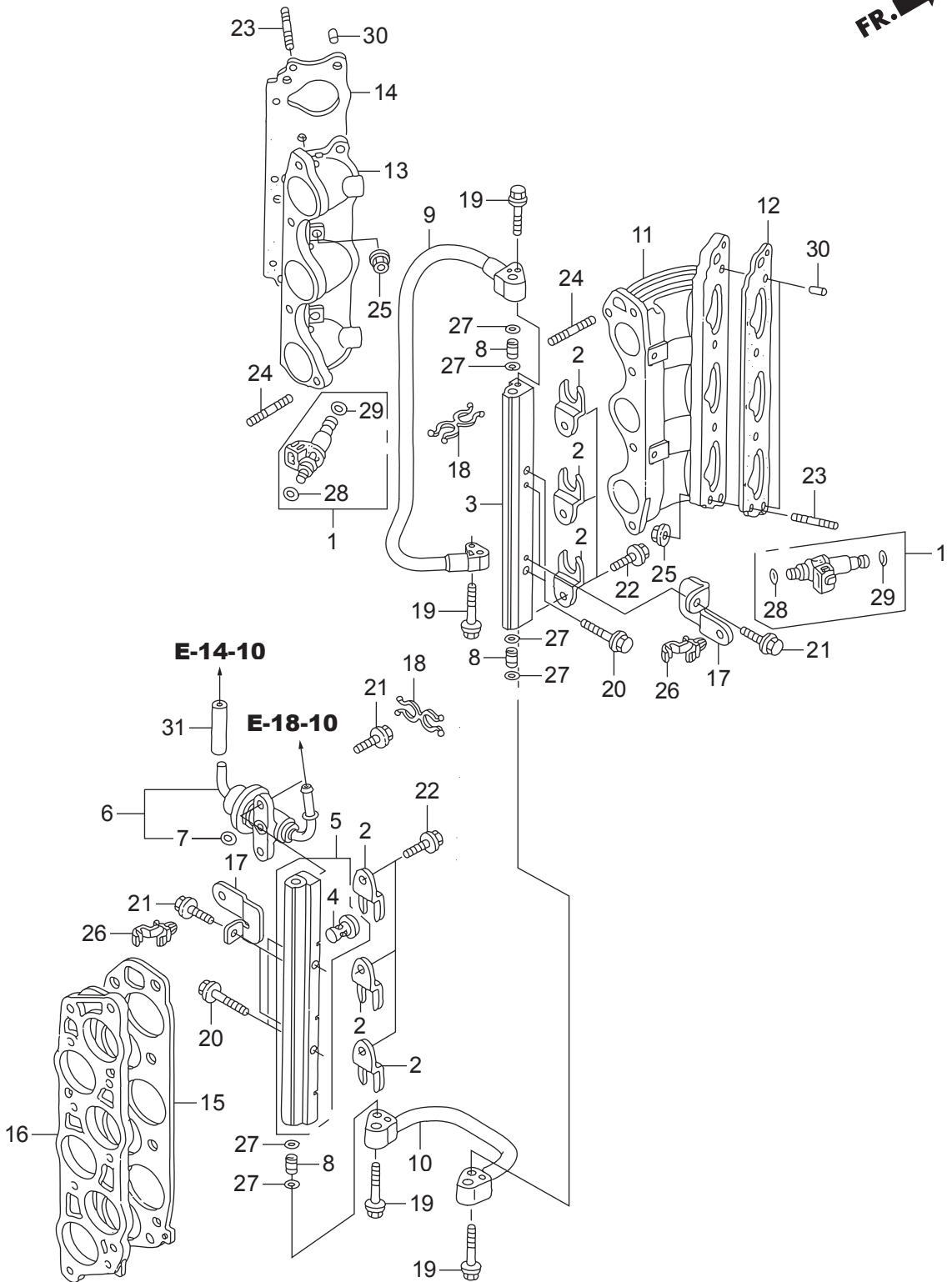

Ref.No.	Part No.	Description	Q' ty	Remarks	
			BFT250A		
E-14	1	HZY6-16450-003	INJECTOR ASSY., FUEL	6	
E-14	2	HZY3-16451-000	CLIP, INJECTOR	6	
E-14	3	HZY3-16611-A00	PIPE, R. FUEL	1	
E-14	4	HP5G-16614-003	MESH, FUEL FILTER	1	
E-14	5	HZY3-16620-A00	PIPE COMP., L. FUEL	1	
E-14	6	HZY3-16740-A01	REGULATOR ASSY., PRESSURE	1	
E-14	7	HPG7-16741-005	O-RING, PRESSURE REGULATOR	1	
E-14	8	HZY3-16752-A00	JOINT, FUEL PIPE	3	
E-14	9	HZY3-16755-003	HOSE COMP., FUEL	1	
E-14	10	HZY3-16757-003	HOSE COMP., FUEL JOINT	1	
E-14	11	HZY3-17051-A00	BASE, R. INJECTOR	1	
E-14	12	HRCA-17055-A01	GASKET, FR. INJECTOR BASE	1	
E-14	13	HZY3-17061-A00	BASE, L. INJECTOR	1	
E-14	14	HRCA-17065-A01	GASKET, RR. INJECTOR BASE	1	
E-14	15	HP8E-17105-A01	GASKET, INTAKE MANIFOLD	1	
E-14	16	HZY3-17108-000	SPACER, INTAKE MANIFOLD	1	
E-14	17	HZY3-32112-000	BRACKET, HARNESS CLIP A	4	
E-14	18	HSJ6-78419-003	CLIP D, SPEEDOMETER CABLE	2	
E-14	19	HZW9-90016-000	BOLT, FLANGE, 6X25	4	
E-14	20	HZW9-90019-000	BOLT, FLANGE, 6X35	4	
E-14	21	HZY3-90021-000	BOLT, FLANGE, 6X14	6	
E-14	22	HZY3-90042-000	BOLT, FLANGE, 6X10	6	
E-14	23	HZY3-90043-000	BOLT, STUD, 8X28	8	
E-14	24	HZY3-90044-000	BOLT, STUD, 8X45	2	
E-14	25	HZY3-90205-000	NUT, FLANGE, 8MM	8	
E-14	26	HSB2-90650-003	CLIP, WIRE HARNESS, 10MM	4	
E-14	27	HMJ0-91301-003	O-RING, 7.8X1.9(ARAI)	6	
E-14	28	HPLC-91301-000	O-RING, 7.47X3.6	6	LA,XA,XCA
E-14	29	HPNA-91302-003	O-RING, 7.45X3.61(NOK)	6	LA,XA,XCA

Ref.No.	Part No.	Description	Q' ty	Remarks	
			BFT250A		
E-14-10	1	HZY3-17105-004	GASKET, INTAKE MANIFOLD	1	
E-14-10	2	HZY3-17109-004	PACKING, THROTTLE BODY	1	
E-14-10	3	HZY3-17110-003	MANIFOLD COMP., INTAKE	1	
E-14-10	4	HZY3-17113-003	PLATE, INTAKE MANIFOLD CENTER	1	
E-14-10	5	HZY3-17130-003ZA	COVER COMP., INTAKE MANIFOLD	1	*NH8*DARK GRAY
E-14-10	6	HZY3-17138-004	PACKING, INTAKE MANIFOLD UP COVER	1	
E-14-10	7	HMG9-17201-000	JOINT A, VACUUM TUBE	1	
E-14-10	8	HZY3-32128-000	BRACKET, SENSOR CORD	1	
E-14-10	9	HPM4-36145-004	VALVE, CHECK	1	
E-14-10	10	HZY3-36163-003	VALVE ASSY., AIR BYPASS	1	
E-14-10	11	HP8D-36165-J00	WASHER, CONICAL SPRING(5)	1	
E-14-10	12	HRNA-37830-A01	SENSOR ASSY., MAP	1	
E-14-10	13	HPGK-37835-A01	O-RING	1	
E-14-10	14	HZY3-90023-000	BOLT, FLANGE, 6X22	10	
E-14-10	15	HZY3-90029-000	BOLT-WASHER, 5X18	1	
E-14-10	16	HZY3-90031-000	BOLT, FLANGE, 6X32	1	
E-14-10	17	HZY3-90058-000	BOLT, FLANGE, 5X10	1	
E-14-10	18	HZW4-90156-000	BOLT, FLANGE, 8X50	7	
E-14-10	19	HZY3-90205-000	NUT, FLANGE, 8MM	2	
E-14-10	20	HCO-95001-35040-40	TUBE, FUEL, 3.5X40	1	(HC-95001-35001-60M)
E-14-10	21	HCO-95001-35130-40	TUBE, FUEL, 3.5X130	1	(HC-95001-35001-60M)
E-14-10	22	HCO-95001-35540-40	TUBE, FUEL, 3.5X540	1	(HC-95001-35001-60M)
E-14-10	23	HCO-95001-35590-60	TUBE, FUEL, 3.5X590	1	(HC-95001-35001-60M)
E-14-10	24	HCO-95001-35600-40	TUBE, FUEL, 3.5X600	1	(HC-95001-35001-60M)

FR. 

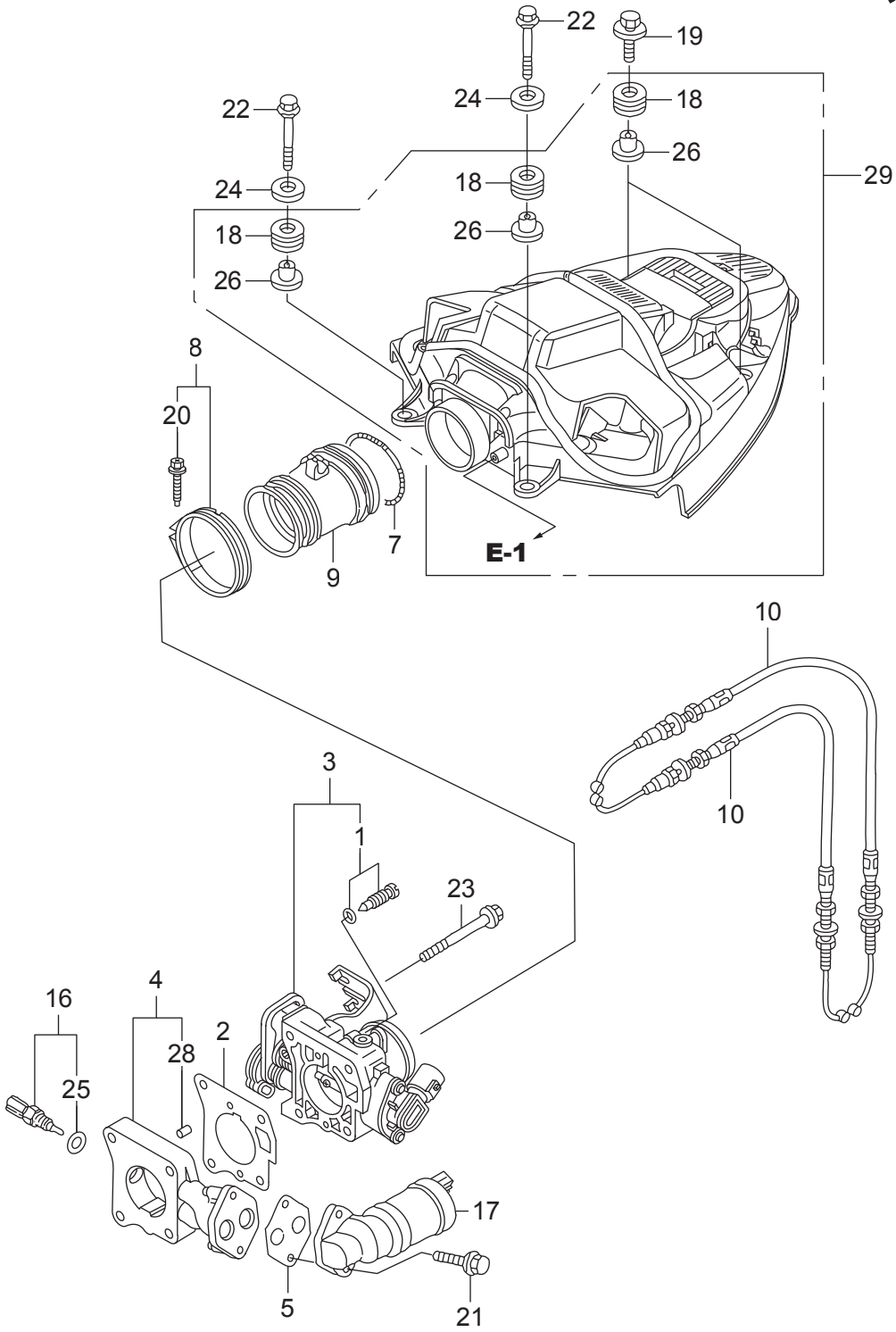

Ref.No.	Part No.	Description	Q' ty	Remarks	
			BFT250A		
E-15	1	HZY3-16016-003	SCREW SET	1	
E-15	2	HZY3-16176-000	GASKET, THROTTLE BODY	1	
E-15	3	HZY3-16400-A01	THROTTLE BODY ASSY.	1	
E-15	4	HZX2-16404-000	SPACER, THROTTLE BODY	1	
E-15	5	HZY3-16405-000	GASKET, EAC VALVE	1	
E-15	7	HPY3-17249-000	SPRING, AIR FLOW TUBE	1	
E-15	8	HZY9-17315-000	BAND, AIR FLOW	1	
E-15	9	HZX2-17374-000	GROMMET, SILENCER	1	
E-15	10	HZY3-17910-013	CABLE COMP., THROTTLE	2	
E-15	16	HZW5-35665-003	SENSOR ASSY., AIR TEMP	1	
E-15	17	HZY3-36550-003	VALVE ASSY., EAC	1	
E-15	18	HZV5-40102-000	GROMMET, UNDER CASE	4	
E-15	19	HZW1-90013-000	BOLT-WASHER, 6X25	2	
E-15	20	HZY9-90017-000	BOLT-WASHER, 5X30	1	
E-15	21	HZY3-90030-000	BOLT, FLANGE, 6X22	2	
E-15	22	HZY3-90034-000	BOLT, FLANGE, 6X60	2	
E-15	23	HZY3-90037-000	BOLT, FLANGE, 8X65	4	
E-15	24	HZY3-90508-000	WASHER, PLAIN, 6MM	2	
E-15	25	HP0A-91303-A02	O-RING	1	
E-15	26	HZV5-91553-010	COLLAR, C.D.I. UNIT CASE	4	
E-15	28	HCO-94301-06100	DOWEL PIN, 6X10	2	
E-15	29	HZX2-19540-010	COVER ASSY., COOLING FAN	1	

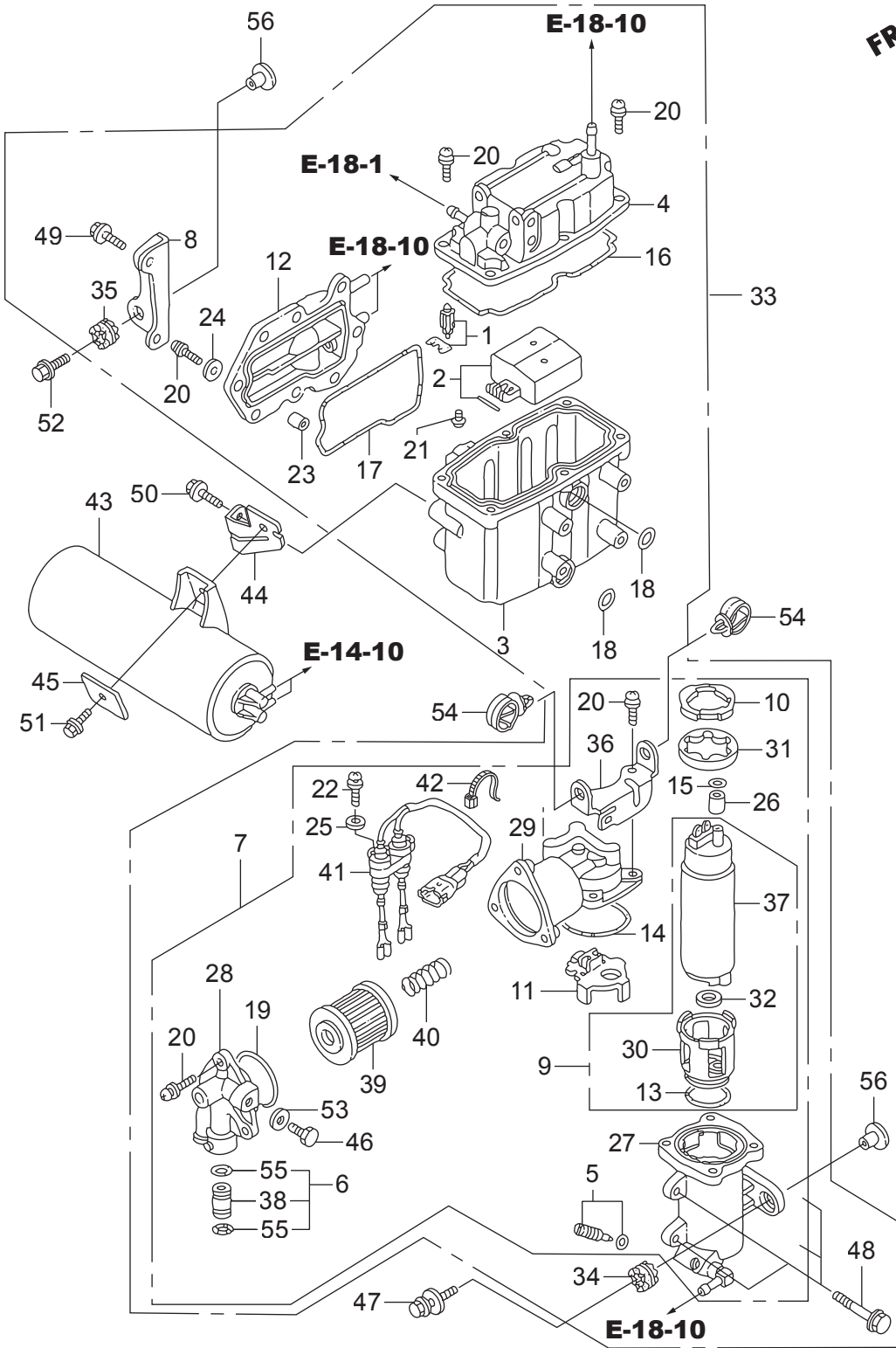

Ref.No.	Part No.	Description	Q' ty	Remarks	
			BFT250A		
E-18	1	HZY3-16011-A01	VALVE SET, FLOAT	1	
E-18	2	HZY3-16013-000	FLOAT SET	1	
E-18	3	HZY3-16015-000	BODY	1	
E-18	4	HZX2-16020-003	COVER COMP.	1	
E-18	5	HZY3-16024-000	SCREW SET, DRAIN	1	
E-18	6	HZY3-16026-000	JOINT SET	1	
E-18	7	HZX2-16030-003	PUMP UNIT SET A, FUEL	1	
E-18	8	HZY3-16031-010	STAY, PLATE	1	
E-18	9	HZY3-16036-003	PUMP UNIT SET B, FUEL	1	
E-18	10	HZY3-16041-000	PLATE	1	
E-18	11	HZY3-16042-000	HOLDER	1	
E-18	12	HZY3-16061-000	COVER, WATER JACKET	1	
E-18	13	HZY3-16072-000	O-RING	1	
E-18	14	HZY3-16073-000	O-RING	1	
E-18	15	HZY3-16074-000	O-RING	1	
E-18	16	HZY3-16075-000	O-RING	1	
E-18	17	HZY3-16076-000	O-RING	1	
E-18	18	HZY3-16077-000	O-RING	2	
E-18	19	HZY3-16078-000	O-RING	1	
E-18	20	HZW5-16081-010	SCREW-WASHER	21	
E-18	21	HZY3-16082-000	SCREW, PAN	2	
E-18	22	HZY3-16083-000	SCREW, WASHER	1	
E-18	23	HZW5-16086-000	COLLAR, SET	8	
E-18	24	HZW5-16087-000	WASHER, PLAIN	8	
E-18	25	HZY3-16087-000	WASHER, PLAIN	1	
E-18	26	HZY3-16088-000	COLLAR	1	
E-18	27	HZX2-16701-003	CASE COMP., PUMP	1	
E-18	28	HZY3-16708-000	COVER, PUMP	1	
E-18	29	HZW5-16715-023	COVER, PUMP(A)	1	

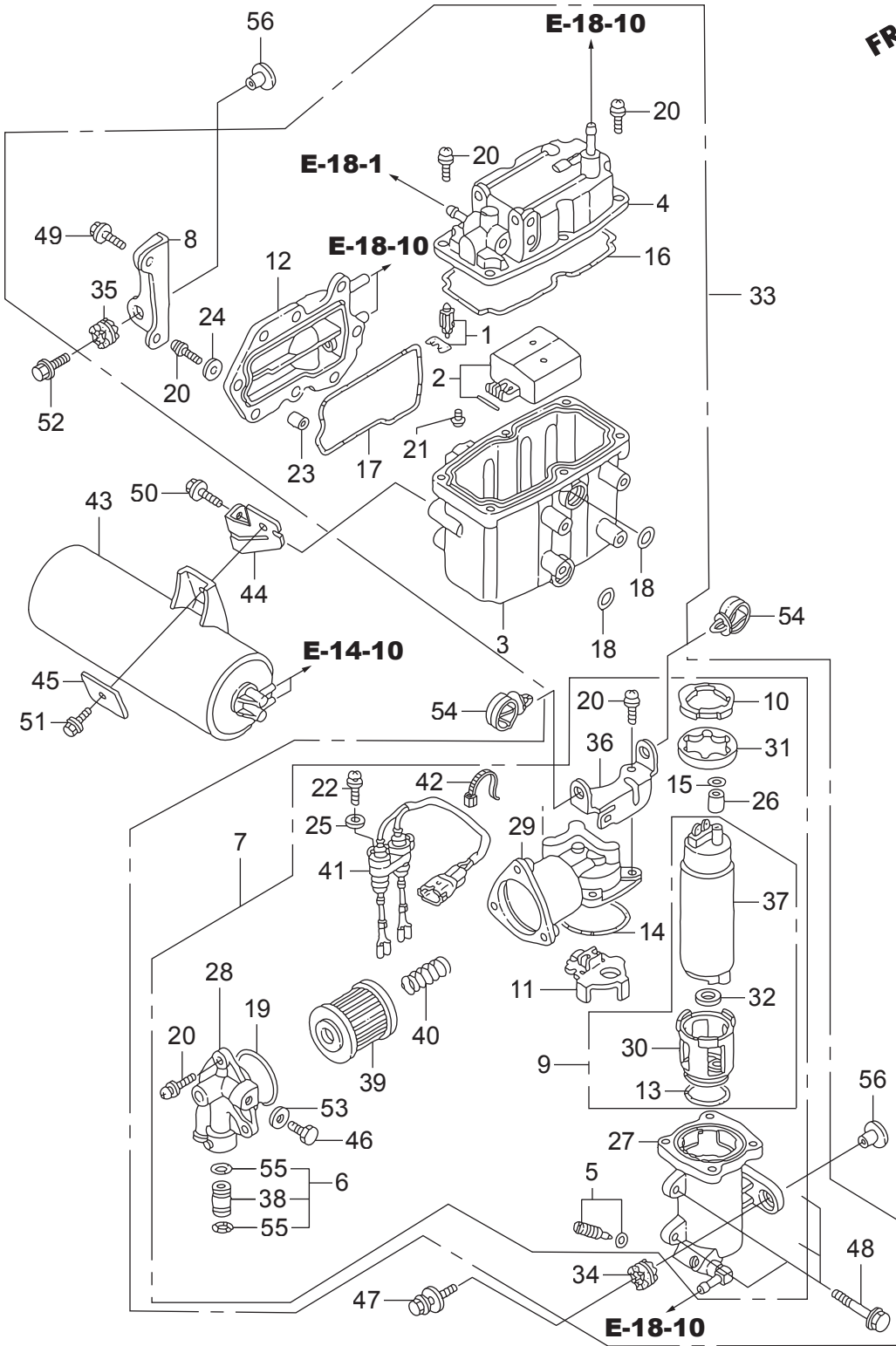

Ref.No.	Part No.	Description	Q' ty	Remarks	
			BFT250A		
E-18	30	HZY6-16718-013	INSULATOR COMP.	1	
E-18	31	HZY3-16721-000	INSULATOR	1	
E-18	32	HZY6-16723-003	RING	1	
E-18	33	HZX2-16730-003	SEPARATOR ASSY., VAPOR	1	
E-18	34	HZW5-16733-000	GROMMET, VAPOR SEPARATOR	1	
E-18	35	HZY3-16733-000	GROMMET, VAPOR SEPARATOR	2	
E-18	36	HZY3-16734-000	STAY, PLATE	1	
E-18	37	HZY3-16735-004	PUMP UNIT, FUEL	1	
E-18	38	HZY3-16752-000	JOINT, FUEL PIPE	1	
E-18	39	HZY3-16911-010	SCREEN COMP., FUEL STRAINER	1	
E-18	40	HZY3-16913-000	SPRING, SET	1	
E-18	41	HZX2-32166-003	HARNESS COMP.	1	
E-18	42	HZW5-32168-003	BAND	1	
E-18	43	HPR7-36361-A01	TANK COMP., VACUUM	1	
E-18	44	HZY3-36362-000	STAY, VACUUM TANK	1	
E-18	45	HZY3-36620-000	PLATE	1	
E-18	46	HPP4-90009-E01	BOLT, SEALING, 6MM	1	
E-18	47	HZW1-90014-000	BOLT-WASHER, 8X35	1	
E-18	48	HZW9-90016-000	BOLT, FLANGE, 6X25	4	
E-18	49	HZY3-90017-000	BOLT, FLANGE, 6X16	2	
E-18	50	HZY3-90021-000	BOLT, FLANGE, 6X14	2	
E-18	51	HZY3-90050-000	BOLT, FLANGE, 6X12	1	
E-18	52	HZY3-90054-000	BOLT, FLANGE, 8X35	2	
E-18	53	HPD6-90430-003	WASHER, SEALING, 6MM	1	
E-18	54	HZB7-90691-003	CLIP, HARNESS	2	
E-18	55	HMJ0-91301-003	O-RING, 7.8X1.9(ARAI)	2	
E-18	56	HZW1-91554-000	COLLAR, 8.5X14.5	3	

Ref.No.	Part No.	Description	Q' ty	Remarks	
			BFT250A		
E-18-1	1	HGHB-16163-600	CLIP, TUBE	1	
E-18-1	2	HZY3-16753-000	STAY, FUEL PIPE A	1	
E-18-1	3	HZY3-16754-000	STAY, FUEL PIPE B	2	
E-18-1	4	HZX2-16800-003	SEPARATOR ASSY., WATER	1	
E-18-1	5	HZX2-16805-003	CUP SET, WATER SEPARATOR	1	
E-18-1	6	HZY3-16807-003	BUFFER, PLATE	1	
E-18-1	7	HZX2-16814-000	STAY, WATER SEPARATOR	1	
E-18-1	8	HZX2-16860-C00	TUBE COMP. B, FUEL	1	
E-18-1	9	HZX2-16880-C00	TUBE COMP. D, FUEL	1	
E-18-1	10	HZX2-16890-C00	TUBE COMP. E, FUEL	1	
E-18-1	11	HZX2-16900-003	STRAINER ASSY., FUEL	1	
E-18-1	12	HZZ5-16901-003	FILTER	1	
E-18-1	14	HZY3-16904-003	SCREW, PAN, 5X12	3	
E-18-1	15	HZZ5-16906-003	FLOAT	1	
E-18-1	16	HZX2-16912-003	CUP	1	
E-18-1	17	HZX2-16914-000	STAY, FUEL STRAINER	1	
E-18-1	18	HZY3-16915-010	SUSPENSION, STRAINER	1	
E-18-1	19	HZZ5-16915-000	SUSPENSION, STRAINER	1	
E-18-1	20	HZY3-16918-003	O-RING	1	
E-18-1	21	HZZ5-16918-003	O-RING	1	
E-18-1	22	HZY3-16919-003	PLATE	1	
E-18-1	23	HZZ5-16919-003	O-RING	1	
E-18-1	24	HZX2-16940-003	COCK ASSY., FUEL DRAIN	1	
E-18-1	25	HZW9-90014-000	BOLT, FLANGE, 6X10	2	
E-18-1	26	HZY3-90056-000	BOLT, FLANGE, 6X12	3	
E-18-1	27	H921-90602-000	CLIP, TUBE(B8)	1	
E-18-1	28	HZV0-90604-000	CLIP, TUBE(B12)	2	
E-18-1	29	HZV4-90605-000	CLIP, TUBE(B12.5)	2	LA.XA,XCA
E-18-1	30	HKG4-90659-000	CLAMP, WIRE, 8MM	3	

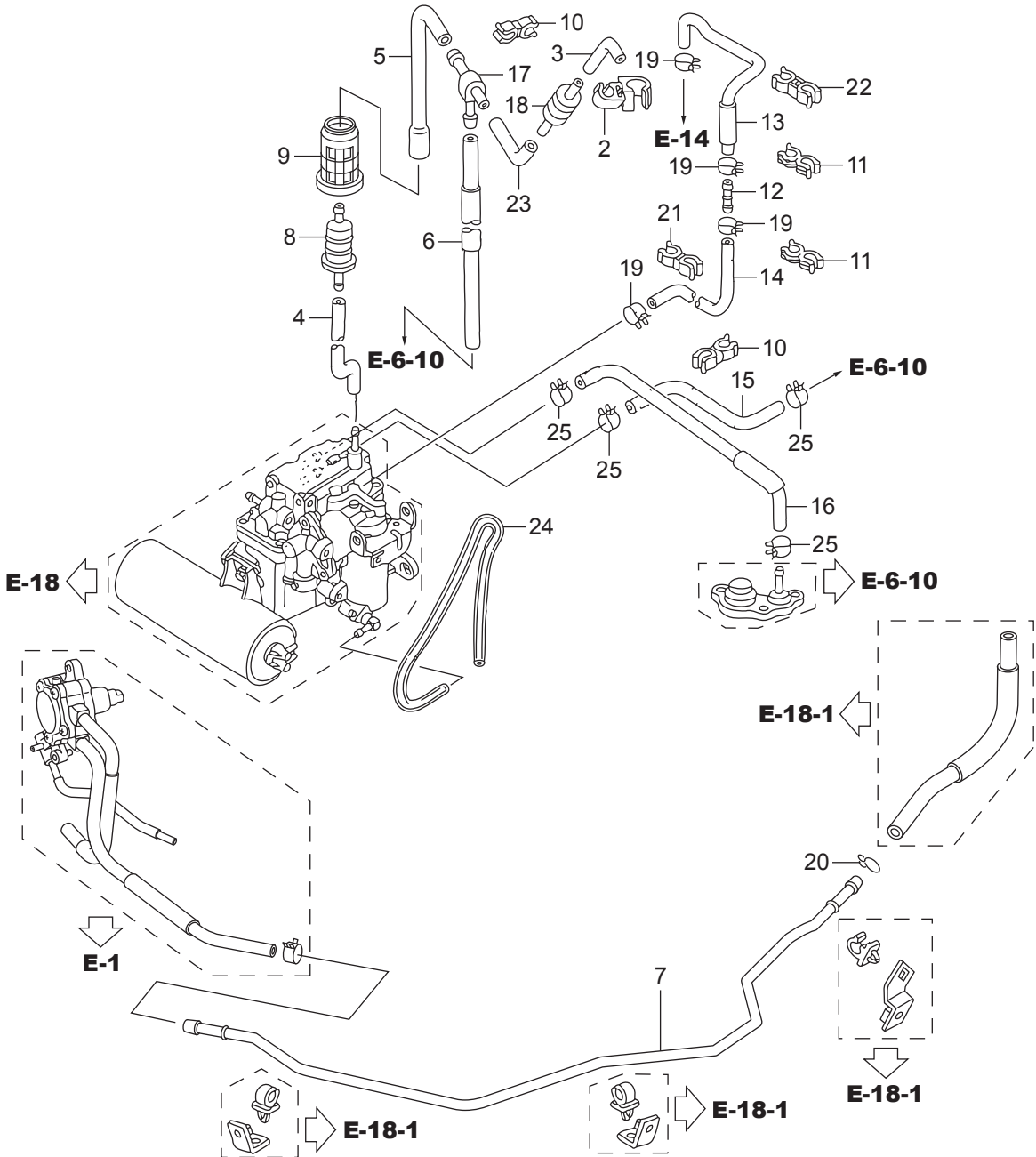

Ref.No.	Part No.	Description	Q' ty	Remarks	
			BFT250A		
E-18-10	2	HZY3-16193-A00	CLAMP, CHECK VALVE	1	
E-18-10	3	HZY3-16196-A00	TUBE, CHECK VALVE	1	
E-18-10	4	HZY3-16197-000	TUBE A, AIR VENT	1	
E-18-10	5	HZY3-16198-A00	TUBE B, AIR VENT	1	
E-18-10	6	HZY3-16199-A00	TUBE COMP., AIR VENT	1	
E-18-10	7	HZY3-16751-000	PIPE, FUEL	1	
E-18-10	8	H759-16911-003	STRAINER, FUEL PUMP	1	
E-18-10	9	HZW5-16915-000	SUSPENSION, STRAINER	1	
E-18-10	10	HVM0-16965-771	CLAMP, HOSE	2	
E-18-10	11	HKY7-17450-740	CLIP, TUBE	2	
E-18-10	12	HZY3-17721-000	JOINT, FUEL RETURN	1	
E-18-10	13	HZY3-17723-A01	HOSE A, PRESSURE REGULATOR RETURN	1	
E-18-10	14	HZY3-17724-010	HOSE B, PRESSURE REGULATOR RETURN	1	
E-18-10	15	HZY3-19258-010	TUBE, WATER IN.	1	
E-18-10	16	HZY3-19259-000	TUBE, WATER OUTLET	1	
E-18-10	17	HZY6-19269-000	T-JOINT	1	
E-18-10	18	HZY6-36135-003	VALVE, CHECK	1	
E-18-10	19	HZW5-90601-030	CLAMP, TUBE(D10.7)	4	
E-18-10	20	HZV0-90604-000	CLIP, TUBE(B12)	1	
E-18-10	21	HMB1-90655-921	CLIP, WIRE	1	
E-18-10	22	HSL0-91592-A51	CLAMP, FUEL TUBE	1	
E-18-10	23	HCO-95001-35055-40	TUBE, FUEL, 3.5X55	1	(HC-95001-35001-60M)
E-18-10	24	HCO-95003-05060-31	TUBE, VINYL, 3.5X6.5X600	1	(HC-95003-05001-60M)
E-18-10	25	HZY3-90601-030	CLAMP, TUBE(D10.5)	4	

FR. 

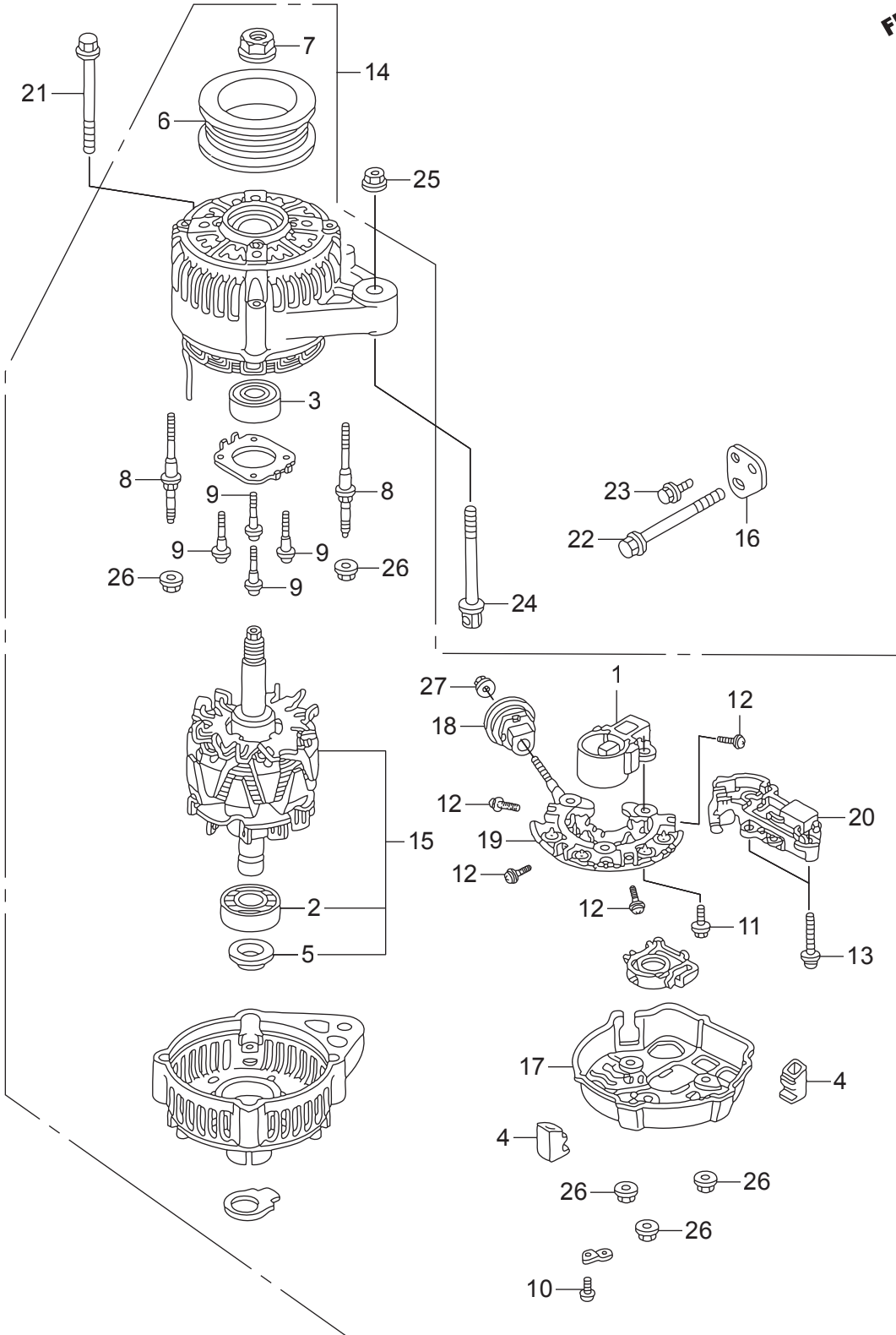

Ref.No.	Part No.	Description	Q' ty	Remarks	
			BFT250A		
E-19	1	HPR7-31105-A01	HOLDER ASSY., BRUSH	1	
E-19	2	HPT0-31111-003	BEARING, RR. GENERATOR	1	
E-19	3	HPT0-31114-013	BEARING, FR. GENERATOR	1	
E-19	4	HPT0-31118-003	BUSH, INSULATION	4	
E-19	5	HPD1-31138-004	COVER, BEARING	1	
E-19	6	HP13-31141-003	PULLEY	1	
E-19	7	HPD1-31142-004	NUT, PULLEY LOCK	1	
E-19	8	HPD1-31145-004	BOLT, STUD, 6X68	4	
E-19	9	HPT0-31146-003	SCREW	4	
E-19	10	HP13-31147-003	SCREW	1	
E-19	11	HPT0-31147-003	SCREW-WASHER	3	
E-19	12	HP13-31148-003	SCREW, WAVE WASHER	4	
E-19	13	HPT0-31148-003	SCREW, WAVE WASHER	2	
E-19	14	HZY3-31630-003	GENERATOR ASSY., A.C.	1	LA,XA,XCA
E-19	14	HZY3-31630-013	GENERATOR ASSY., A.C.	1	XXA,XXCA
E-19	15	HZY3-31631-003	ROTOR ASSY.	1	
E-19	16	HZY3-31637-000	STAY, A.C. GENERATOR	1	
E-19	17	HZY3-31639-003	END COVER, RR.	1	
E-19	18	HZY3-31694-003	BUSH, INSULATION	1	
E-19	19	HZY3-31710-003	RECTIFIER ASSY.	1	
E-19	20	HZY3-31750-003	REGULATOR ASSY.	1	
E-19	21	HZX2-90002-000	BOLT, FLANGE, 10X90	1	
E-19	22	HZW5-90011-010	BOLT, SPECIAL ADJUSTER	1	
E-19	23	HZY3-90017-000	BOLT, FLANGE, 6X16	1	
E-19	24	HZY3-90055-000	BOLT, TENSIONER	1	
E-19	25	HZW5-90203-010	NUT, FLANGE, 8MM	1	
E-19	26	HPD1-90231-014	NUT-WASHER, 5MM	7	
E-19	27	HCO-94001-06080-0S	NUT, HEX., 6MM	1	

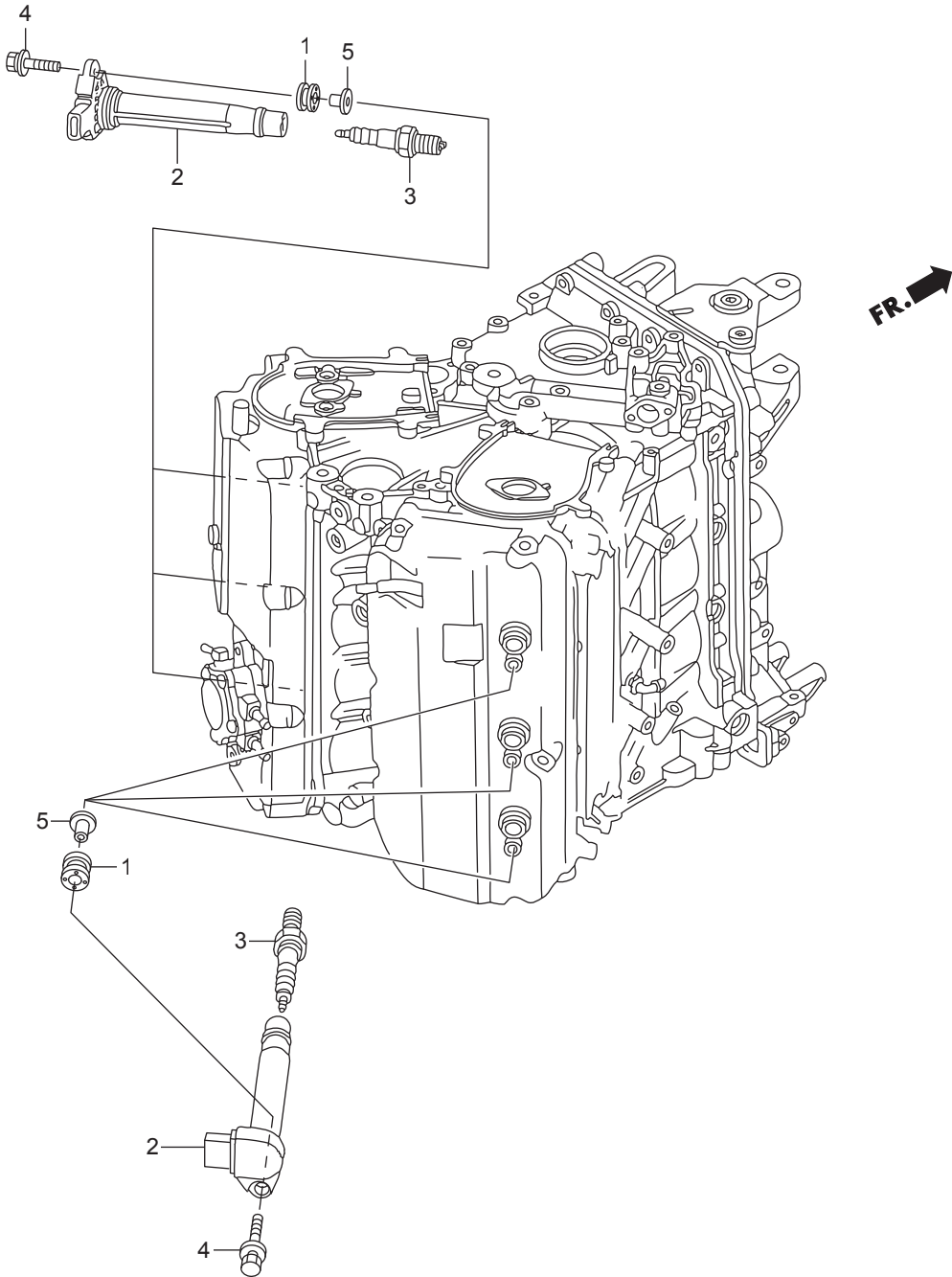

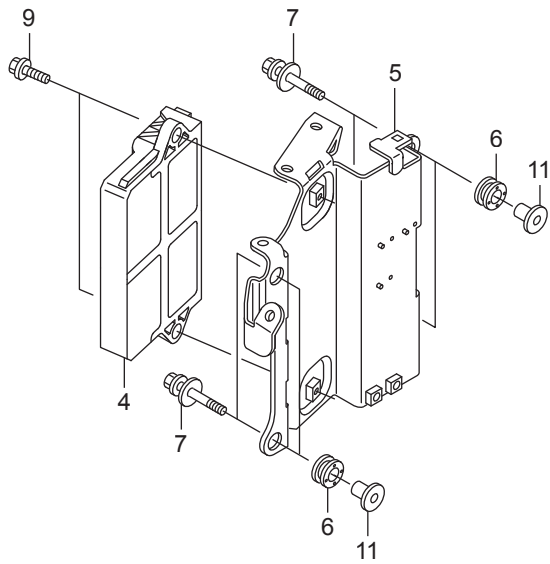
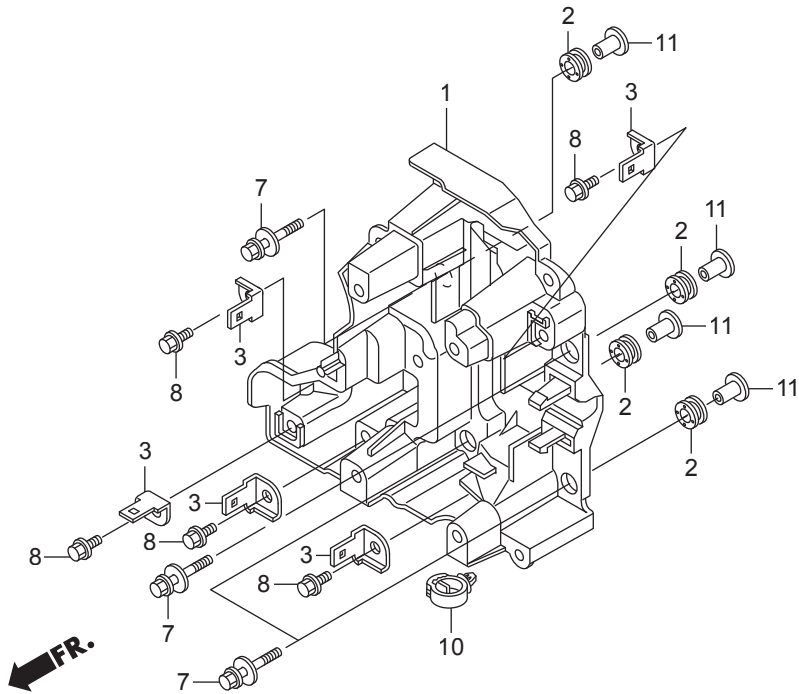

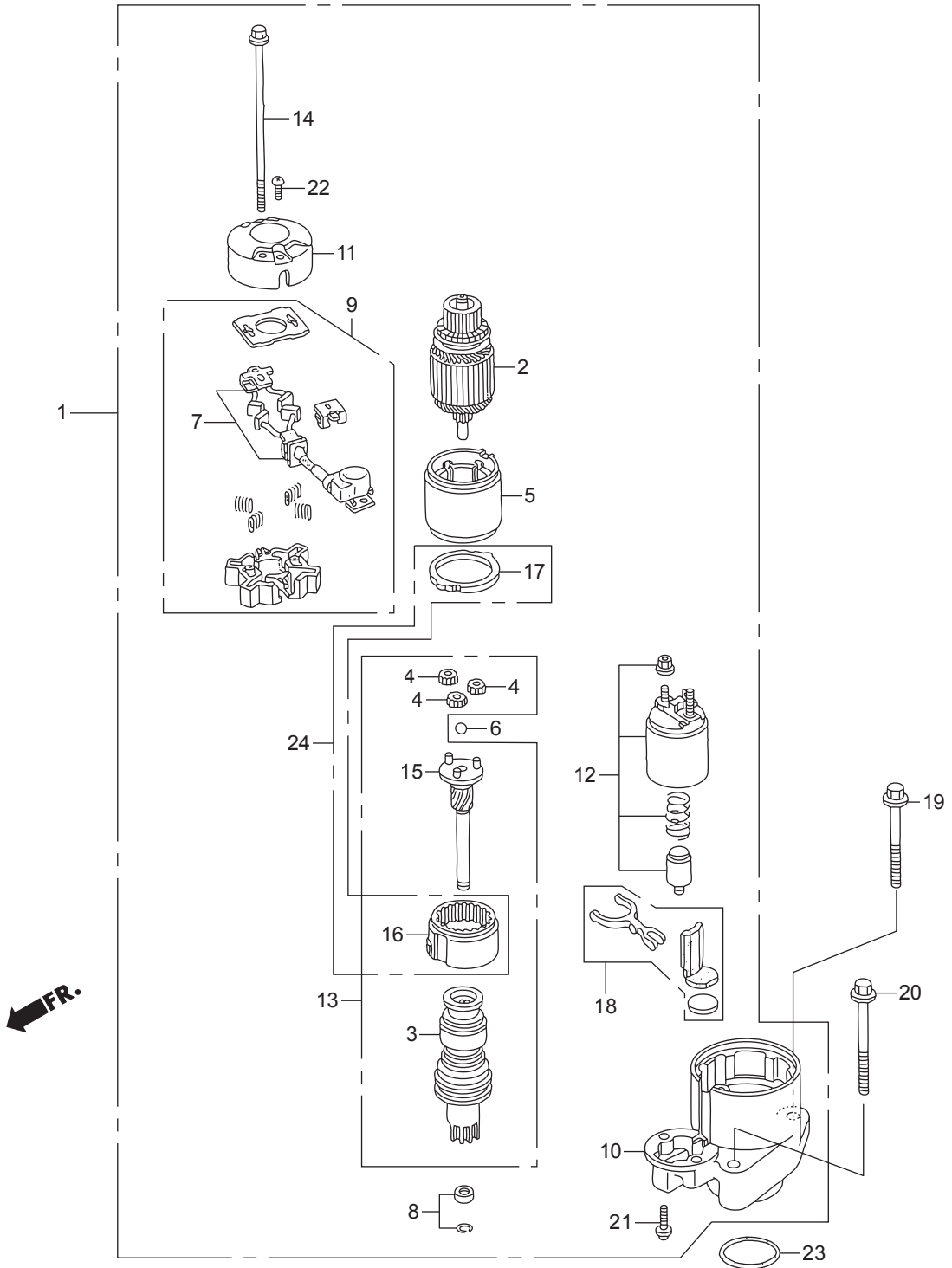

Ref.No.	Part No.	Description	Q' ty	Remarks	
			BFT250A		
E-21	1	HZY3-31200-003	MOTOR ASSY., STARTER	1	
E-21	2	HP5A-31201-005	ROTOR COMP.	1	
E-21	3	HZY3-31207-003	CLUTCH COMP., OVERRUNNING	1	LA,XA,XCA #~1003981
E-21	3	HZY9-31207-H01	CLUTCH COMP., OVERRUNNING	1	LA,XA,XCA #1003982~ XXA,XXCA
E-21	4	HPY3-31215-004	GEAR ASSY., PLANETARY	3	
E-21	5	HZY3-31216-003	YOKE COMP.	1	
E-21	6	HPY3-31218-004	BALL, STEEL	1	
E-21	7	HZW1-31226-004	BRUSH SET	1	LA,XA,XCA #~1003981
E-21	7	HZY3-31226-003	BRUSH SET	1	LA,XA,XCA #1003982~ XXA,XXCA
E-21	8	HZW1-31229-004	STOPPER SET, SLEEVE	1	LA,XA,XCA #~1003981
E-21	8	HZY9-31229-H01	STOPPER SET, SLEEVE	1	LA,XA,XCA #1003982~ XXA,XXCA
E-21	9	HZW1-31231-004	HOLDER COMP., BRUSH	1	LA,XA,XCA #~1003981
E-21	9	HZY3-31232-003	HOLDER COMP., BRUSH	1	LA,XA,XCA #1003982~ XXA,XXCA #1003982~
E-21	10	HZY3-31235-003	BRACKET, FR.	1	
E-21	11	HZY3-31236-003	BRACKET, RR.	1	
E-21	12	HZY3-31240-003	SWITCH ASSY., MAGNET	1	LA,XA,XCA #~1003981
E-21	12	HZY3-31241-003	SWITCH ASSY., MAGNET	1	LA,XA,XCA #1003982~ XXA,XXCA #1003982~
E-21	13	HZY3-31242-003	SHAFT ASSY., CLUTCH	1	LA,XA,XCA #~1003981
E-21	13	HZY3-31243-003	SHAFT ASSY., CLUTCH	1	LA,XA,XCA #1003982~ XXA,XXCA
E-21	14	HP5A-31243-005	BOLT A, THROUGH	2	
E-21	15	HZY3-31246-003	SHAFT ASSY., GEAR	1	LA,XA,XCA #~1003981
E-21	15	HZY9-31246-H01	SHAFT ASSY., GEAR	1	LA,XA,XCA #1003982~ XXA,XXCA

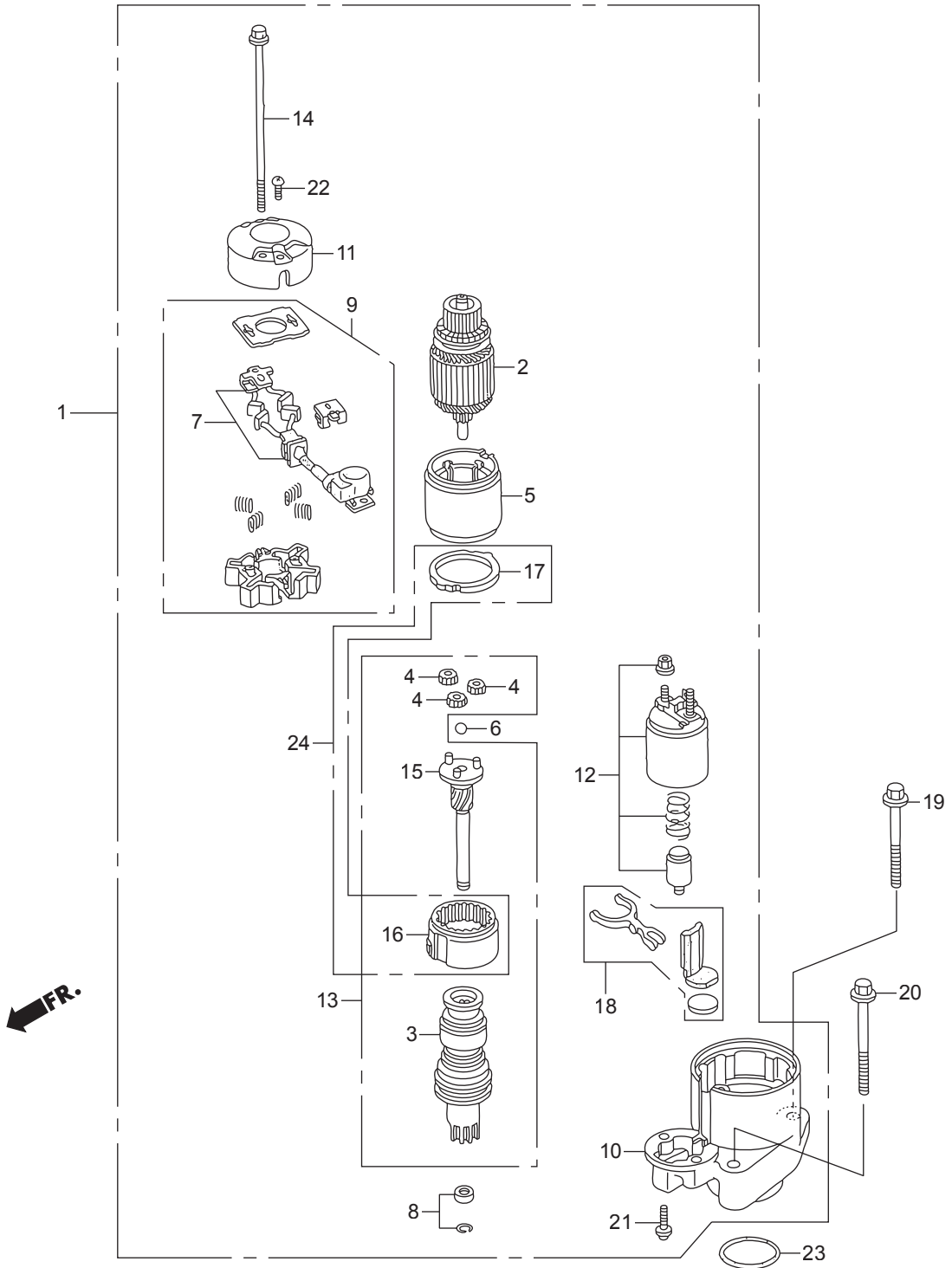

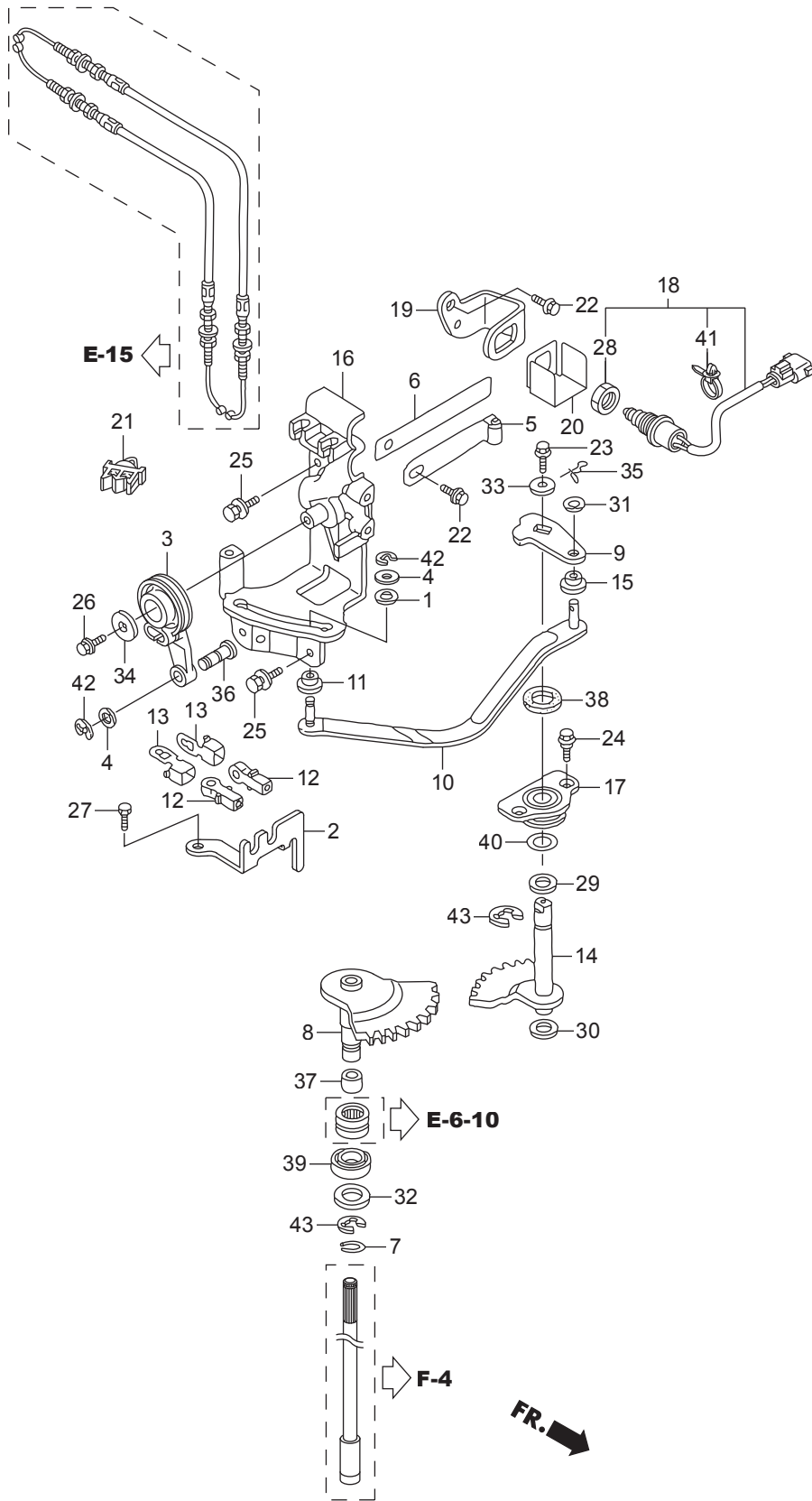

Ref.No.	Part No.	Description	Q' ty	Remarks	
			BFT250A		
F-2	1	HKN5-17224-670	WASHER, AIR CLEANER COVER SETTING	1	
F-2	2	HZY3-17877-000	PLATE, REMOTE CONTROL CABLE	1	
F-2	3	HZY3-17931-000	ARM, THROTTLE	1	
F-2	4	H921-17936-000	WASHER, PIVOT	2	
F-2	5	HZW1-24210-010	SPRING COMP., CLICK	1	
F-2	6	HZY3-24221-000	SPRING, CLICK ASSIST	1	
F-2	7	HZW1-24327-000	RING, STOPPER	1	
F-2	8	HZY3-24610-A00	SHAFT COMP., SHIFT(A)	1	
F-2	9	HZY3-24612-010	ARM, SHIFT	1	
F-2	10	HZY3-24613-000	ROD, LINK	1	
F-2	11	HZY3-24617-000	COLLAR, SHIFT SLIDER	1	
F-2	12	HZY3-24618-000	PIVOT, SHIFT	2	
F-2	13	HZY3-24619-000	PLATE, LOCK	2	
F-2	14	HZY3-24620-000	SHAFT COMP., SHIFT(B)	1	
F-2	15	HZY3-24623-000	BUSH, SHIFT ARM	1	
F-2	16	HZY3-24628-000	BRACKET, SHIFT LINK	1	
F-2	17	HZW1-24629-000	HOLDER, SEAL	1	
F-2	18	HZX2-35470-013	SWITCH ASSY., NEUTRAL	1	
F-2	19	HZY3-35476-010	BRACKET, NEUTRAL SWITCH	1	
F-2	20	HZY3-35477-000	COVER, NEUTRAL SWITCH	1	
F-2	21	HS0X-46392-A01	CLIP, BRAKE PIPE	1	
F-2	22	HZW9-90011-000	BOLT, FLANGE, 6X14(CT200)	2	
F-2	23	HZY3-90017-000	BOLT, FLANGE, 6X16	1	
F-2	24	HZW5-90023-000	BOLT, FLANGE, 6X11	2	
F-2	25	HZX2-90101-C00	BOLT-WASHER, 6X16	3	
F-2	26	HZW9-90102-000	BOLT, FLANGE, 6X12	1	
F-2	27	HZV4-90127-000	BOLT, HEX., 6X16	1	
F-2	28	HZV5-90302-003	NUT, HEX., 20MM	1	
F-2	29	HHA0-90402-000	WASHER, THRUST, 14MM	1	

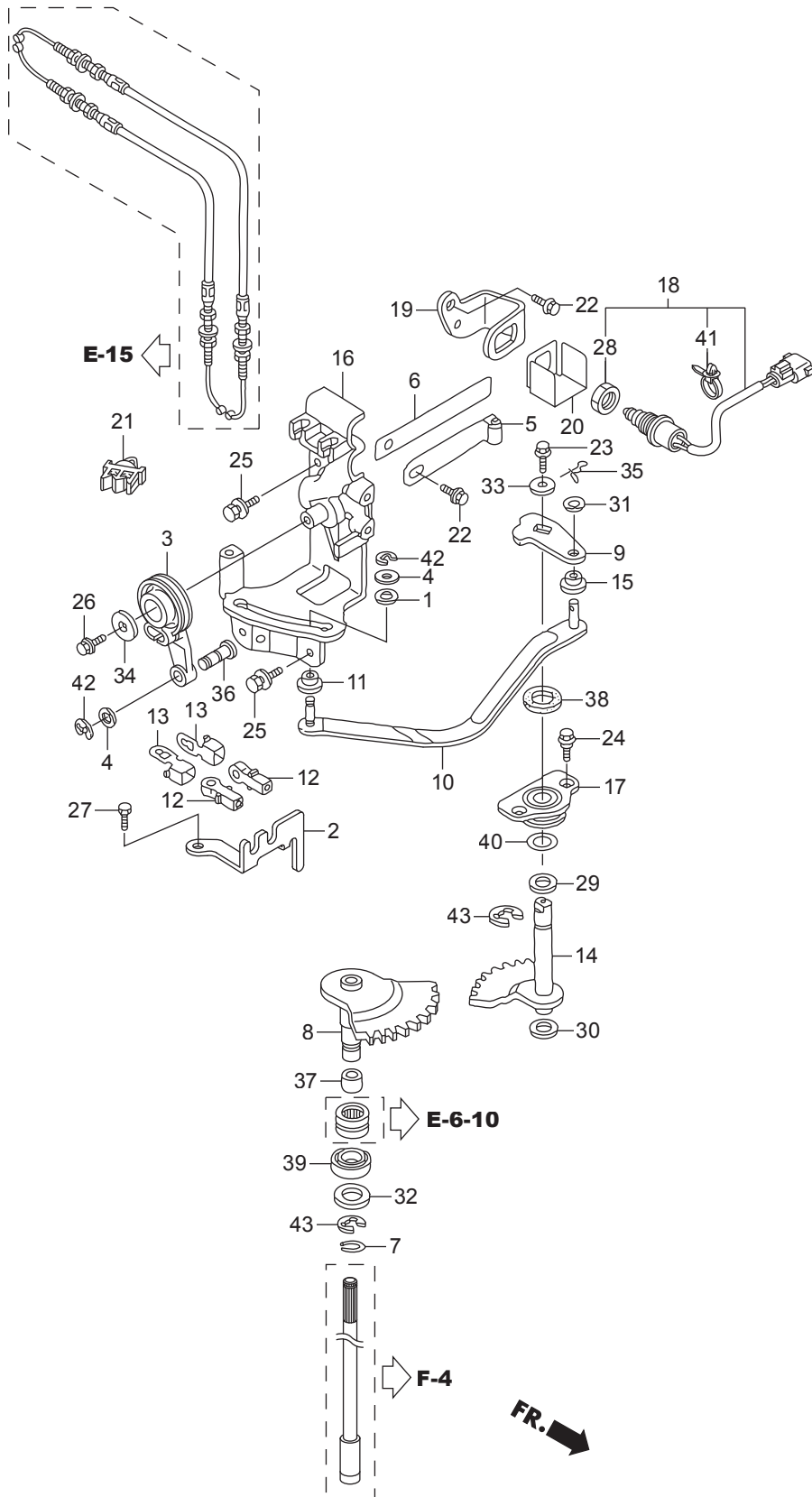

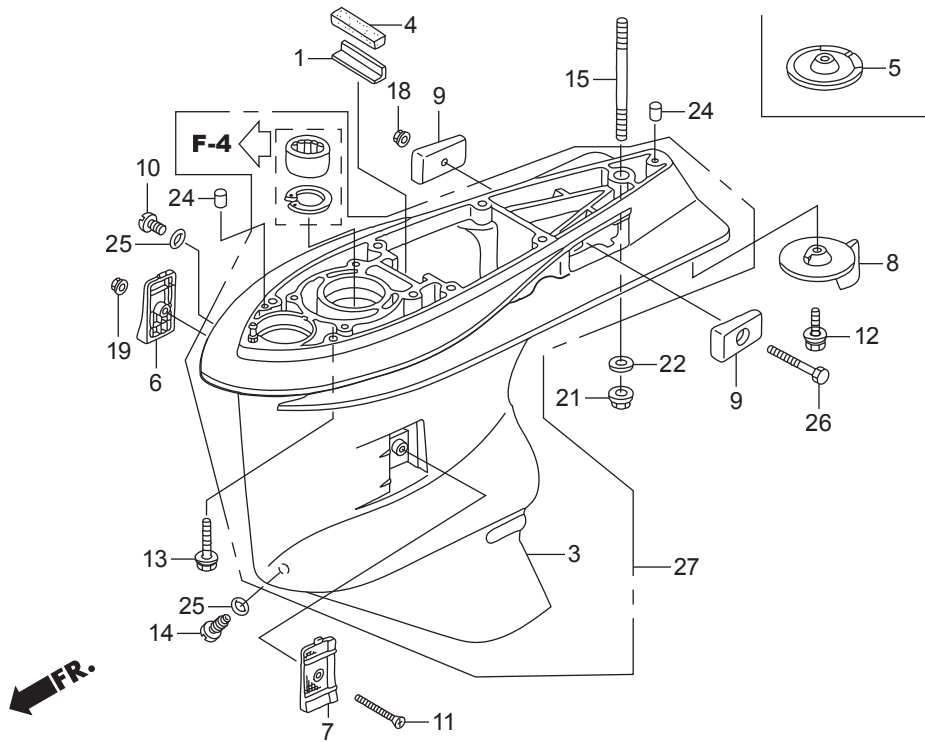
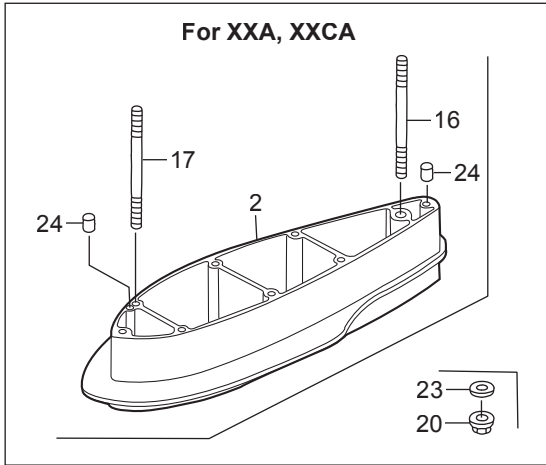

Ref.No.	Part No.	Description	Q' ty	Remarks	
			BFT250A		
F-3	1	HZW1-19286-B00	PLATE, RUBBER SETTING	1	
F-3	2	HZY3-40202-621ZC	SEPARATOR, EXTENSION	1	*T107*BAY BLUE XXA,XXCA
F-3	3	HZX2-41101-C01ZC	CASE, GEAR	1	*T107*BAY BLUE
F-3	4	HZW1-41102-B00	GROMMET, GEAR CASE	1	
F-3	5	HZX2-41102-E00ZC	COVER, GEAR CASE	1	*T107*BAY BLUE XCA,XXCA
F-3	6	HZY3-41104-C01	SCREEN, R. WATER	1	
F-3	7	HZY3-41105-C01	SCREEN, L. WATER	1	
F-3	8	HZX2-41107-C00ZC	TAB, TRIM	1	*T107*BAY BLUE LA,XA,XXA
F-3	9	HZW1-41109-B00	METAL COMP., ANODE	2	
F-3	10	HZW9-90101-003	BOLT, OIL CHECK	1	
F-3	11	HZZ0-90101-000	SCREW, FLAT, 5X55	1	
F-3	12	HZY6-90103-000	BOLT-WASHER, 10X32	1	
F-3	13	HZX2-90107-C00	BOLT-WASHER, 10X47	6	LA,XA,XCA
F-3	14	HZY3-90120-000	BOLT, DRAIN PLUG	1	
F-3	15	HZY3-90124-000	BOLT, STUD, 12X40	1	LA,XA,XCA
F-3	16	HZY3-90130-620	BOLT, STUD, 12X170	1	XXA,XXCA
F-3	17	HZY3-90131-620	BOLT, STUD, 10X170	6	XXA,XXCA
F-3	18	HZY1-90205-000	NUT, SELF-LOCK, 6MM	1	
F-3	19	HZV4-90302-000	NUT, SELF-LOCK, 5MM	1	
F-3	20	HZV5-90306-003	NUT, SELF-LOCK, 10MM	6	XXA,XXCA
F-3	21	HZW1-90308-003	NUT, SELF-LOCK, 12MM	1	
F-3	22	HZV5-90559-000	WASHER, PLAIN, 12MM	1	
F-3	23	HZV5-90563-000	WASHER, PLAIN, 10MM	6	XXA,XXCA
F-3	24	HZV5-90756-000	DOWEL PIN, 6X10	2	LA,XA,XCA
F-3	24	HZV5-90756-000	DOWEL PIN, 6X10	4	XXA,XXCA
F-3	25	HZW4-91301-003	O-RING, 6.9X1.45	2	
F-3	26	HCO-92101-06055-4J	BOLT, HEX., 6X55	1	
F-3	27	HZX2-41110-305ZB	CASE COMP., GEAR	1	*T107*BAY BLUE

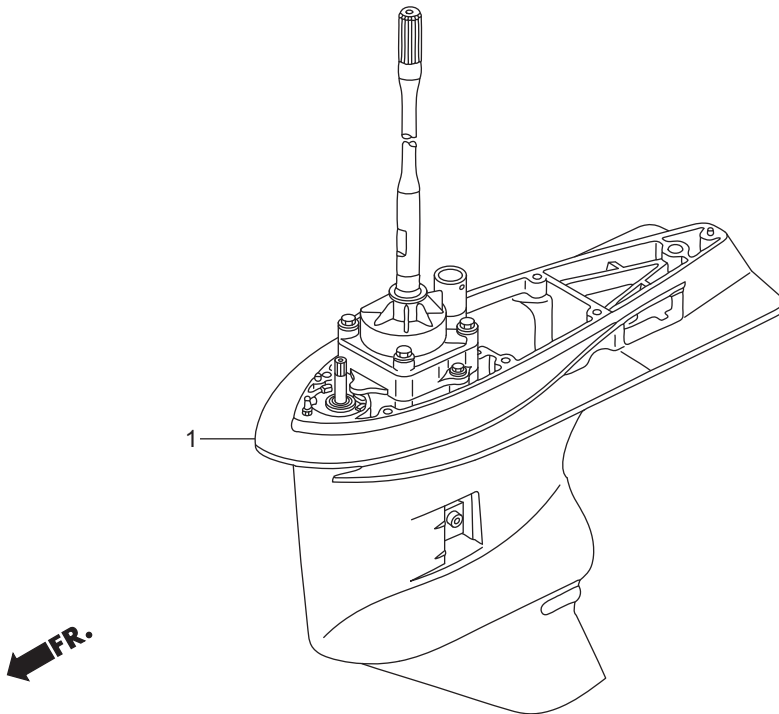

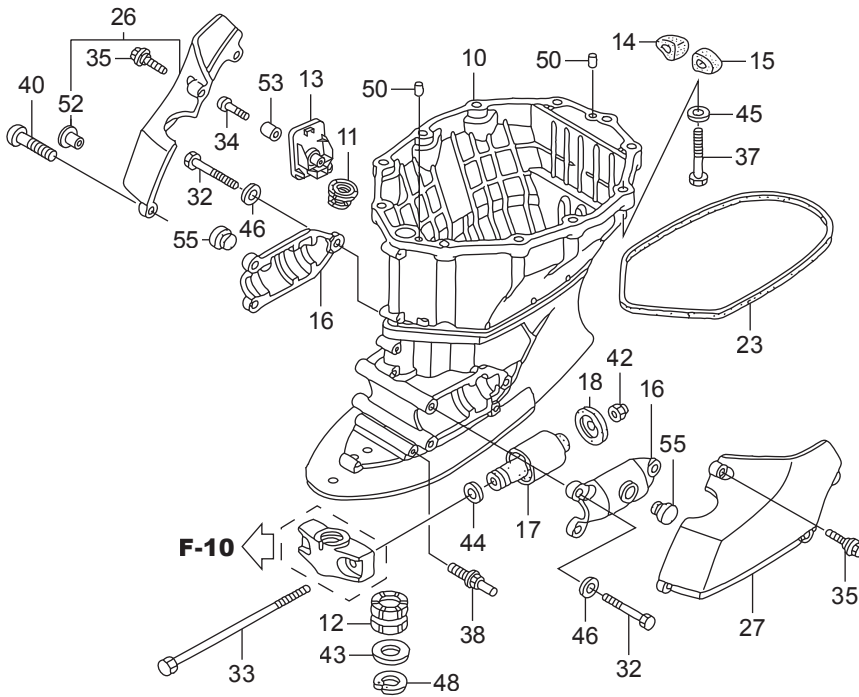
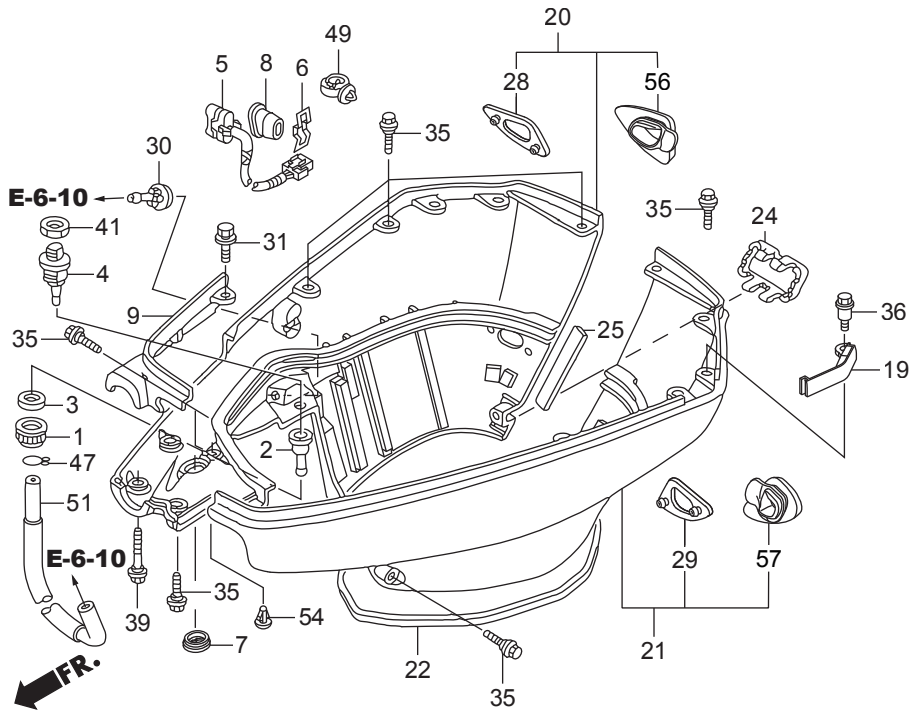

Ref.No.	Part No.	Description	Q' ty	Remarks	
			BFT250A		
F-3-20	1	HZY3-19270-000	NUT, WATER MOUTH	1	
F-3-20	2	HZY3-19271-000	JOINT, WATER HOSE	1	
F-3-20	3	HZY3-19272-000	SEAT, WATER MOUTH	1	
F-3-20	4	HZY3-19289-000	CAP, WATER JOINT	1	
F-3-20	5	HZY3-35640-013	SWITCH ASSY., POWER TILT	1	
F-3-20	6	HZY3-35645-000	STAY, POWER TILT SWITCH	1	
F-3-20	7	HZV5-40107-000	GROMMET, UNDER CASE(C)	1	
F-3-20	8	HZY3-40114-010	GROMMET, POWER TILT SWITCH	1	
F-3-20	9	HZY3-40151-000ZC	COVER, FR. SEPARATE	1	*T107*BAY BLUE
F-3-20	10	HZY3-40201-020ZC	CASE, EXTENSION	1	*T107*BAY BLUE LA
F-3-20	10	HZY3-40201-612ZC	CASE, EXTENSION	1	*T107*BAY BLUE XA,XCA,XXA,XXCA
F-3-20	11	HZW1-40209-000	RUBBER, DRAIN PLUG	1	
F-3-20	12	HZY3-40210-610	BUSH COMP., VERTICAL SHAFT	1	XA,XCA,XXA,XXCA
F-3-20	13	HZY3-40212-010ZC	COVER, DRAIN PLUG(L)	1	*T107*BAY BLUE LA
F-3-20	13	HZY3-40212-611ZC	COVER, DRAIN PLUG(XL)	1	*T107*BAY BLUE XA,XCA,XXA,XXCA
F-3-20	14	HZY3-40225-010	SEAL, R. IDOL PORT	1	XCA,XXCA
F-3-20	14	HZY3-40225-010	SEAL, R. IDOL PORT	1	#~6000122 LA,XA,XXA
F-3-20	15	HZY3-40226-010	SEAL, L. IDOL PORT	1	XCA,XXCA
F-3-20	15	HZY3-40226-010	SEAL, L. IDOL PORT	1	#~6000122 LA,XA,XXA
F-3-20	16	HZY3-50111-020	HOUSING, LOWER MOUNTING	2	
F-3-20	17	HZY3-50155-000	MOUNT COMP., LOWER RUBBER	2	
F-3-20	18	HZY3-50157-010	STOPPER, LOWER MOUNT	2	
F-3-20	19	HZY3-63347-C00	COVER, PLUG MAINTENANCE	1	
F-3-20	20	HZX2-63710-C00ZB	COVER COMP., R. UNDER ENGINE	1	*T107*BAY BLUE XCA,XXCA
F-3-20	20	HZX2-63710-C00ZB	COVER COMP., R. UNDER ENGINE	1	#~6000122 LA,XA,XXA
F-3-20	20	HZX2-63710-C01ZB	COVER COMP., R. UNDER ENGINE	1	*T107*BAY BLUE #6000123~ LA,XA,XXA
F-3-20	21	HZX2-63715-C00ZB	COVER COMP., L. UNDER ENGINE	1	*T107*BAY BLUE XCA,XXCA
F-3-20	21	HZX2-63715-C00ZB	COVER COMP., L. UNDER ENGINE	1	#~6000122 LA,XA,XXA
F-3-20	21	HZX2-63715-C01ZB	COVER COMP., L. UNDER ENGINE	1	*T107*BAY BLUE #6000123~ LA,XA,XXA

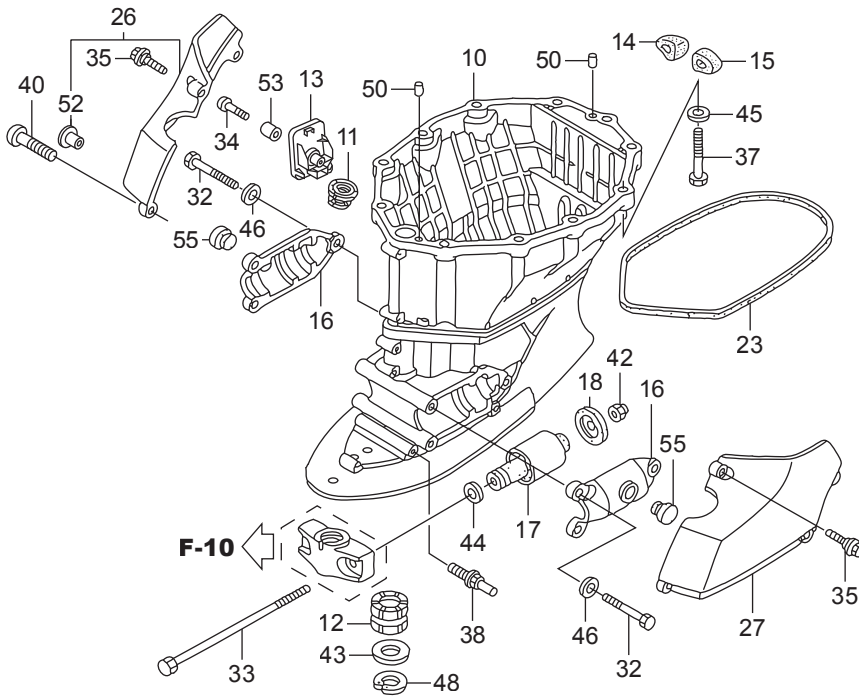
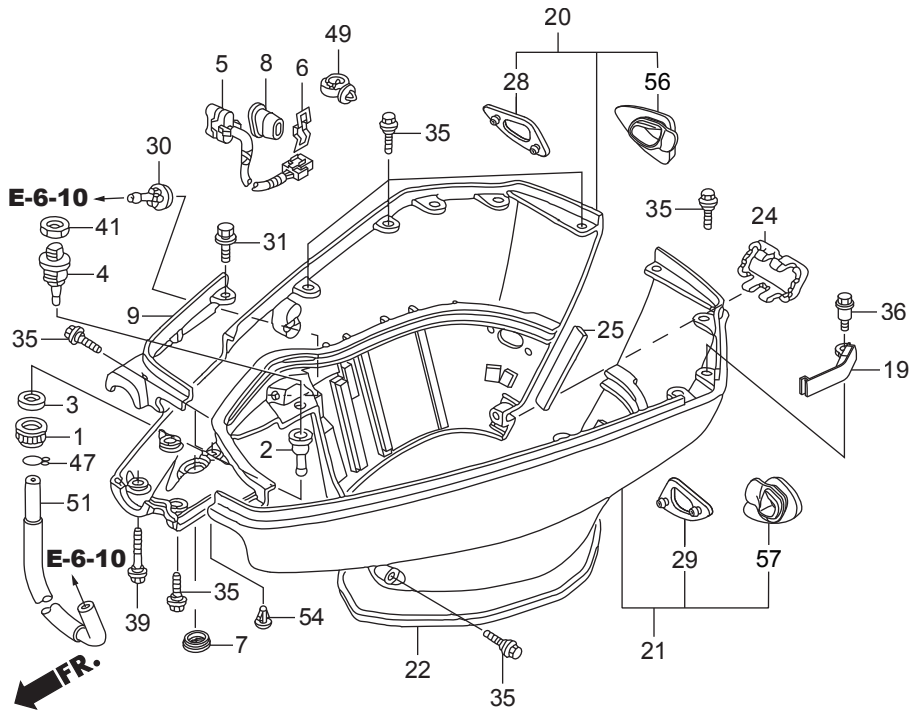

Ref.No.	Part No.	Description	Q' ty	Remarks	
			BFT250A		
F-3-20	22	HZY3-63718-000	SEAL A, COVER UNDER	1	
F-3-20	23	HZX2-63719-C00	SEAL B, COVER UNDER	1	
F-3-20	24	HZY3-63722-010ZC	CAP, UNDER COVER	1	*T107*BAY BLUE
F-3-20	25	HZY3-63728-000	SEAL C, UNDER COVER	1	
F-3-20	26	HZY3-63731-A03ZC	COVER, R. LOWER MOUNTING(L)	1	*T107*BAY BLUE LA
F-3-20	26	HZY3-63731-A12ZC	COVER, R. LOWER MOUNTING(XL)	1	*T107*BAY BLUE XA,XCA,XXA,XXCA
F-3-20	27	HZY3-63736-A03ZC	COVER, L. LOWER MOUNTING(L)	1	*T107*BAY BLUE LA
F-3-20	27	HZY3-63736-A12ZC	COVER, L. LOWER MOUNTING(XL)	1	*T107*BAY BLUE XA,XCA,XXA,XXCA
F-3-20	28	HZY3-63751-C00	GROMMET, R. IDLE PORT	1	XCA,XXCA
F-3-20	28	HZY3-63751-C00	GROMMET, R. IDLE PORT	1	#~6000122 LA,XA,XXA
F-3-20	29	HZY3-63756-C00	GROMMET, L. IDLE PORT	1	XCA,XXCA
F-3-20	29	HZY3-63756-C00	GROMMET, L. IDLE PORT	1	#~6000122 LA,XA,XXA
F-3-20	30	HZV5-82873-003	GROMMET, WATER CHECK	1	
F-3-20	31	HZX2-90102-C00	BOLT-WASHER, 6X25	2	
F-3-20	32	HZY3-90102-A00	BOLT, HEX., 10X35	6	
F-3-20	33	HZY3-90105-010	BOLT, HEX., 14X180	2	
F-3-20	34	HZV5-90110-000	SCREW, SPECIAL, 6X35	1	
F-3-20	35	HZY3-90111-000	BOLT, SPECIAL, 6X17	26	
F-3-20	36	HZY3-90113-C00	BOLT, SPECIAL, 6X22	1	
F-3-20	37	HZY3-90122-000	BOLT, HEX., 12X50	11	
F-3-20	38	HZY3-90129-A00	BOLT, SPECIAL, 6X12	2	
F-3-20	39	HZY3-90132-000	BOLT, SPECIAL, 6X37	2	
F-3-20	40	HZY3-90134-000	SCREW-WASHER, 6X40	1	LA
F-3-20	40	HCO-93500-06025-4J	SCREW, PAN, 6X25	1	XA,XCA,XXA,XXCA
F-3-20	41	H921-90302-000	NUT, HEX., 16MM	1	
F-3-20	42	HZY3-90302-000	NUT, SELF-LOCK, 14MM	2	
F-3-20	43	HZY3-90503-610	WASHER, 30MM	1	XA,XCA,XXA,XXCA
F-3-20	44	HZY3-90511-000	WASHER, PLAIN, 14MM	2	
F-3-20	45	HZV5-90559-000	WASHER, PLAIN, 12MM	11	

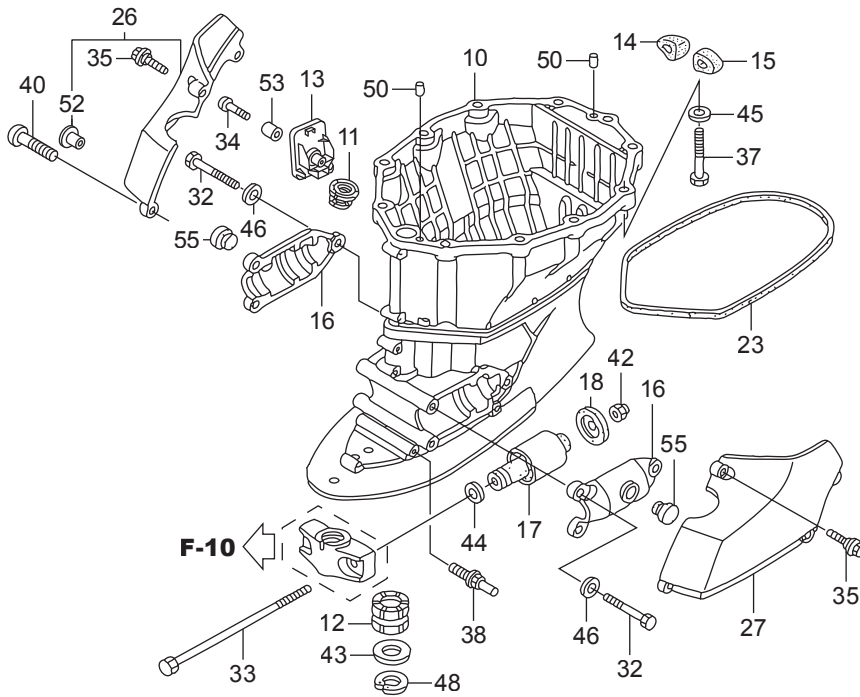
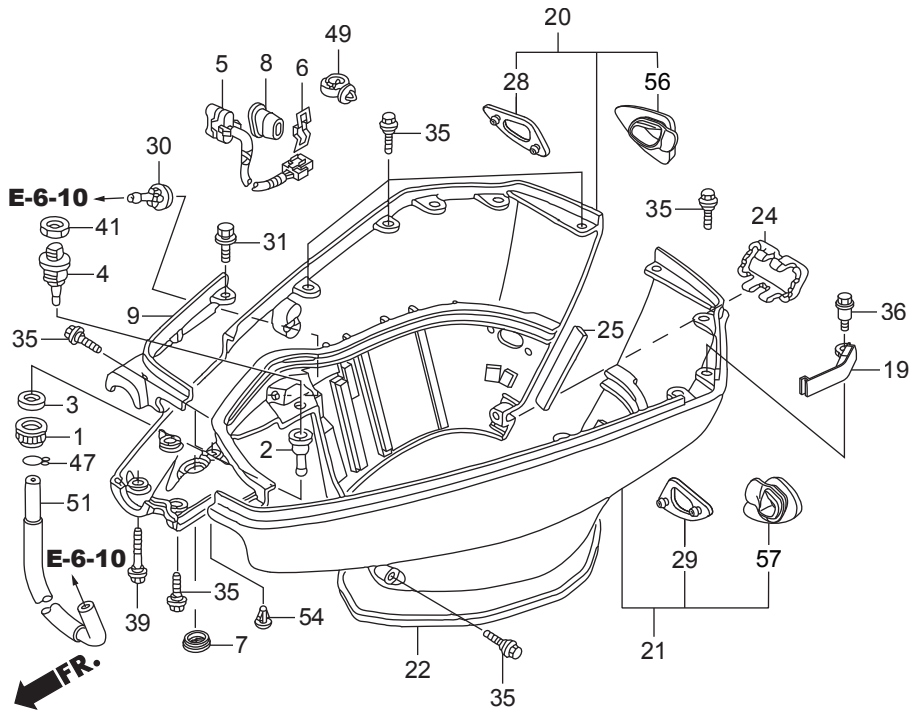

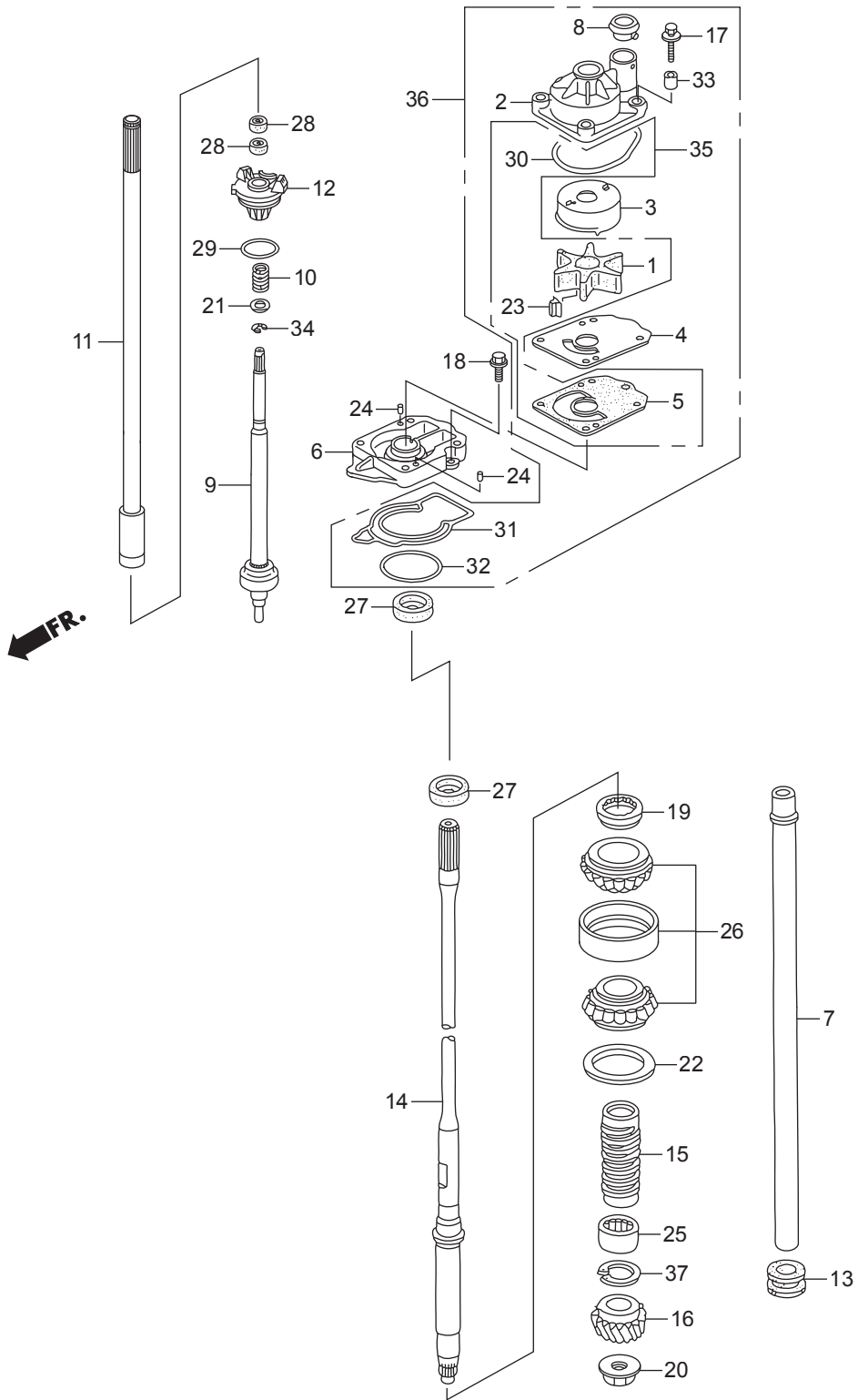

Ref.No.	Part No.	Description	Q' ty	Remarks	
			BFT250A		
F-4	1	HZY3-19210-003	IMPELLER, PUMP	1	
F-4	2	HZY3-19221-010	HOUSING, IMPELLER	1	
F-4	3	HZY3-19223-000	LINER, PUMP	1	
F-4	4	HZY3-19231-000	COVER, IMPELLER	1	
F-4	5	HZX2-19234-C00	GASKET B, IMPELLER	1	
F-4	6	HZX2-19241-C00	HOUSING, WATER PUMP	1	
F-4	7	HZY3-19251-000	TUBE, WATER(L)	1	LA
F-4	7	HZY3-19251-611	TUBE, WATER(XL)	1	XA,XCA
F-4	7	HZY3-19251-621	TUBE, WATER(XXL)	1	XXA,XXCA
F-4	8	HZY3-19253-000	RING, WATER TUBE SEAL	1	
F-4	9	HZY3-24310-C00	ROD COMP., SHIFT	1	LA,XA,XXA
F-4	9	HZY3-24310-E00	ROD COMP., SHIFT	1	(COUNTER ROTATION) XCA,XXCA
F-4	10	HZY3-24318-000	SPRING, SHIFT ROD	1	
F-4	11	HZY6-24320-000	ROD COMP. A, SHIFT(L)	1	LA
F-4	11	HZY6-24320-610	ROD COMP. A, SHIFT(XL)	1	XA,XCA
F-4	11	HZY3-24320-A20	ROD COMP. A, SHIFT(XXL)	1	XXA,XXCA
F-4	12	HZW1-24343-B02	HOLDER, SHIFT ROD	1	
F-4	13	HZY3-40204-000	GROMMET, EXTENSION CASE	1	
F-4	14	HZX2-41112-C00	SHAFT, VERTICAL(L)	1	LA
F-4	14	HZX2-41112-C10	SHAFT, VERTICAL(XL)	1	XA,XCA
F-4	14	HZX2-41112-C20	SHAFT, VERTICAL(XXL)	1	XXA,XXCA
F-4	15	HZY3-41116-000	SLINGER, OIL	1	
F-4	16	HZX2-41131-C00	GEAR, PINION	1	LA,XA,XXA
F-4	16	HZX2-41131-E00	GEAR, PINION(COUNTER ROTATION)	1	XCA,XXCA
F-4	17	HZX2-90105-C00	BOLT, WASHER, 8X60	4	
F-4	18	HHW1-90215-671	BOLT, FLANGE, 6X16	1	
F-4	19	HZX2-90301-C00	NUT, LOCK, 68MM	1	
F-4	20	HZX2-90303-C00	NUT, HEX., 18MM	1	
F-4	21	H723-90472-000	WASHER, PLAIN, 12MM	1	

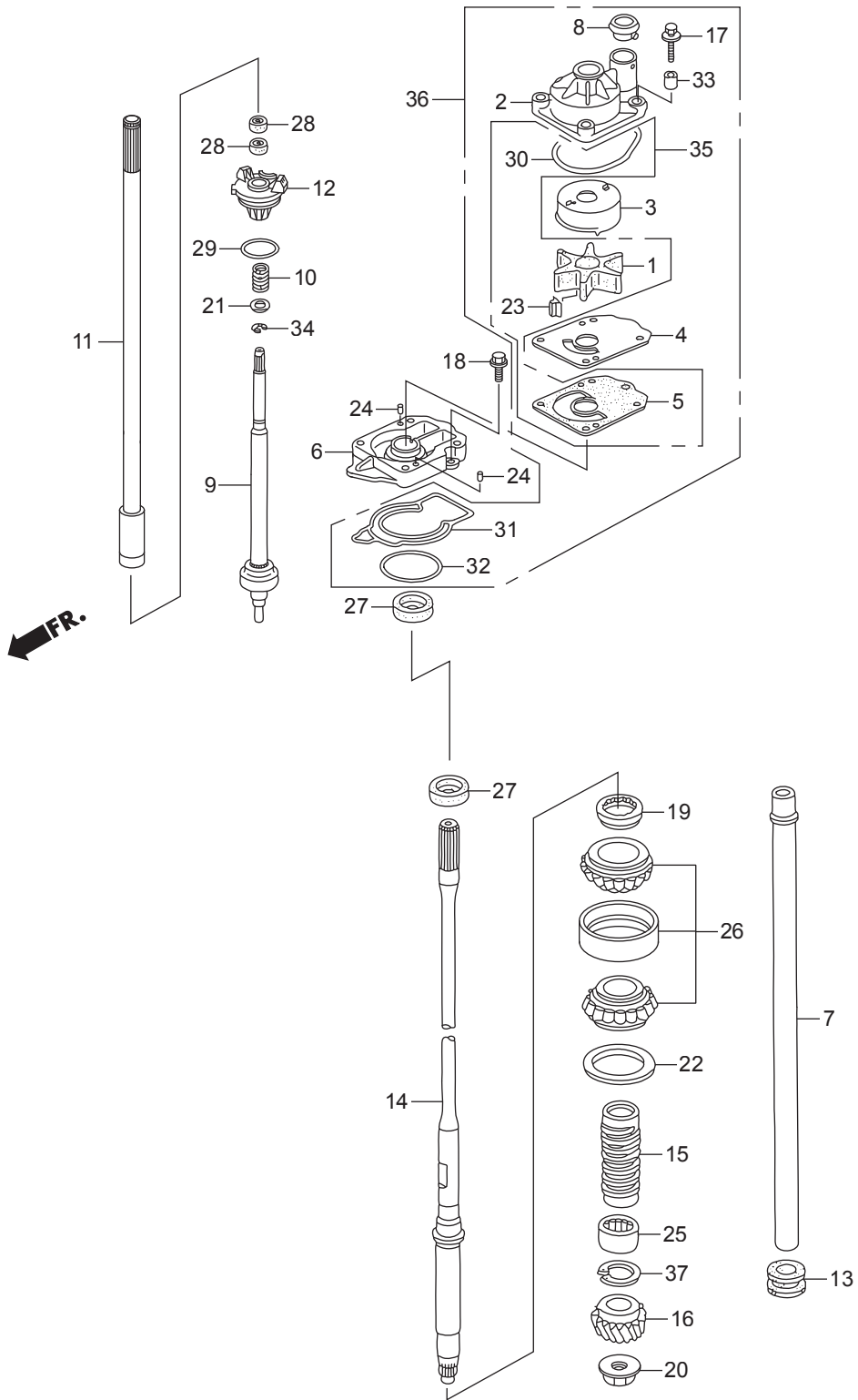

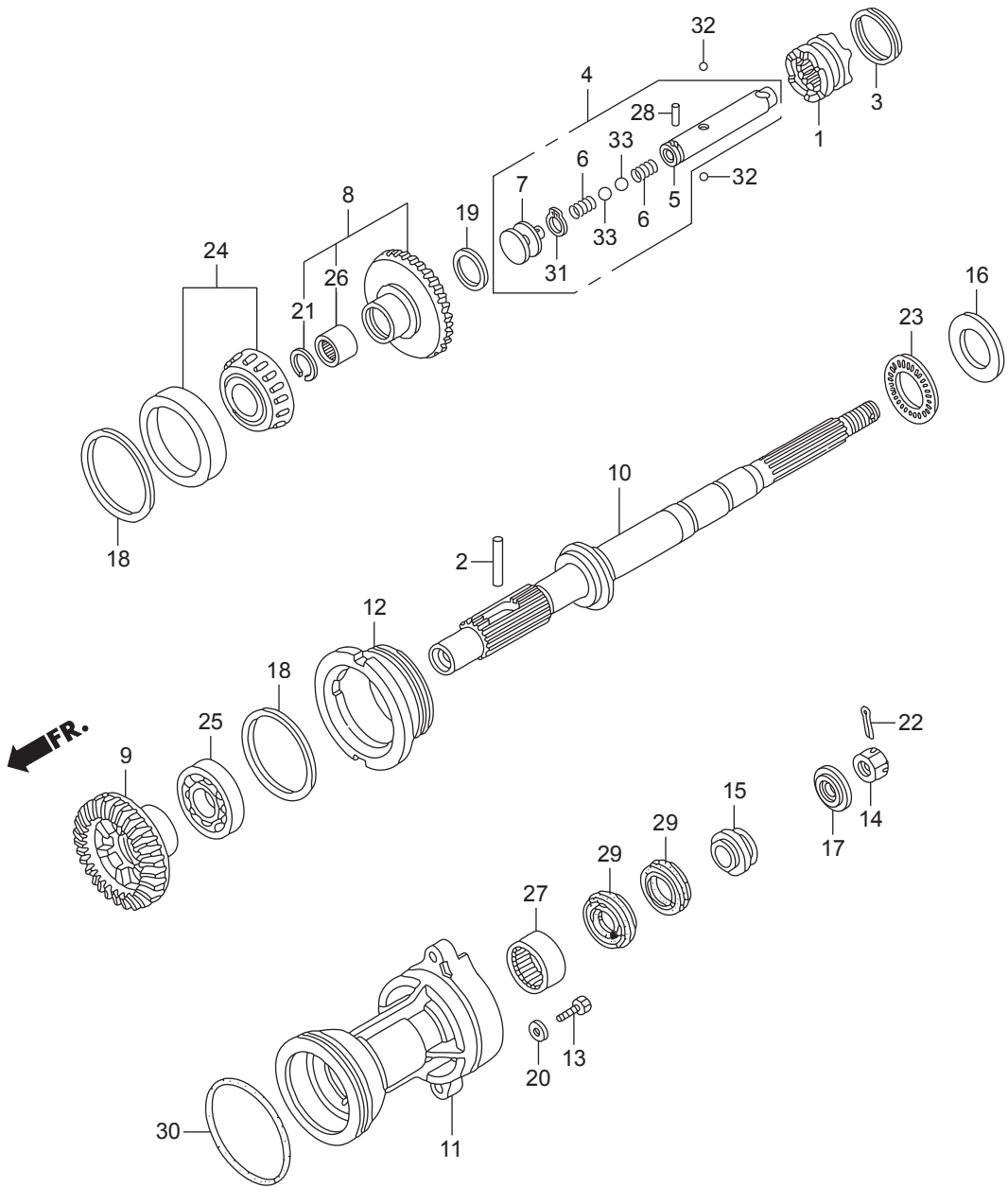

Ref.No.	Part No.	Description	Q' ty	Remarks	
			BFT250A		
F-5	1	HZX2-24101-C00	SHIFTER, CLUTCH	1	LA,XA,XXA
F-5	2	HZY3-24102-000	PIN, SHIFTER, 8X50	1	LA,XA,XXA
F-5	3	HZY3-24103-000	RING, CROSS PIN	1	LA,XA,XXA
F-5	4	HZY3-24113-A01	SLIDER COMP., SHIFT	1	LA,XA,XXA
F-5	5	HZY3-24122-A01	SLIDER, SHIFT	1	LA,XA,XXA
F-5	6	HZY3-24123-000	SPRING, SHIFT	2	LA,XA,XXA
F-5	7	HZY3-24124-310	PLATE, SHIFT	1	LA,XA,XXA
F-5	8	HZX2-41140-C00	GEAR COMP., BEVEL(FORWARD)	1	(24T) LA,XA,XXA
F-5	9	HZX2-41151-C00	GEAR, BEVEL(REVERSE)(24T)	1	LA,XA,XXA
F-5	10	HZX2-41161-C00	SHAFT, PROPELLER	1	LA,XA,XXA
F-5	11	HZX2-41201-C00ZC	HOLDER, PROPELLER SHAFT	1	*T107*BAY BLUE LA,XA,XXA
F-5	12	HZX2-41202-C00	HOLDER, BEARING	1	LA,XA,XXA
F-5	13	HZY3-90123-000	BOLT, HEX., 12X45	2	LA,XA,XXA
F-5	14	HZW1-90301-B00	NUT, CASTLE, 18MM	1	LA,XA,XXA,XXCA
F-5	15	HZY3-90506-000	WASHER, PROPELLER THRUST	1	LA,XA
F-5	15	HZX2-90506-C00	WASHER, PROPELLER THRUST	1	LA,XA #6000072~ XXA,XXCA
F-5	16	HZW5-90509-711	WASHER, THRUST BEARING	1	LA,XA,XXA
F-5	17	HZY3-90512-000	WASHER, PROPELLER	1	LA,XA
F-5	17	HZX2-90512-C00	WASHER, PROPELLER	1	LA,XA #6000072~ XXA,XXCA
F-5	18	HZX2-90528-C00	SHIM A, BEVEL(0.10)	2	LA,XA,XXA
F-5	18	HZX2-90529-C00	SHIM B, BEVEL(0.15)	2	LA,XA,XXA
F-5	18	HZX2-90530-C00	SHIM C, BEVEL(0.30)	2	LA,XA,XXA
F-5	18	HZX2-90531-C00	SHIM D, BEVEL(0.50)	2	LA,XA,XXA
F-5	19	HZY3-90548-000	SHIM A, THRUST(2.75)	1	LA,XA,XXA
F-5	19	HZY3-90549-000	SHIM B, THRUST(2.80)	1	LA,XA,XXA
F-5	19	HZY3-90550-000	SHIM C, THRUST(2.85)	1	LA,XA,XXA
F-5	19	HZY3-90551-000	SHIM D, THRUST(2.90)	1	LA,XA,XXA

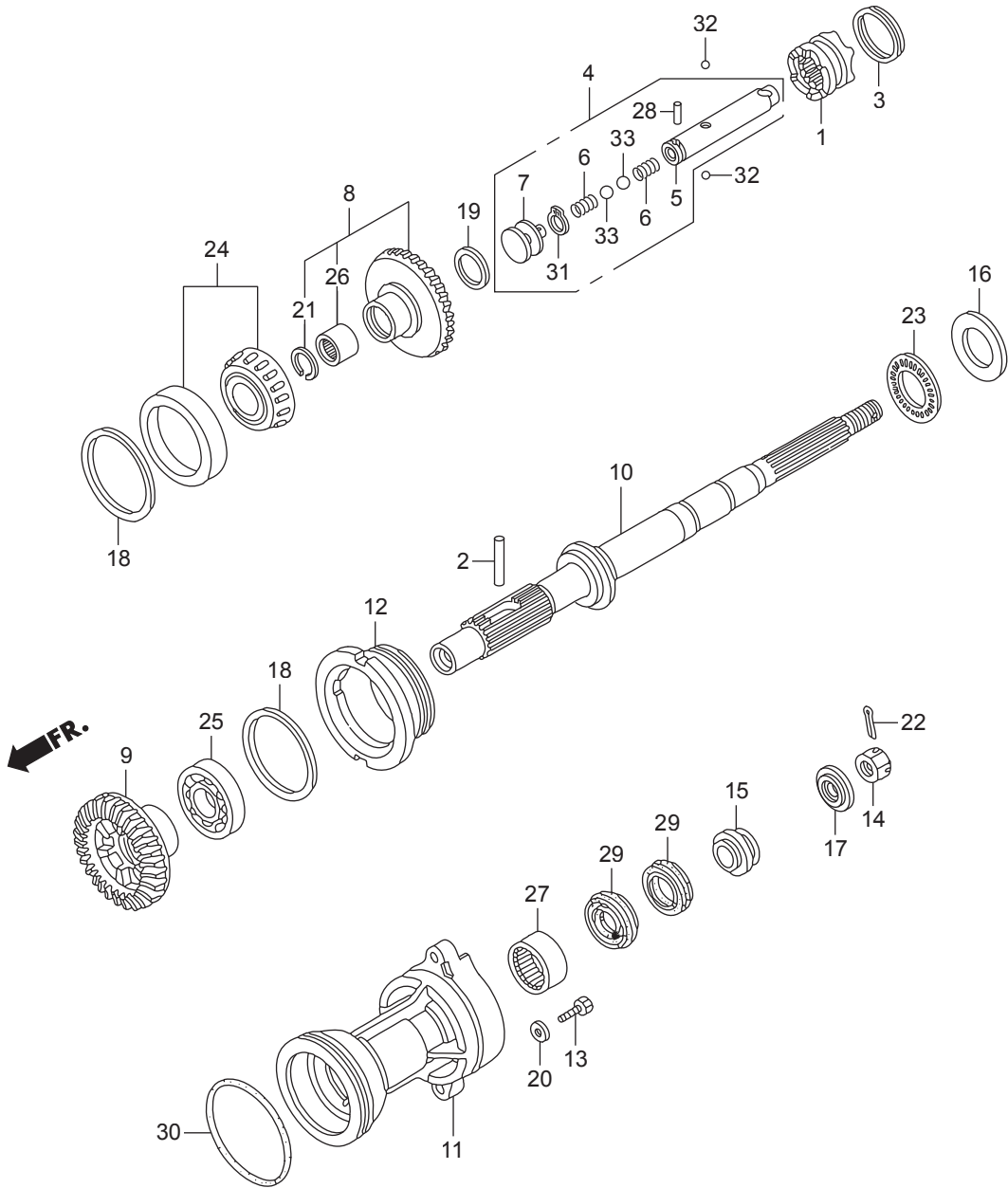

Ref.No.	Part No.	Description	Q' ty	Remarks	
			BFT250A		
F-5	19	HZY3-90552-000	SHIM E, THRUST(2.95)	1	LA,XA,XXA
F-5	19	HZY3-90553-000	SHIM F, THRUST(3.00)	1	LA,XA,XXA
F-5	19	HZY3-90554-000	SHIM G, THRUST(3.05)	1	LA,XA,XXA
F-5	19	HZY3-90555-000	SHIM H, THRUST(3.10)	1	LA,XA,XXA
F-5	19	HZY3-90556-000	SHIM I, THRUST(2.70)	1	LA,XA,XXA
F-5	19	HZY3-90557-000	SHIM J, THRUST(2.65)	1	LA,XA,XXA
F-5	19	HZY3-90558-000	SHIM K, THRUST(2.60)	1	LA,XA,XXA
F-5	19	HZY3-90559-000	SHIM L, THRUST(2.55)	1	LA,XA,XXA
F-5	19	HZY3-90560-000	SHIM M, THRUST(2.50)	1	LA,XA,XXA
F-5	20	HZV5-90559-000	WASHER, PLAIN, 12MM	2	LA,XA,XXA
F-5	21	HZX2-90651-C00	RING, SETTING(39)	1	LA,XA,XXA
F-5	22	HZW1-90758-B00	PIN, SPLIT, 4.0	1	LA,XA,XXA,XXCA
F-5	23	HPT2-91005-N01	BEARING, THRUST(F)	1	LA,XA,XXA
F-5	24	HZX2-91051-C01	BEARING, TAPER ROLLER,	1	60X100X30 LA,XA,XXA
F-5	25	HZX2-91055-C01	BEARING, RADIAL BALL,	1	55X100X21 LA,XA,XXA
F-5	26	HZY3-91056-711	BEARING, NEEDLE, 28X39X30	1	LA,XA,XXA
F-5	27	HZY3-91057-003	BEARING, NEEDLE, 32X42X30	1	LA,XA,XXA
F-5	28	HZY3-91151-000	ROLLER, 3X13.8	1	LA,XA,XXA
F-5	29	HZZ3-91252-003	SEAL, WATER, 30X45X7	2	LA,XA,XXA
F-5	30	HZX2-91351-C00	O-RING, 121X3.1	1	LA,XA,XXA
F-5	31	HCO-94510-15000	CIRCLIP, EXTERNAL, 15MM	1	LA,XA,XXA
F-5	32	HCO-96211-07000	BALL, STEEL, #7(7/32)	2	LA,XA,XXA
F-5	33	HCO-96211-12000	BALL, STEEL, #12(3/8)	2	LA,XA,XXA

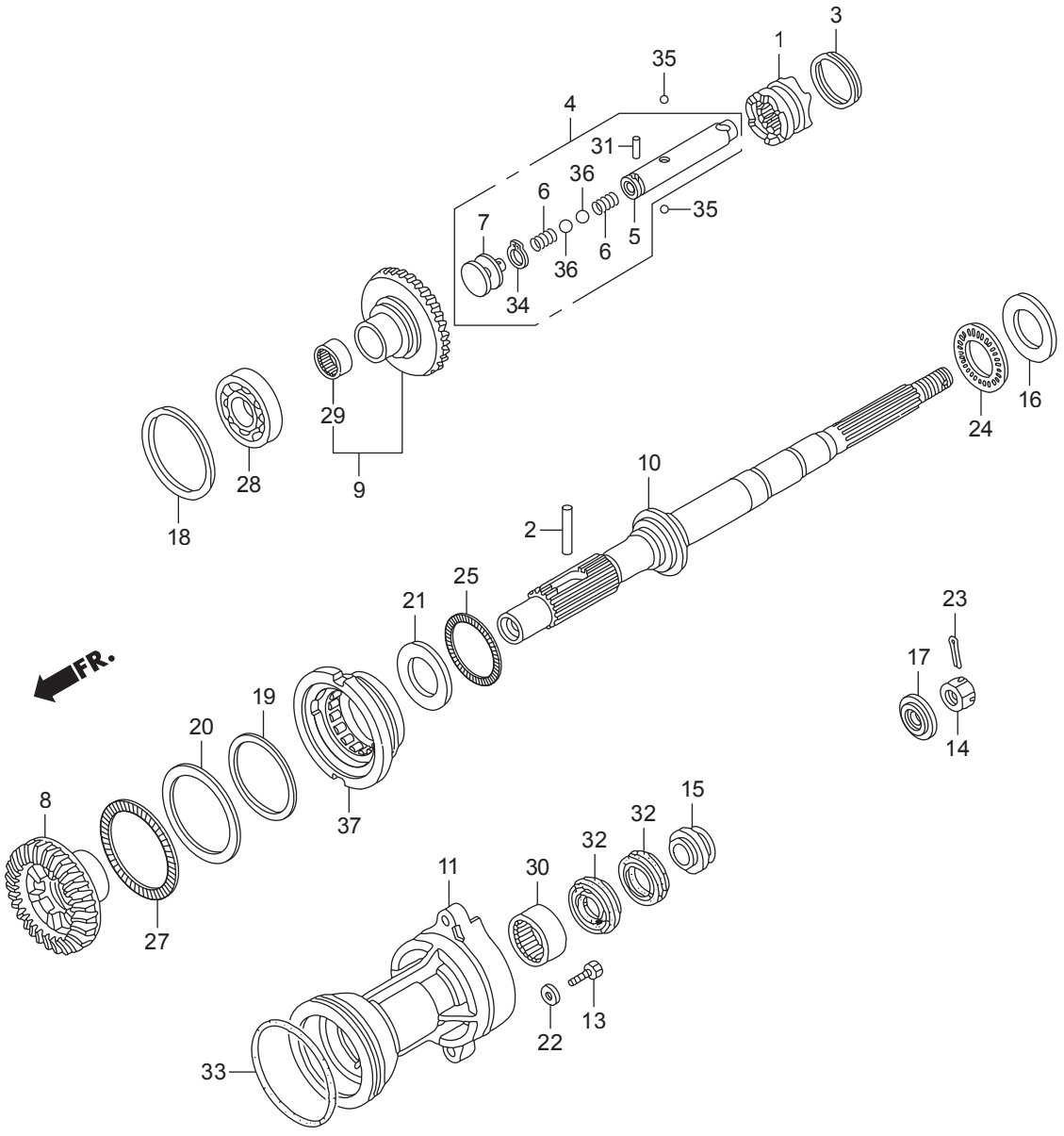

Ref.No.	Part No.	Description	Q' ty	Remarks	
			BFT250A		
F-5-1	1	HZX2-24101-C00	SHIFTER, CLUTCH	1	XCA,XXCA
F-5-1	2	HZY3-24102-000	PIN, SHIFTER, 8X50	1	XCA,XXCA
F-5-1	3	HZY3-24103-000	RING, CROSS PIN	1	XCA,XXCA
F-5-1	4	HZY3-24113-A01	SLIDER COMP., SHIFT	1	XCA,XXCA
F-5-1	5	HZY3-24122-A01	SLIDER, SHIFT	1	XCA,XXCA
F-5-1	6	HZY3-24123-000	SPRING, SHIFT	2	XCA,XXCA
F-5-1	7	HZY3-24124-310	PLATE, SHIFT	1	XCA,XXCA
F-5-1	8	HZX2-41141-E00	GEAR, BEVEL(FORWARD)(24T)	1	(COUNTER ROTATION) XCA,XXCA
F-5-1	9	HZX2-41150-E00	GEAR COMP., BEVEL(REVERSE)	1	(24T)(COUNTER ROTATION) XCA,XXCA
F-5-1	10	HZX2-41161-E00	SHAFT, PROPELLER	1	XCA,XXCA
F-5-1	11	HZX2-41201-C00ZC	HOLDER, PROPELLER SHAFT	1	*T107*BAY BLUE XCA,XXCA
F-5-1	13	HZY3-90123-000	BOLT, HEX., 12X45	2	XCA,XXCA
F-5-1	14	HZW1-90301-B00	NUT, CASTLE, 18MM	1	XCA
F-5-1	15	HZY3-90506-000	WASHER, PROPELLER THRUST	1	XCA
F-5-1	15	HZX2-90506-C00	WASHER, PROPELLER THRUST	1	XCA #7000011~
F-5-1	16	HZW5-90509-711	WASHER, THRUST BEARING	1	XCA,XXCA
F-5-1	17	HZY3-90512-000	WASHER, PROPELLER	1	XCA
F-5-1	17	HZX2-90512-C00	WASHER, PROPELLER	1	XCA #7000011~
F-5-1	18	HZX2-90528-C00	SHIM A, BEVEL(0.10)	1	XCA,XXCA
F-5-1	18	HZX2-90529-C00	SHIM B, BEVEL(0.15)	1	XCA,XXCA
F-5-1	18	HZX2-90530-C00	SHIM C, BEVEL(0.30)	1	XCA,XXCA
F-5-1	18	HZX2-90531-C00	SHIM D, BEVEL(0.50)	1	XCA,XXCA
F-5-1	19	HZX2-90528-E00	SHIM A, BEVEL(0.10)	1	(COUNTER ROTATION) XCA,XXCA
F-5-1	19	HZX2-90529-E00	SHIM B, BEVEL(0.15)	1	(COUNTER ROTATION) XCA,XXCA
F-5-1	19	HZX2-90530-E00	SHIM C, BEVEL(0.30)	1	(COUNTER ROTATION) XCA,XXCA
F-5-1	19	HZX2-90531-E00	SHIM D, BEVEL(0.50)	1	(COUNTER ROTATION) XCA,XXCA
F-5-1	20	HZX2-90541-E01	WASHER, THRUST, 85X110X2	1	XCA,XXCA
F-5-1	21	HZX2-90542-E01	WASHER, THRUST, 48X74X3	1	(COUNTER ROTATION) XCA,XXCA
F-5-1	22	HZV5-90559-000	WASHER, PLAIN, 12MM	2	XCA,XXCA

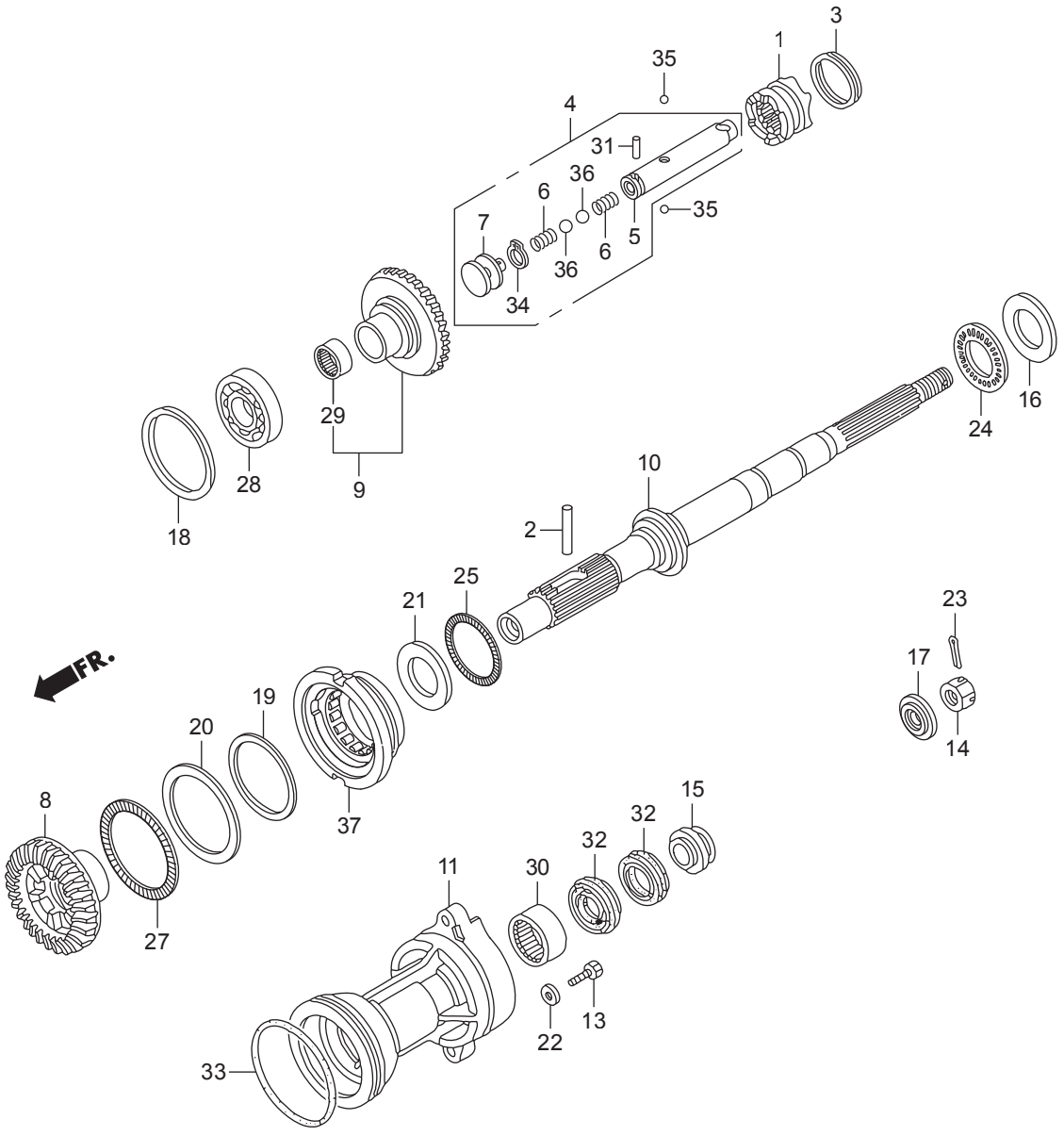

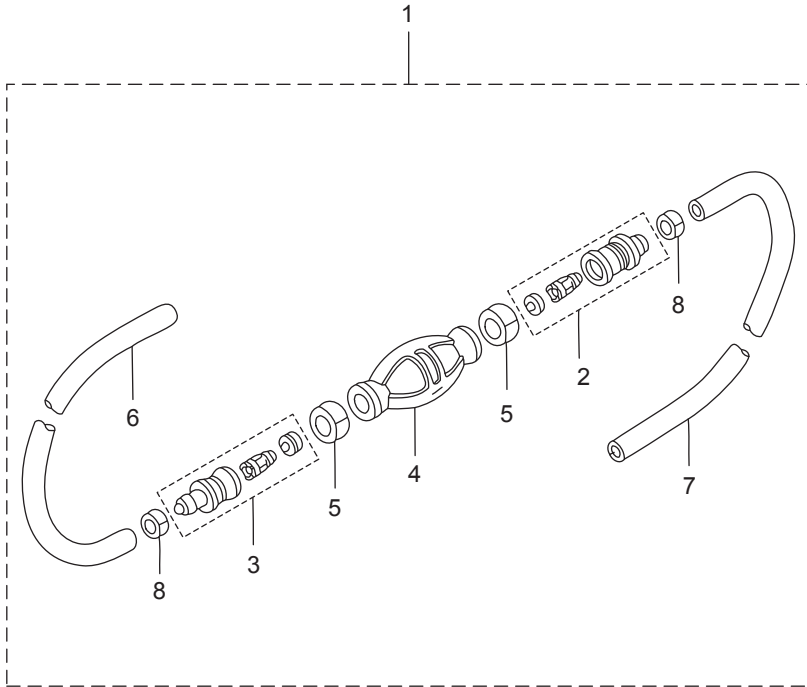

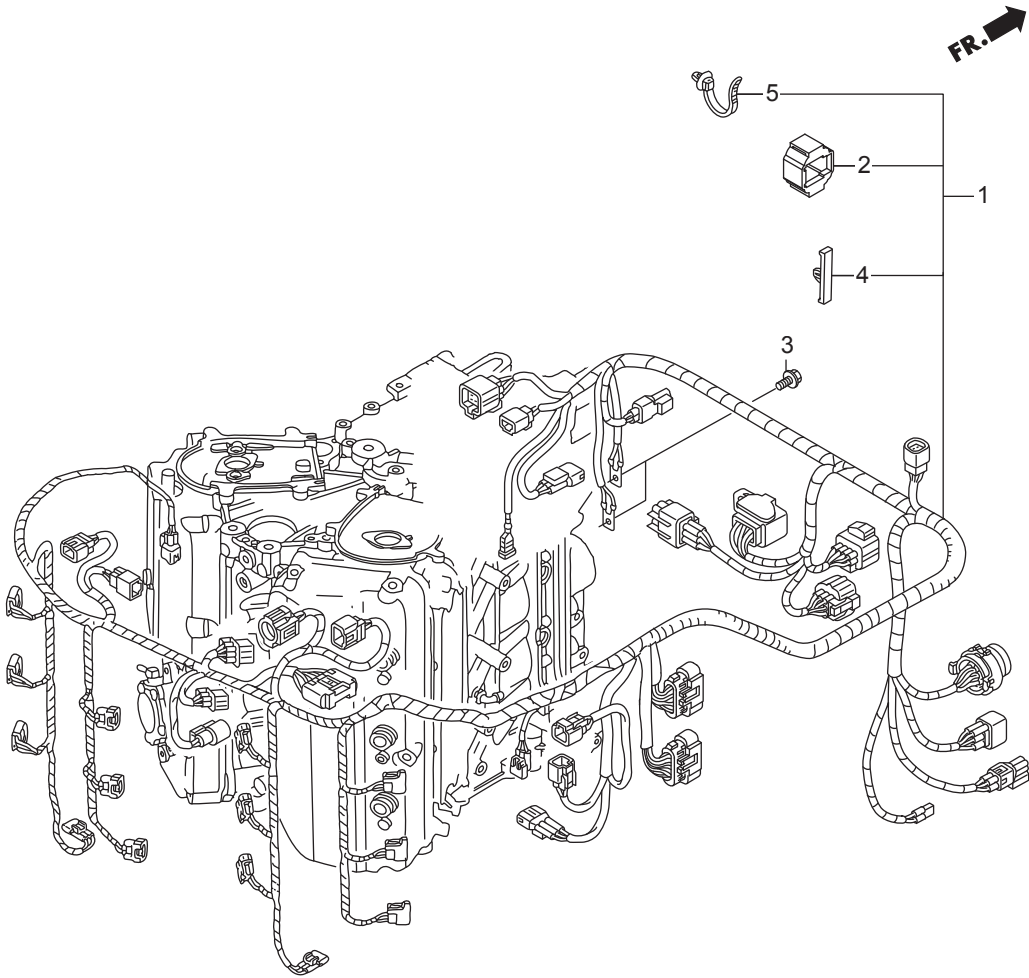

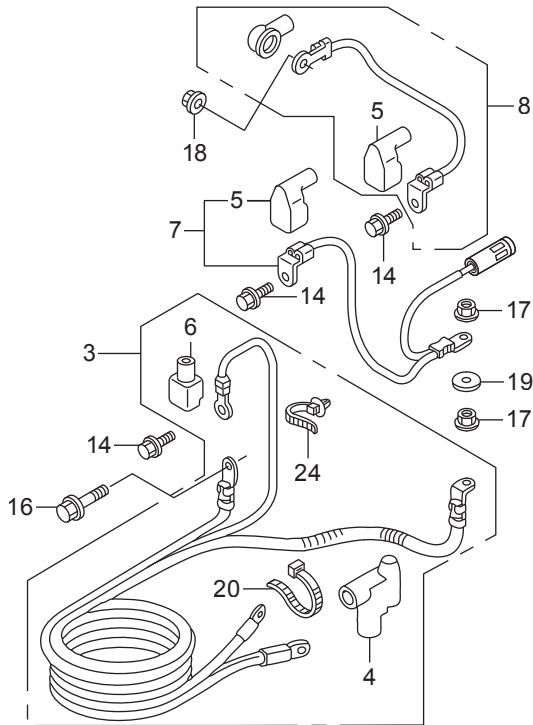
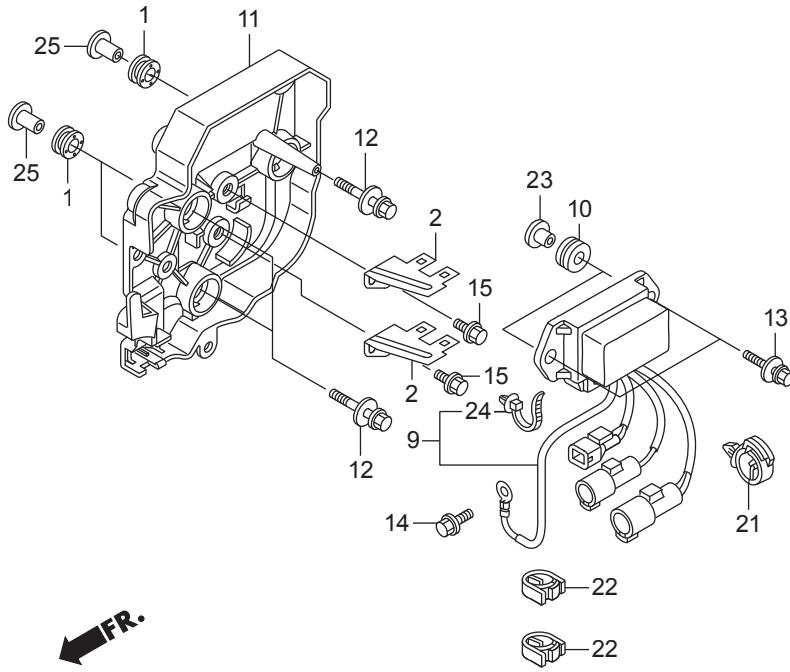

Ref.No.	Part No.	Description	Q' ty	Remarks	
			BFT250A		
F-7-10	1	HZY9-30419-003	GROMMET, ELECTRONIC PARTS CASE	3	
F-7-10	2	HZY9-32103-000	BRACKET C, COUPLER	2	
F-7-10	3	HZX2-32410-000	CABLE ASSY., STARTER	1	
F-7-10	4	HZY3-32411-003	COVER, STARTER TERMINAL	1	
F-7-10	5	HZX2-32414-300	COVER B, TERMINAL(L)	2	
F-7-10	6	HZY6-32414-640	COVER B, TERMINAL	1	
F-7-10	7	HZX2-32415-000	CABLE ASSY., POWER TILT RELAY	1	
F-7-10	8	HZX2-32435-000	CORD, A.C. GENERATOR	1	
F-7-10	9	HZX2-38550-003	RELAY ASSY., POWER TILT	1	
F-7-10	10	HZW1-38551-000	GROMMET, RELAY	2	
F-7-10	11	HZX2-38552-000	CASE, POWER TILT RELAY	1	
F-7-10	12	HZW2-90003-000	BOLT-WASHER, 6X27(CT200)	3	
F-7-10	13	HZW1-90013-000	BOLT-WASHER, 6X25	2	
F-7-10	14	HZW9-90013-000	BOLT, FLANGE, 6X12	4	
F-7-10	15	HZW9-90014-000	BOLT, FLANGE, 6X10	2	
F-7-10	16	HZY3-90107-000	BOLT, FLANGE, 8X18	1	
F-7-10	17	HZW1-90203-000	NUT-WASHER, 8MM	2	
F-7-10	18	HZY3-90304-000	NUT-WASHER, 6MM	1	
F-7-10	19	HZY3-90405-000	WASHER, PLAIN, 8MM	1	
F-7-10	20	HSB2-90620-003	BAND, WIRE HARNESS	1	LA,XA #~6000051
F-7-10	20	HSB2-90620-003	BAND, WIRE HARNESS	1	XCA #~7000006
F-7-10	20	HKV6-90651-003	BAND, WIRE, 165MM(BLACK)	1	LA,XA #6000052~ XCA #7000007~ XXA,XXCA
F-7-10	21	H763-90681-A01	CLIP, WIRE HARNESS	1	
F-7-10	22	HZX2-90683-003	CLIP, WIRE HARNESS	2	
F-7-10	23	HZZ5-91501-000	COLLAR, MOUNTING(6MM)	2	
F-7-10	24	HS0A-91541-003	CLIP, HARNESS BAND(BLACK)	4	(145MM)
F-7-10	25	HZV5-91553-010	COLLAR, C.D.I. UNIT CASE	3	

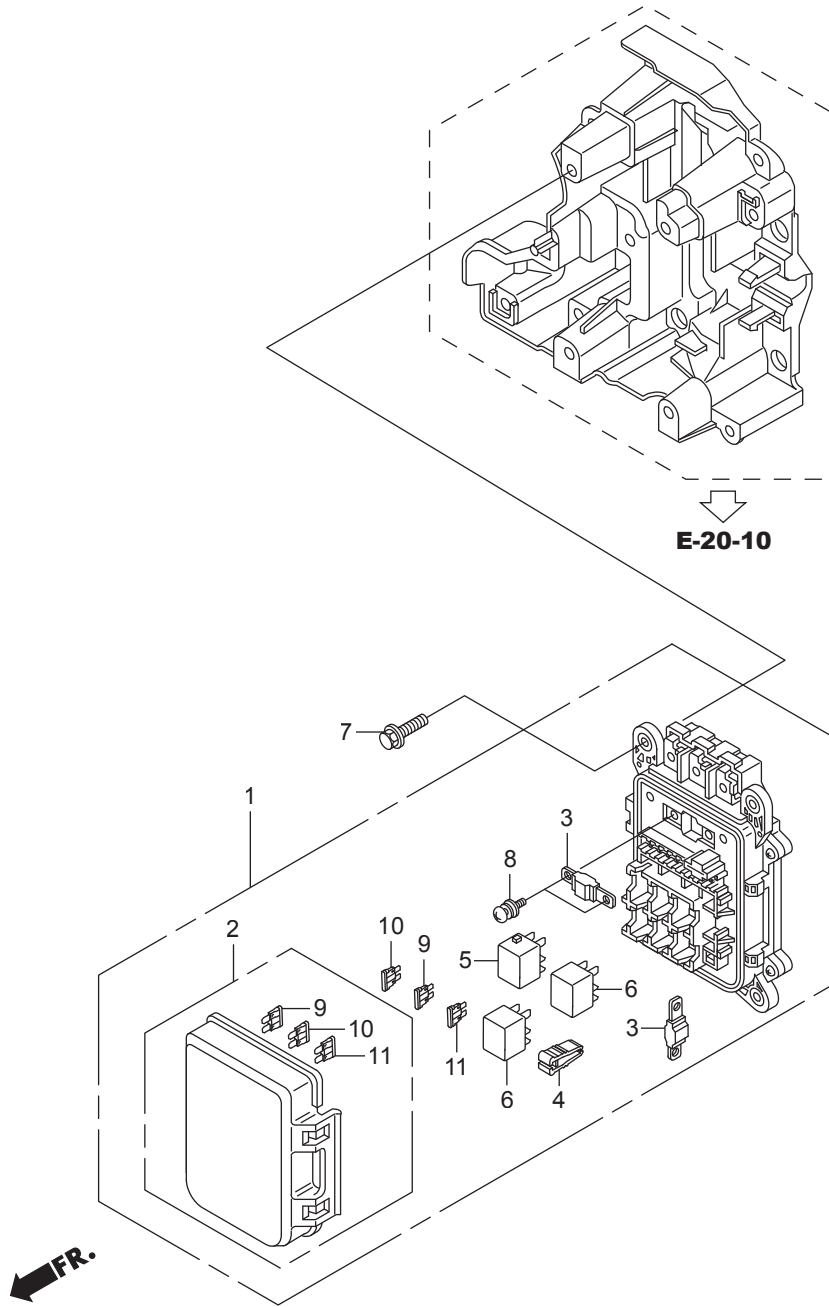

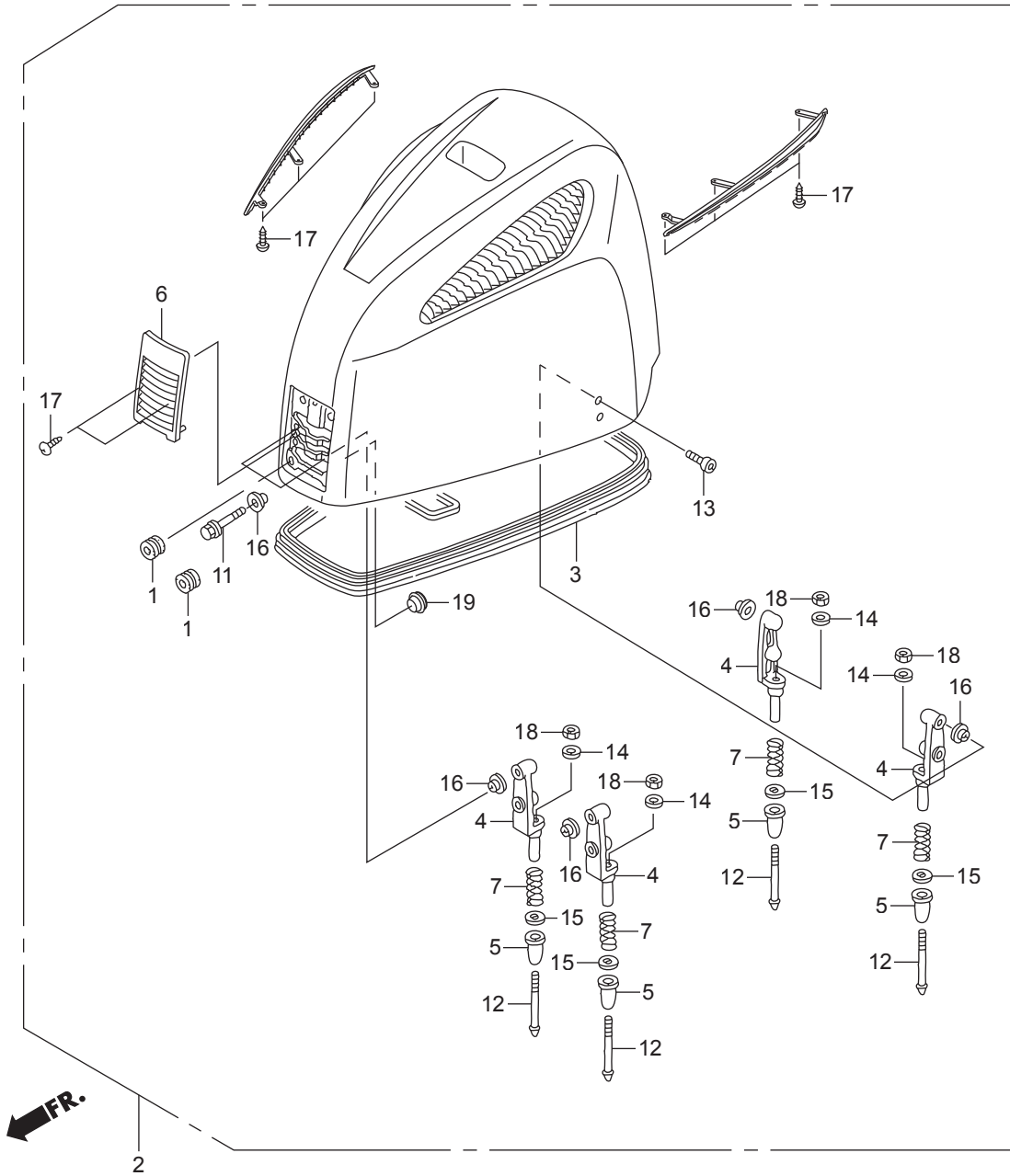

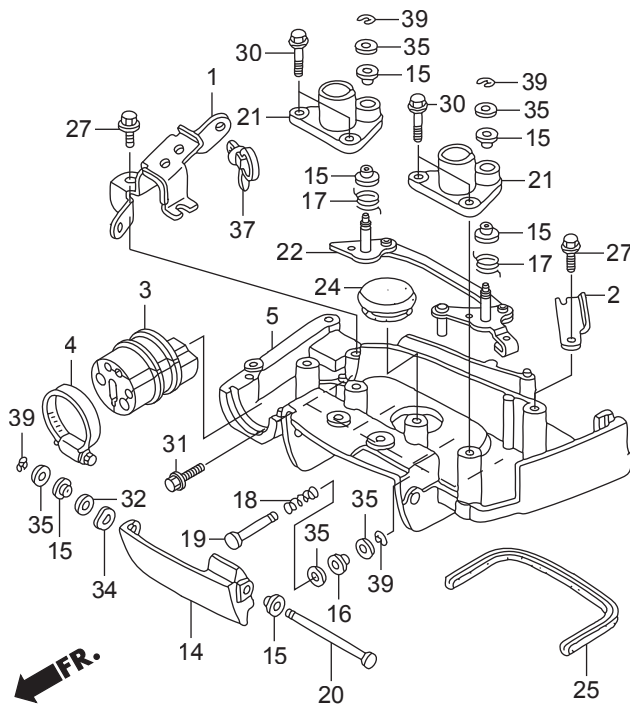
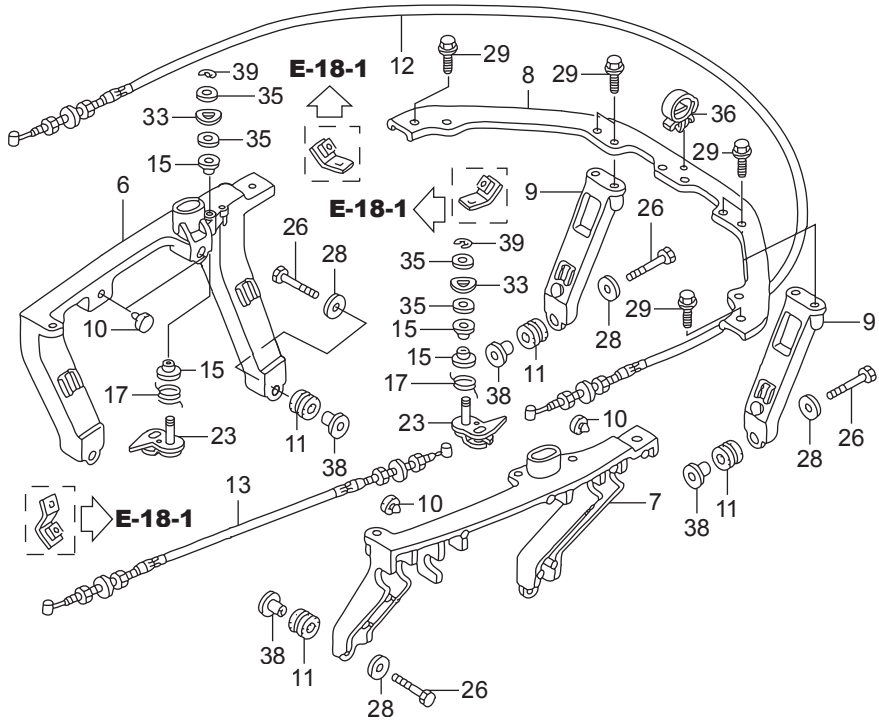

Ref.No.	Part No.	Description	Q' ty	Remarks	
			BFT250A		
F-8-10	1	HZY3-32419-A00	BRACKET, CABLE	1	
F-8-10	2	HZY3-32421-000	PLATE, STARTER CABLE	1	
F-8-10	3	HZY3-40105-C01	GROMMET A, UNDER CASE	1	
F-8-10	4	HZY3-40119-003	BAND, UNDER CASE GROMMET	1	
F-8-10	5	HZY3-40154-000ZA	BRACKET, FR. COVER	1	*NH8* DARK GRAY
F-8-10	6	HZY3-40155-000	BRACKET, R. SIDE COVER	1	
F-8-10	7	HZY3-40157-000	BRACKET, L. SIDE COVER	1	
F-8-10	8	HZY3-40158-000	BRACKET A, RR. COVER	1	
F-8-10	9	HZY3-40159-000	BRACKET B, RR. COVER	2	
F-8-10	10	H196-47117-000	RUBBER, STOPPER	4	
F-8-10	11	H121-51640-730	RUBBER, FR. CARRIER CUSHION	6	
F-8-10	12	HZY3-60180-C01	CABLE COMP. A, COVER LOCK	1	
F-8-10	13	HZY3-60185-C01	CABLE COMP. B, COVER LOCK	1	
F-8-10	14	HZY3-63201-000ZC	LEVER, COVER LOCK	1	*T107*BAY BLUE
F-8-10	15	HZY3-63205-000	BUSH A, COVER LOCK	10	
F-8-10	16	HZY3-63208-000	BUSH B, COVER LOCK	1	
F-8-10	17	HZY3-63212-000	SPRING, COVER LOCK HOOK	4	
F-8-10	18	HZY3-63223-000	SPRING, LOCK LEVER RETURN	1	
F-8-10	19	HZY3-63224-000	SHAFT, COVER OPEN	1	
F-8-10	20	HZY3-63225-000	SHAFT, FR. LOCK	1	
F-8-10	21	HZY3-63226-000	HOLDER, STRIKER	2	
F-8-10	22	HZY3-63230-C00	LOCK ASSY., FR.	1	
F-8-10	23	HZX2-63260-C00	LOCK COMP., SIDE	2	
F-8-10	24	HZC0-63515-700	CAP, L. SIDE COVER	1	
F-8-10	25	HZY3-63729-003	SEAL D, UNDER COVER	1	
F-8-10	26	HZV5-90009-000	BOLT, HEX., 8X35	6	
F-8-10	27	HZY3-90021-000	BOLT, FLANGE, 6X14	2	
F-8-10	28	HML0-90101-720	WASHER, PLAIN, 8MM	6	
F-8-10	29	HZW9-90102-000	BOLT, FLANGE, 6X12	6	

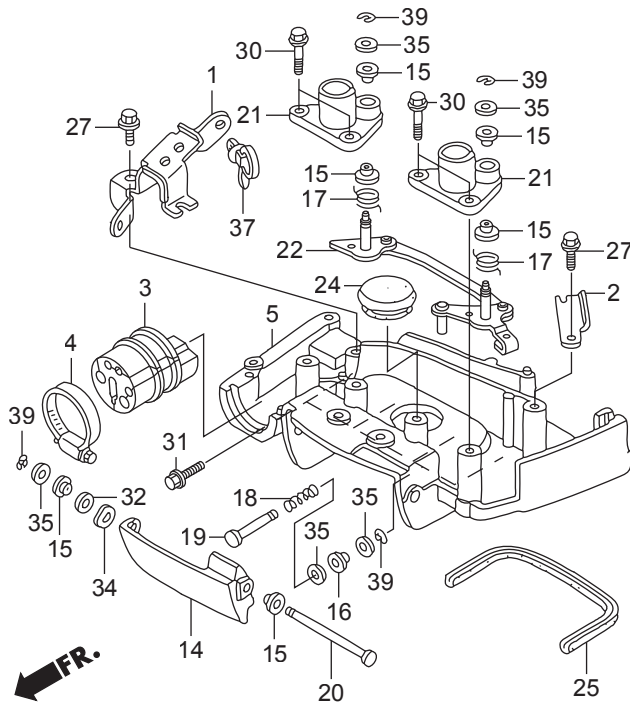
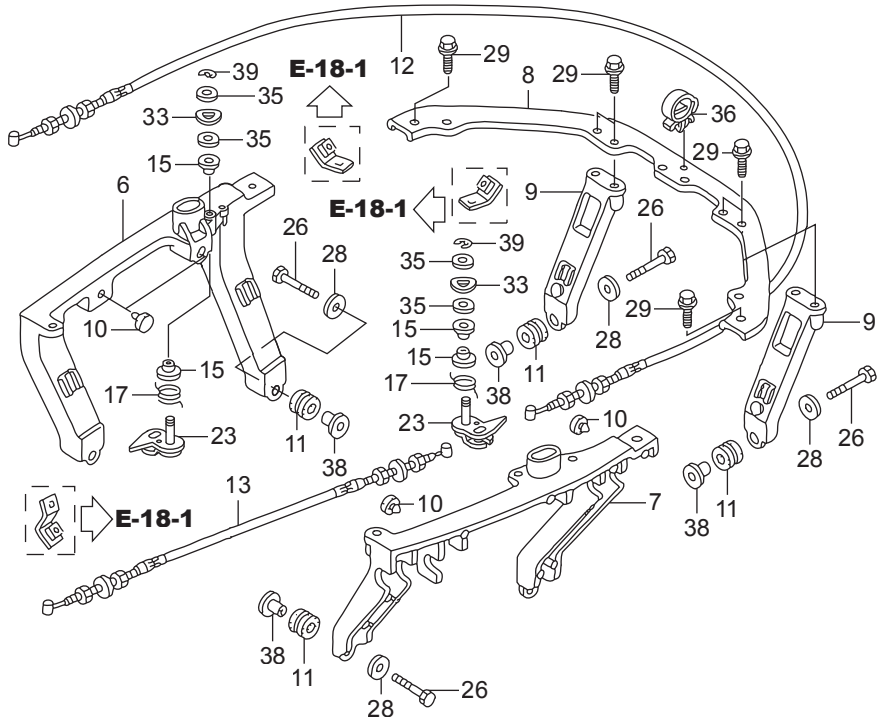

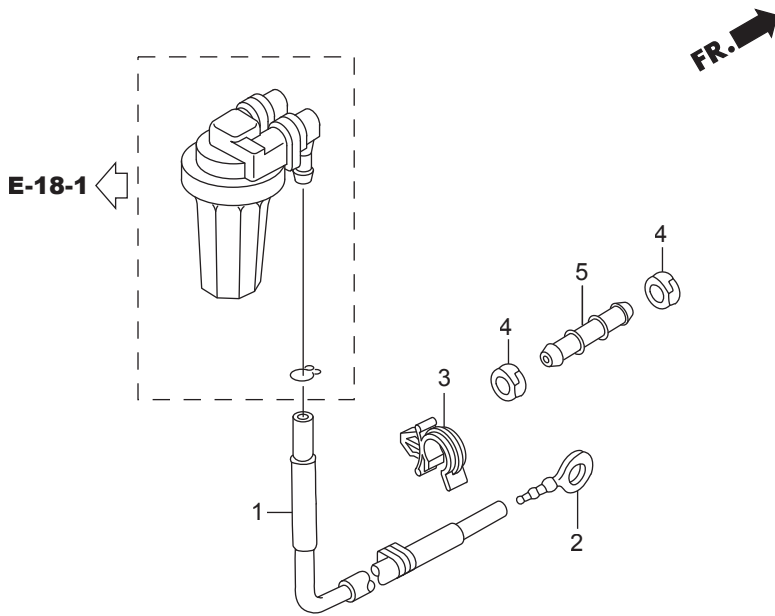

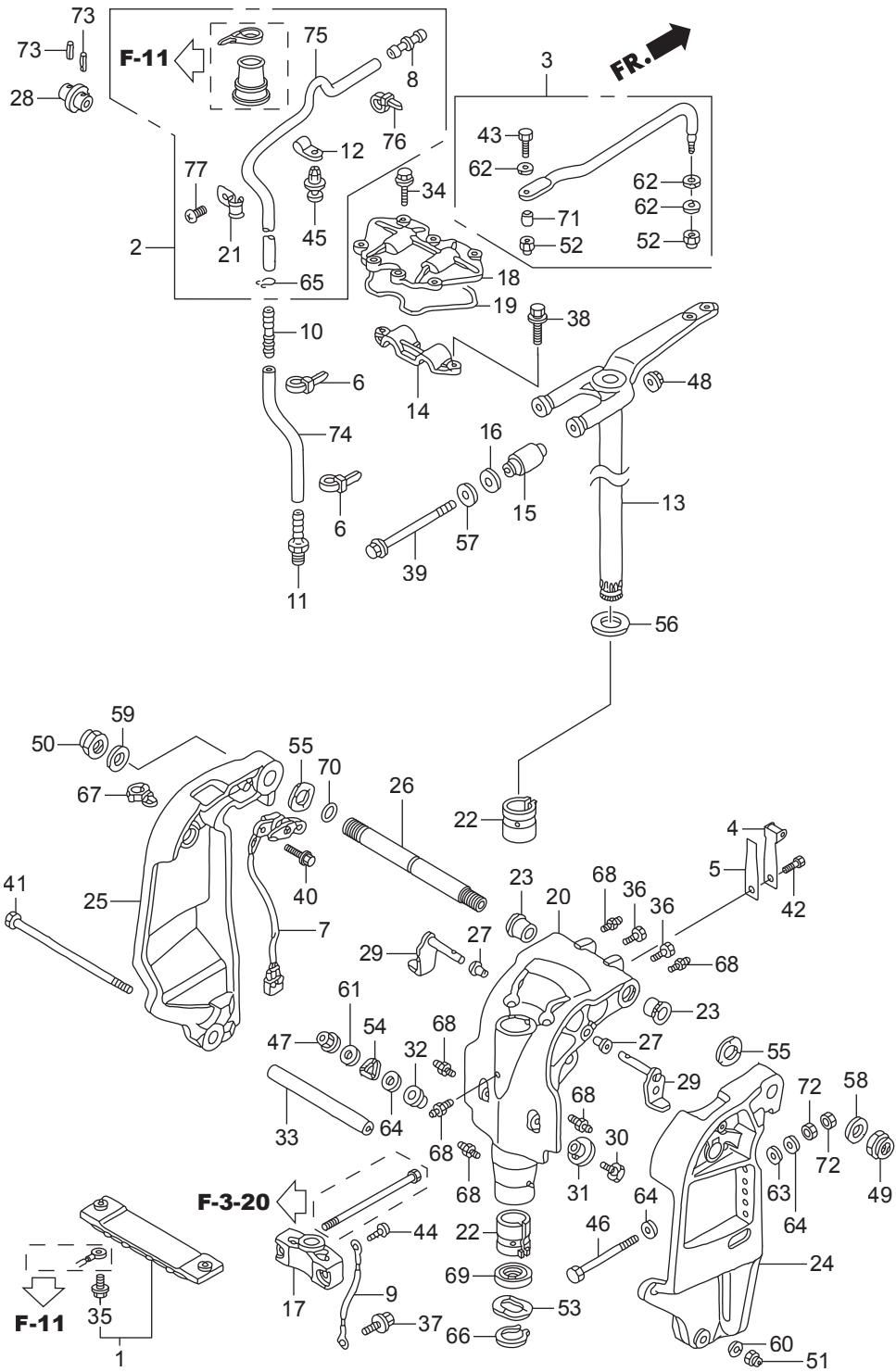

Ref.No.	Part No.	Description	Q' ty	Remarks	
			BFT250A		
F-10	1	HZW1-06411-020	METAL KIT, ANODE	1	
F-10	2	HZY3-06412-000	TUBE KIT, SPEED SENSOR	1	
F-10	3	HZY3-06532-U00	ROD KIT, STEERING	1	
F-10	4	HZV1-24210-010	SPRING COMP., CLICK	1	
F-10	5	HZV4-24221-010	SPRING, CLICK ASSIST	1	
F-10	6	HKM3-32161-003	BAND, WIRE	2	
F-10	7	HZY3-35660-003	SENSOR ASSY., TRIM ANGLE	1	
F-10	8	H663-38562-920	JOINT B, WASHER TUBE(MITSUBA)	1	
F-10	9	HZY3-40219-013	WIRE, LEAD(1.5X116MM)	1	
F-10	10	HZV5-41171-000	END, NIPPLE	1	
F-10	11	HZV5-41172-000	NIPPLE, SENSOR	1	
F-10	12	HZY3-41179-A00	CLAMPER, SENSOR TUBE	2	
F-10	13	HZY3-50100-A01	FRAME COMP., MOUNTING(L)	1	LA
F-10	13	HZY3-50100-A11	FRAME COMP., MOUNTING(XL)	1	XA,XCA,XXA,XXCA
F-10	14	HZY3-50109-000	HOUSING, UPPER MOUNTING	1	
F-10	15	HZY3-50151-000	MOUNT COMP., UPPER RUBBER	2	
F-10	16	HZY3-50153-000	RUBBER, UPPER MOUNT STOPPER	2	
F-10	17	HZY3-50161-000ZD	HOUSING, LOWER CENTER MOUNTING	1	*T107*BAY BLUE LA
F-10	17	HZY3-50161-610	HOUSING, LOWER CENTER MOUNTING	1	(XL) XA,XCA,XXA,XXCA
F-10	18	HZY3-50166-000	COVER, UPPER MOUNT	1	
F-10	19	HZY3-50168-000	SEAL, UPPER MOUNT COVER	1	
F-10	20	HZY3-50201-C01ZD	CASE, SWIVEL	1	*T107*BAY BLUE LA
F-10	20	HZY3-50201-C11ZC	CASE, SWIVEL	1	*T107*BAY BLUE XA,XCA,XXA,XXCA
F-10	21	HZY3-50209-A00	CLAMP, TUBE	2	
F-10	22	HZY3-50211-000	LINER, SWIVEL CASE	2	
F-10	23	HZY3-50214-000	BUSH, SWIVEL CASE	2	
F-10	24	HZY3-50301-030ZC	BRACKET, R. STERN	1	*T107*BAY BLUE
F-10	25	HZY3-50311-020ZC	BRACKET, L. STERN	1	*T107*BAY BLUE
F-10	26	HZY3-50381-000	SHAFT, TILTING	1	

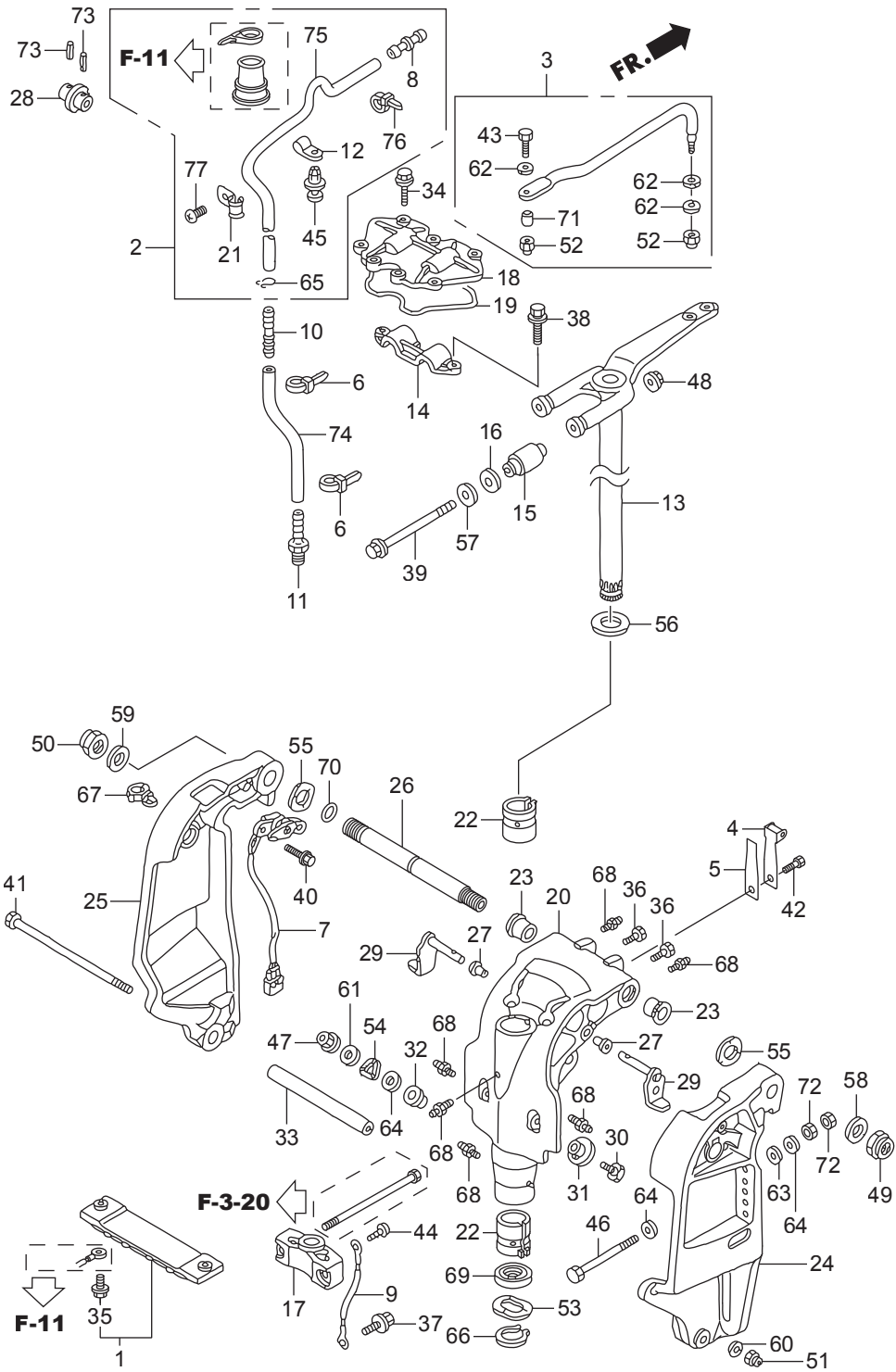

Ref.No.	Part No.	Description	Q' ty	Remarks	
			BFT250A		
F-10	27	HZY3-50522-000	BUSH, TILT ARM	2	
F-10	28	HZY3-50527-000	BRACKET, TILTING	1	
F-10	29	HZY3-50529-000	STOPPER, TILT	2	
F-10	30	HZY3-56516-A00	RECEIVER, THRUST	2	
F-10	31	HZY3-56518-A00	BUSH A, THRUST RECEIVE	2	
F-10	32	HZY3-56519-A00	BUSH B, THRUST RECEIVE	2	
F-10	33	HZW1-56539-000	COLLAR, LOWER CYLINDER	1	LA,XA #~6000063
F-10	33	HZW1-56539-000	COLLAR, LOWER CYLINDER	1	XCA #~7000008
F-10	33	HZZ0-56539-C00	COLLAR, LOWER CYLINDER	1	LA,XA #6000064~ XCA #7000009~ XXA,XXCA
F-10	34	HZW9-90005-000	BOLT, FLANGE, 6X20	7	
F-10	35	HZW9-90009-000	BOLT, FLANGE, 6X23	2	
F-10	36	HZW1-90102-000	BOLT, 1/4-28UNF	2	
F-10	37	HZW9-90103-010	BOLT, FLANGE, 6X12	1	
F-10	38	HZY6-90103-000	BOLT-WASHER, 10X32	3	
F-10	39	HZY3-90104-010	BOLT, HEX., 12X200	2	
F-10	40	HZW9-90105-000	BOLT, FLANGE, 6X20	2	
F-10	41	HZW1-90108-000	BOLT, HEX., 10X235	1	
F-10	42	H881-90110-000	BOLT, HEX., 6X14	1	
F-10	43	HZY3-90117-000	BOLT, 3/8-24UNF	1	
F-10	44	HZV5-90119-000	SCREW, PAN, 6X8	1	
F-10	45	HZV5-90127-003	SCREW, RIVET, 5X10	2	
F-10	46	HZX2-90129-000	BOLT, HEX., 12X130	6	
F-10	47	HZY1-90205-000	NUT, SELF-LOCK, 6MM	2	
F-10	48	HZW5-90302-003	NUT, FLANGE, 12MM	2	
F-10	49	HZV5-90304-013	NUT, SELF-LOCK(7/8-14UNF)	1	
F-10	50	HZW1-90304-013	NUT, SELF-LOCK(25X2.0)	1	
F-10	51	HZW4-90306-003	NUT, FLANGE, 10MM	1	

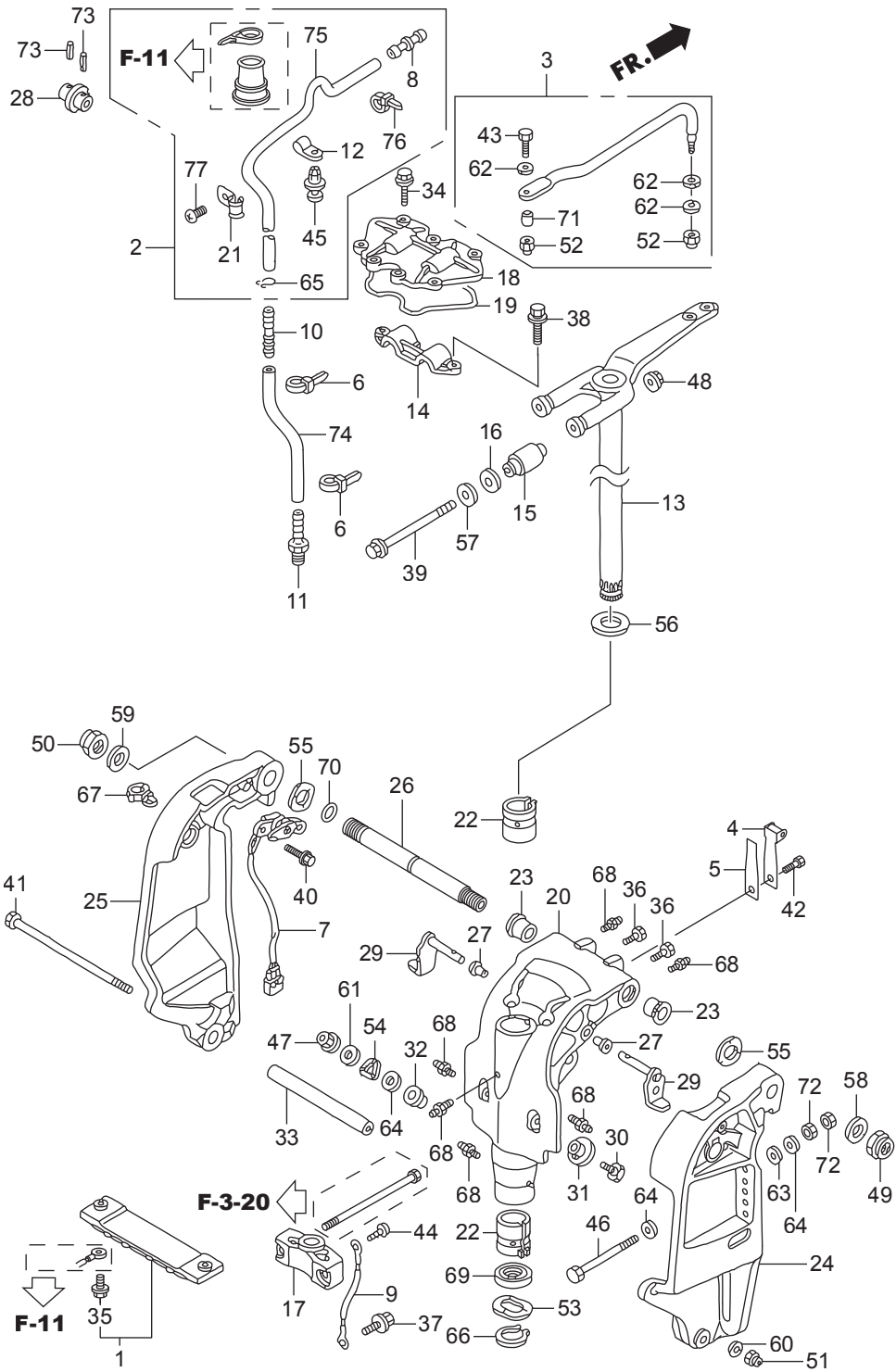

Ref.No.	Part No.	Description	Q' ty	Remarks	
			BFT250A		
F-10	52	HZV5-90307-003	NUT, SELF-LOCK(3/8-24UNF)	2	
F-10	53	HZV5-90501-000	WASHER, WAVE, 40MM	1	
F-10	54	HZY3-90501-A00	WASHER, WAVE, 12MM	2	
F-10	55	HZV5-90502-000	WASHER, WAVE, 26MM	2	
F-10	56	HZV5-90504-000	WASHER, THRUST, 34MM	1	
F-10	57	HZY3-90504-A00	WASHER, UPPER MOUNTING STOPPER	2	LA,XA,XCA
F-10	57	HZY3-90504-A00	WASHER, UPPER MOUNTING STOPPER	2	LA,XA #6000072~
F-10	57	HZX2-90504-C00	WASHER, UPPER MOUNTING STOPPER	2	XCA #7000011~ XXA,XXCA
F-10	58	HZY3-90509-000	WASHER, 7/8INCH	1	
F-10	59	HZY3-90510-000	WASHER, 25MM	1	
F-10	60	H921-90511-000	WASHER, PLAIN, 10MM	1	
F-10	61	HZV4-90512-000	WASHER, PLAIN, 6MM	2	
F-10	62	HZV4-90514-000	WASHER, 10MM	3	
F-10	63	HZV5-90552-000	WASHER, PLAIN, 12MM	6	
F-10	64	HZV5-90559-000	WASHER, PLAIN, 12MM	14	
F-10	65	H921-90602-000	CLIP, TUBE(B8)	1	
F-10	66	HZV5-90651-000	CIRCLIP, EXTERNAL, 39MM	1	
F-10	67	H763-90681-A01	CLIP, WIRE HARNESS	1	
F-10	68	HZV7-90951-010	NIPPLE, GREASE	6	
F-10	69	HZV5-91256-003	OIL SEAL, 39.5X52X6(ARAI)	1	
F-10	70	HZV5-91352-000	O-RING, 15.54X2.26	1	
F-10	71	HZY3-91560-000	COLLAR, STEERING ROD	1	
F-10	72	HCO-94001-12490-0S	NUT, HEX., 12MM	12	
F-10	73	HCO-94305-30203	PIN, SPRING, 3X20	2	
F-10	74	HCO-95005-50200-30	TUBE, 5X200	1	(HCO-95005-50001-30M)
F-10	75	HCO-95005-50950-30	TUBE, 5X950	1	(HCO-95005-50001-30M)
F-10	76	HKM3-32161-003	BAND, WIRE	1	
F-10	77	HZV5-90119-000	SCREW, PAN, 6X8	2	

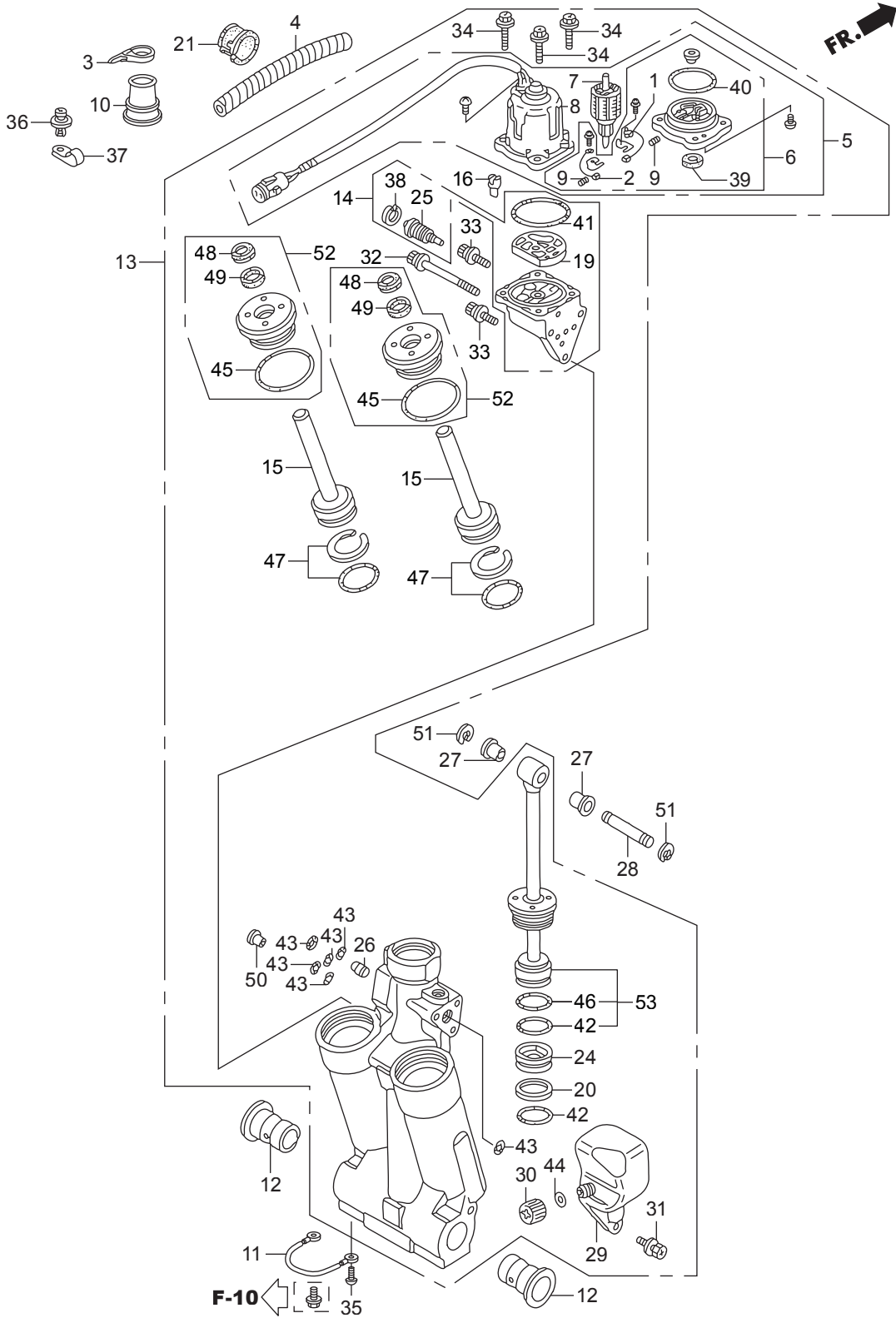

Ref.No.	Part No.	Description	Q' ty	Remarks	
			BFT250A		
F-11	1	HZX2-30280-003	BREAKER ASSY.	1	
F-11	2	HZX2-31106-003	BRUSH ASSY.	1	
F-11	3	HMG9-35701-950	BAND(BLACK 3.5X140)	1	
F-11	4	HZW1-36104-003	TUBE, SPIRAL(12X14.6)	1	
F-11	5	HZX2-36120-013	MOTOR ASSY., POWER TILT	1	
F-11	6	HZX2-36122-003	BRACKET ASSY.	1	
F-11	7	HZY3-36123-013	ARMATURE COMP.	1	
F-11	8	HZX2-36129-003	YOKE ASSY.	1	
F-11	9	HZV5-36136-821	SPRING, MOTOR	2	
F-11	10	HZW1-40107-700	GROMMET, UNDER CASE(C)	2	
F-11	11	HZY3-40219-013	WIRE, LEAD(1.5X116MM)	1	
F-11	12	HZV5-50214-003	BUSH, SWIVEL CASE	2	
F-11	13	HZX2-56000-023	TRIM-TILT ASSY., POWER	1	
F-11	14	HZY3-56100-013	PUMP ASSY.	1	
F-11	15	HZW1-56110-701	ROD COMP., PISTON(B)	2	
F-11	16	HZW1-56113-701	JOINT, DRIVE	1	
F-11					
F-11	19	HZW1-56116-701	FILTER B	1	
F-11	20	HZV5-56117-821	RING, BACK UP	1	
F-11	21	HZV5-56118-820	BUSH, MOTOR CODE	1	
F-11					
F-11	24	HZW1-56130-702	PISTON COMP., FREE	1	
F-11	25	HZY3-56170-013	VALVE COMP., MANUAL	1	
F-11	26	HZW1-56180-701	VALVE COMP., RESERVOIR	1	
F-11	27	HZV5-56513-000	BUSH, LOWER CYLINDER	2	
F-11	28	HZY3-56532-000	PIN, UPPER CYLINDER	1	LA,XA,XCA
F-11	28	HZY3-56532-000	PIN, UPPER CYLINDER	1	LA,XA #6000072~
F-11	28	HZX2-56532-C00	PIN, UPPER CYLINDER	1	XCA #7000011~ XXA,XXCA

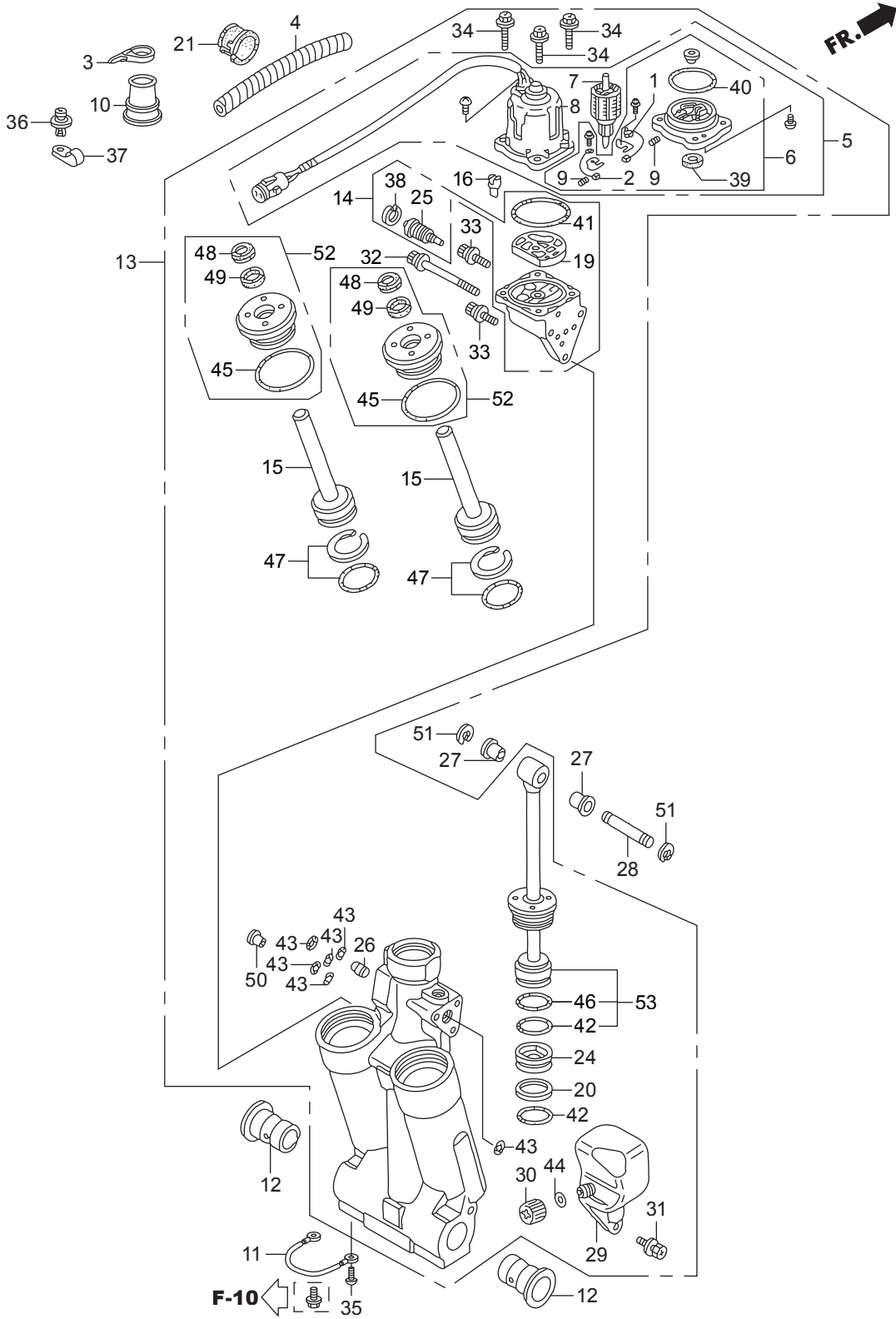

Ref.No.	Part No.	Description	Q' ty	Remarks	
			BFT250A		
F-11	29	HZW1-56851-703	TANK, OIL	1	
F-11	30	HZW1-56860-701	CAP COMP., OIL TANK	1	
F-11	31	HZW1-90113-702	BOLT, RECESSED	3	
F-11	32	HZW1-90114-702	BOLT, SOCKET(A)	1	
F-11	33	HZW1-90115-702	BOLT, SOCKET(B)	2	
F-11	34	HZW1-90116-702	BOLT, HEX.	4	
F-11	35	HZV5-90119-000	SCREW, PAN, 6X8	1	
F-11	36	HZV5-90127-003	SCREW, RIVET, 5X10	1	
F-11	37	HSB0-90602-003	CLIP, 10.7MM	1	
F-11	38	HZW1-90652-702	CIRCLIP, INTERNAL	1	
F-11	39	HZV5-91203-821	OIL SEAL	1	
F-11	40	HZW1-91207-013	O-RING, 2.0X70.5	1	
F-11	41	HZV5-91302-821	O-RING, 1.8X69.6	1	
F-11	42	HZV5-91316-821	O-RING, 3.5X38.7	2	
F-11	43	HZW1-91352-702	O-RING, 1.8X7.7	6	
F-11	44	HZW1-91353-703	O-RING, 1.9X11	1	
F-11	45	HZW1-91354-701	O-RING, 3.5X35.7	2	
F-11	46	HZW1-91355-701	O-RING, 3.5X41.7	1	
F-11	47	HZW1-91357-701	O-RING SET, 3.5X31.7	2	
F-11	48	HZW1-91358-701	SEAL, WATER	2	
F-11	49	HZW1-91361-701	PACKING	2	
F-11	50	HZW1-91557-701	COLLAR, ORIFICE	1	
F-11	51	HCO-94540-15029	E-RING, 15MM	2	
F-11	52	HZY9-56115-003	GUIDE COMP., ROD	2	
F-11	53	HZY3-56120-013	ROD COMP., PISTON	1	

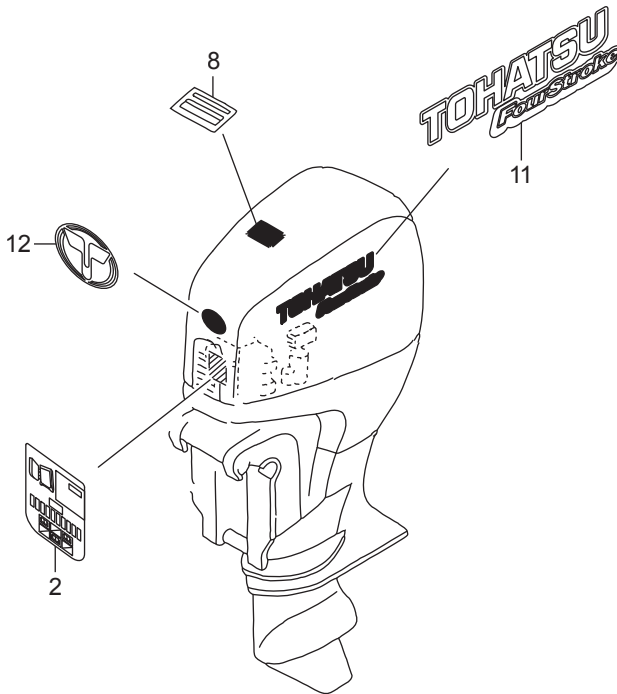
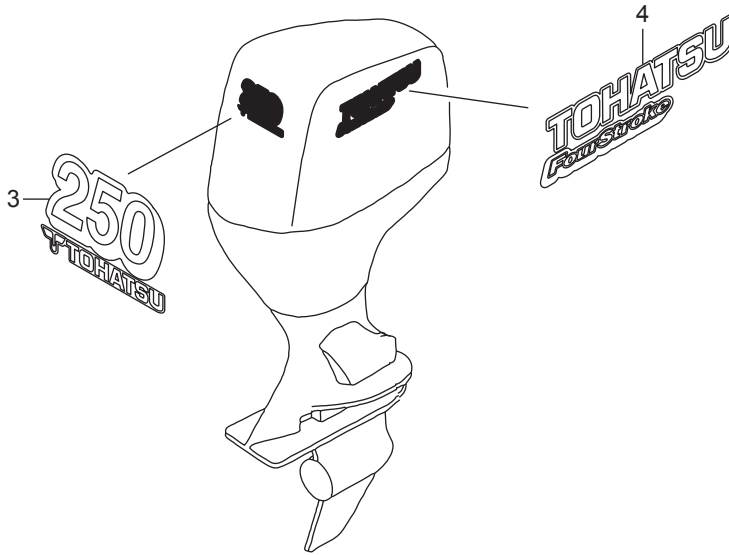

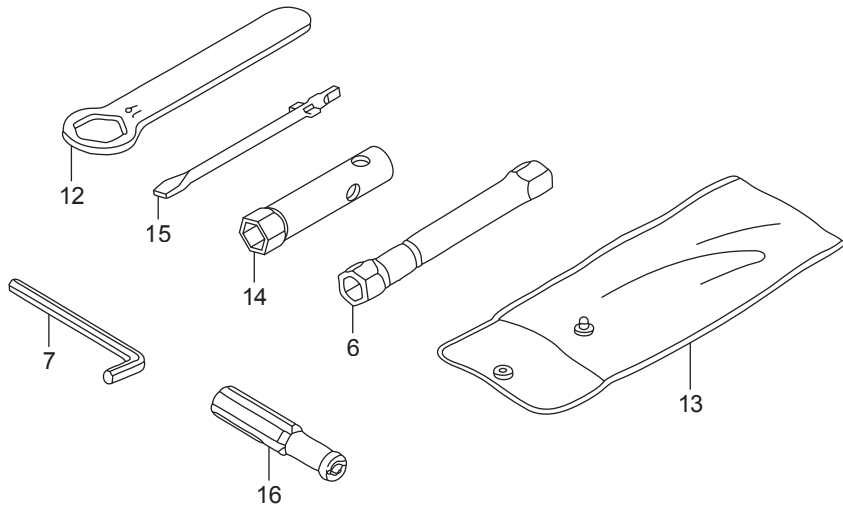

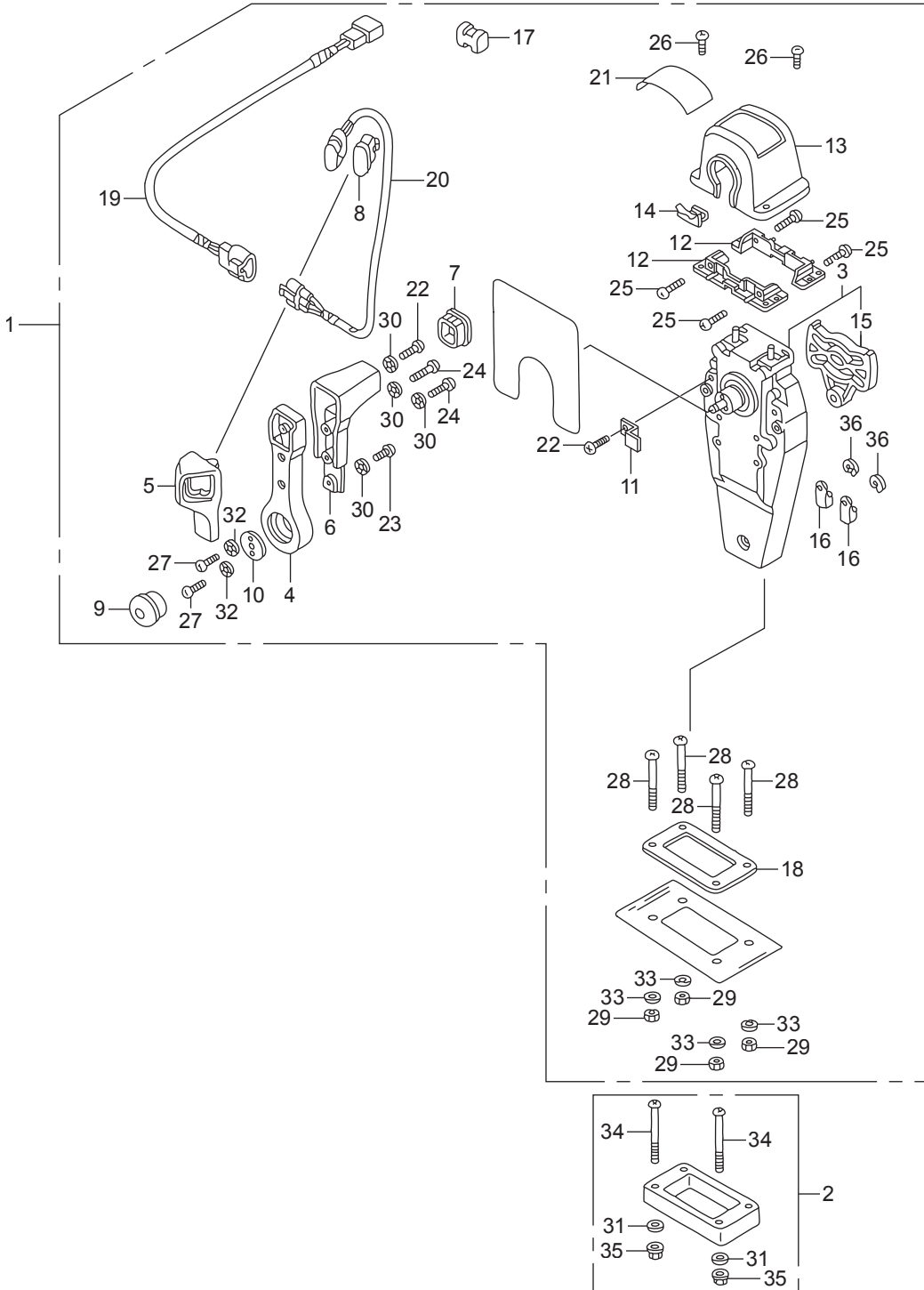

Ref.No.	Part No.	Description	Q' ty	Remarks	
			BFT250A		
FOP-1	1	HZZ3-06240-R30	BOX KIT, REMOTE CONTROL	1	(TOP MOUNT SINGLE)(R.)
FOP-1	2	HZW5-06241-U00	SPACER KIT, REMOTE CONTROL BOX	1	(TOP MOUNT SINGLE)
FOP-1	3	HZW5-24810-U01	HOUSING ASSY., L. INNER	1	(TOP MOUNT)
FOP-1	4	HZW5-24811-U01	HANDLE, REMOTE CONTROL	1	
FOP-1	5	HZW5-24812-U01	COVER, L. GRIP	1	
FOP-1	6	HZW5-24813-U01	GRIP, REMOTE CONTROL HANDLE	1	
FOP-1	7	HZW5-24814-U01	CAP, GRIP	1	
FOP-1	8	HZW5-24815-U01	CAP, SWITCH	1	
FOP-1	9	HZW5-24816-U01	BUTTON, THROTTLE	1	
FOP-1	10	HZW5-24817-U01	PLATE, HANDLE	1	
FOP-1	11	HZW5-24818-U01	PLATE, CABLE CLAMP	1	
FOP-1	12	HZW5-24819-U01	BRACKET, REMOTE CONTROL HOUSING	2	
FOP-1	13	HZZ3-24820-R11	HOUSING COMP., REMOTE CONTROL BOX	1	
FOP-1	14	HZW5-24825-U01	HOUSING, LEAD	1	
FOP-1	15	HZW5-24826-U01	PLATE, DWELL	1	
FOP-1	16	HZW5-24831-U01	TERMINAL, CABLE	2	
FOP-1	17	HZW5-24832-U01	SPACER, CABLE CLAMP	1	
FOP-1	18	HZW5-24834-U01	PACKING, SINGLE	1	
FOP-1	19	HZW7-32530-U00	SUB HARNESS ASSY., POWER TRIM-TILT(A)	1	
FOP-1	20	HZW5-35370-U02	SWITCH ASSY., POWER TRIM-TILT (A)	1	
FOP-1	21	HZZ3-87703-R81	MARK, REMOTE CONTROL(SINGLE)	1	
FOP-1	22	HZW5-90101-U00	SCREW, PAN, 5X16	2	
FOP-1	23	HZW5-90102-U00	SCREW, PAN, 5X10	1	
FOP-1	24	HZW5-90103-U01	SCREW, PAN, 5X20	2	
FOP-1	25	HZW5-90104-U00	SCREW, PAN, 5X18	4	
FOP-1	26	HZW5-90105-U01	SCREW, PAN, 4X10	2	
FOP-1	27	HZW5-90106-U00	SCREW, PAN, 6X18	2	
FOP-1	28	HZW5-90107-U00	SCREW, PAN, 5X40	4	
FOP-1	29	HZW5-90301-U00	NUT, HEX., 5MM	4	

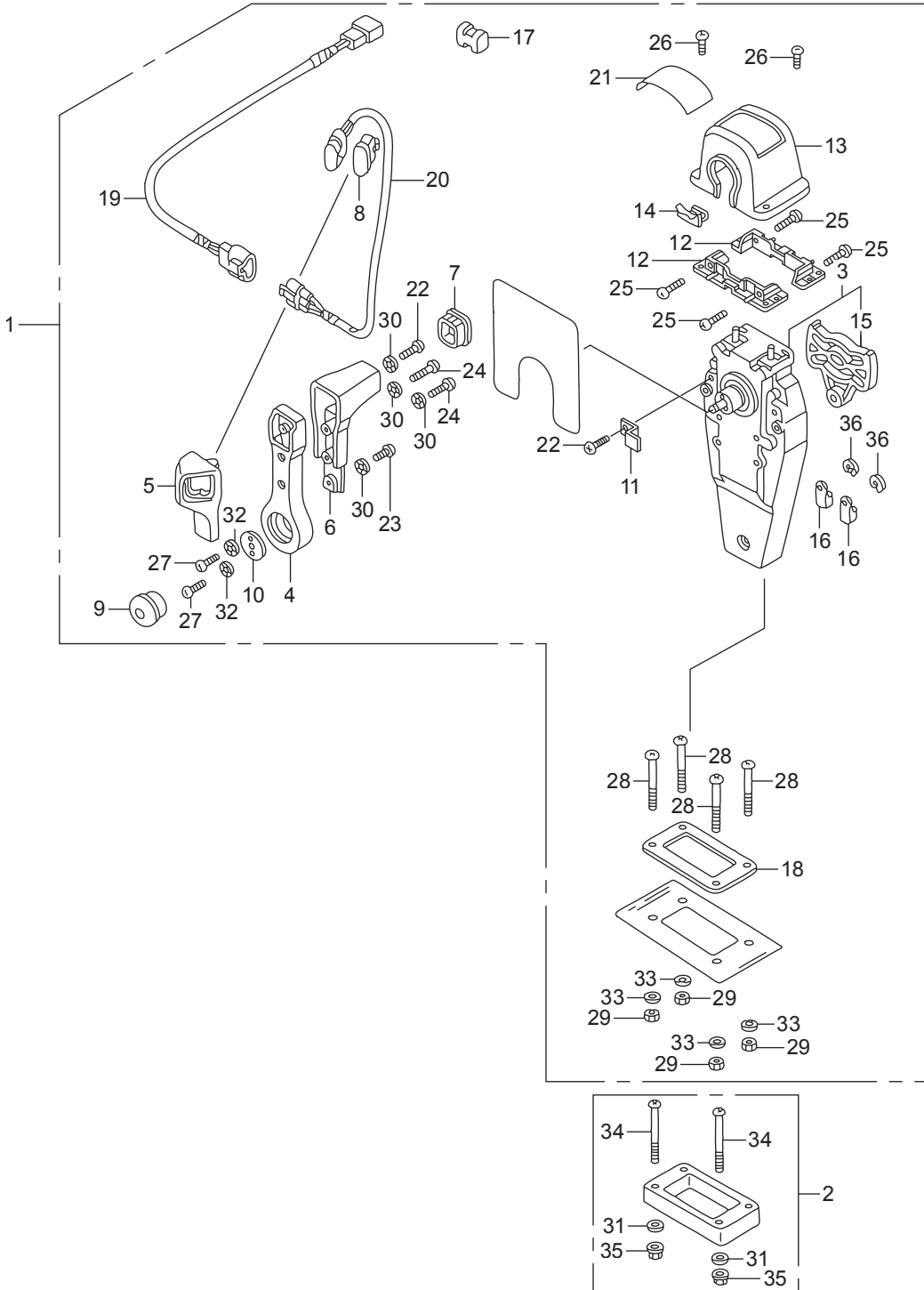

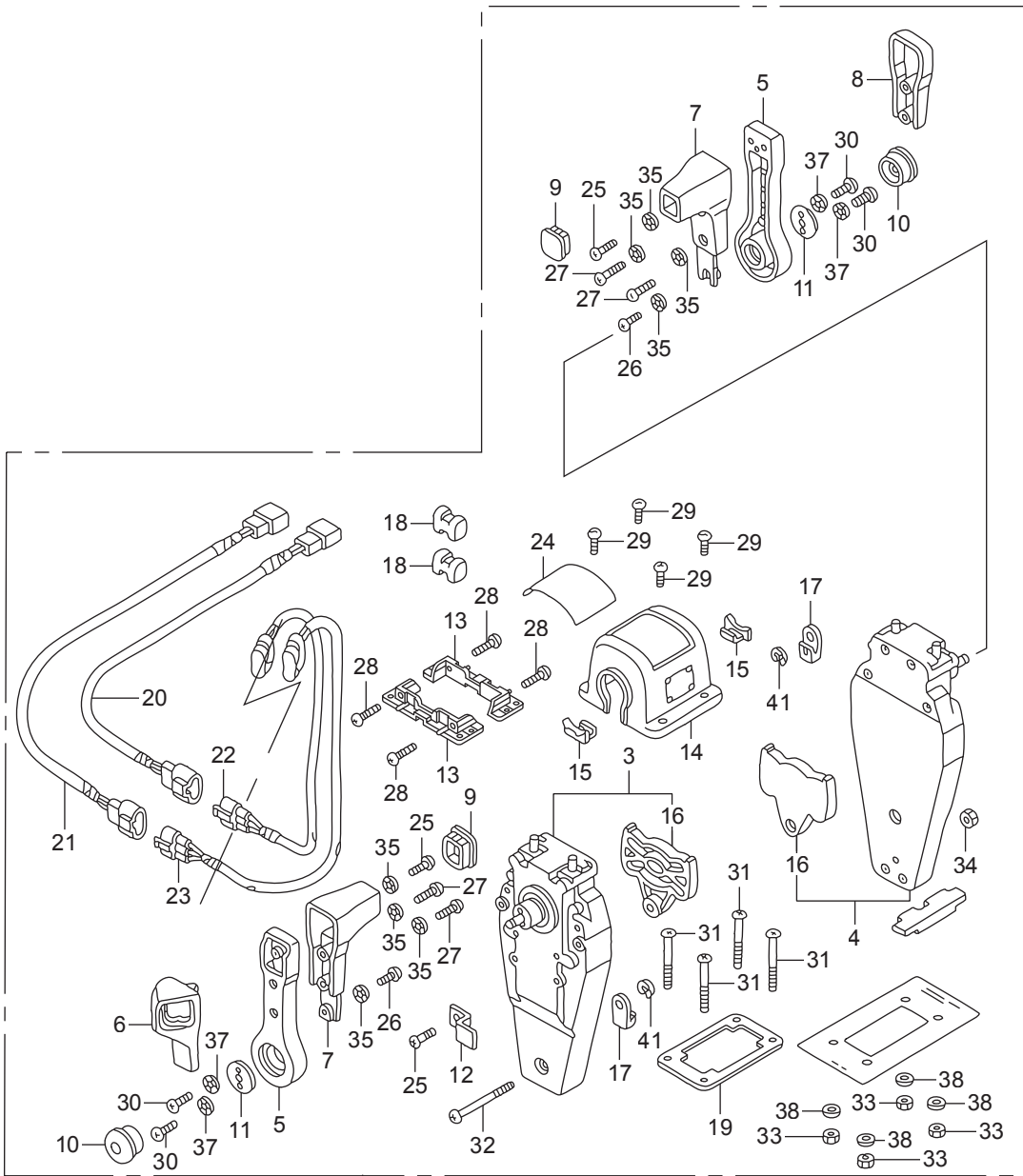

1

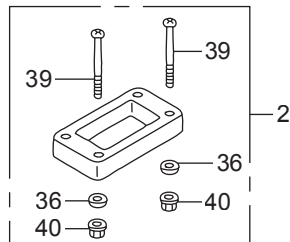

Ref.No.	Part No.	Description	Q' ty	Remarks	
			BFT250A		
FOP-1-2	1	HZZ3-06240-R60	BOX KIT, REMOTE CONTROL	1	(TOP MOUNT DUAL)(R.)
FOP-1-2	2	HZW5-06241-U10	SPACER KIT, REMOTE CONTROL BOX	1	(TOP MOUNT DUAL)
FOP-1-2	3	HZW5-24810-U01	HOUSING ASSY., L. INNER	1	(TOP MOUNT)
FOP-1-2	4	HZW5-24810-U11	HOUSING ASSY., R. INNER	1	(TOP MOUNT)
FOP-1-2	5	HZW5-24811-U01	HANDLE, REMOTE CONTROL	2	
FOP-1-2	6	HZW5-24812-U01	COVER, L. GRIP	1	
FOP-1-2	7	HZW5-24813-U01	GRIP, REMOTE CONTROL HANDLE	2	
FOP-1-2	8	HZW5-24813-U21	COVER, DUAL GRIP	1	
FOP-1-2	9	HZW5-24814-U01	CAP, GRIP	2	LA,XA,XCA
FOP-1-2	10	HZW5-24816-U01	BUTTON, THROTTLE	2	
FOP-1-2	11	HZW5-24817-U01	PLATE, HANDLE	2	
FOP-1-2	12	HZW5-24818-U01	PLATE, CABLE CLAMP	1	
FOP-1-2	13	HZW5-24819-U01	BRACKET, REMOTE CONTROL HOUSING	2	
FOP-1-2	14	HZZ3-24820-R21	HOUSING COMP., REMOTE CONTROL BOX(DUAL)	1	
FOP-1-2	15	HZW5-24825-U01	HOUSING, LEAD	2	
FOP-1-2	16	HZW5-24826-U01	PLATE, DWELL	2	
FOP-1-2	17	HZW5-24831-U01	TERMINAL, CABLE	4	
FOP-1-2	18	HZW5-24832-U01	SPACER, CABLE CLAMP	2	
FOP-1-2	19	HZW5-24834-U21	PACKING, DUAL	1	
FOP-1-2	20	HZW7-32530-U00	SUB HARNESS ASSY., POWER TRIM-TILT(A)	1	
FOP-1-2	21	HZW7-32530-U10	SUB HARNESS ASSY., POWER TRIM-TILT(B)	1	
FOP-1-2	22	HZW5-35370-U02	SWITCH ASSY., POWER TRIM-TILT (A)	1	
FOP-1-2	23	HZW5-35370-U12	SWITCH ASSY., POWER TRIM-TILT (B)	1	
FOP-1-2	24	HZZ3-87703-R01	MARK, REMOTE CONTROL(DUAL)	1	
FOP-1-2	25	HZW5-90101-U00	SCREW, PAN, 5X16	3	
FOP-1-2	26	HZW5-90102-U00	SCREW, PAN, 5X10	2	
FOP-1-2	27	HZW5-90103-U01	SCREW, PAN, 5X20	4	
FOP-1-2	28	HZW5-90104-U00	SCREW, PAN, 5X18	4	
FOP-1-2	29	HZW5-90105-U01	SCREW, PAN, 4X10	4	

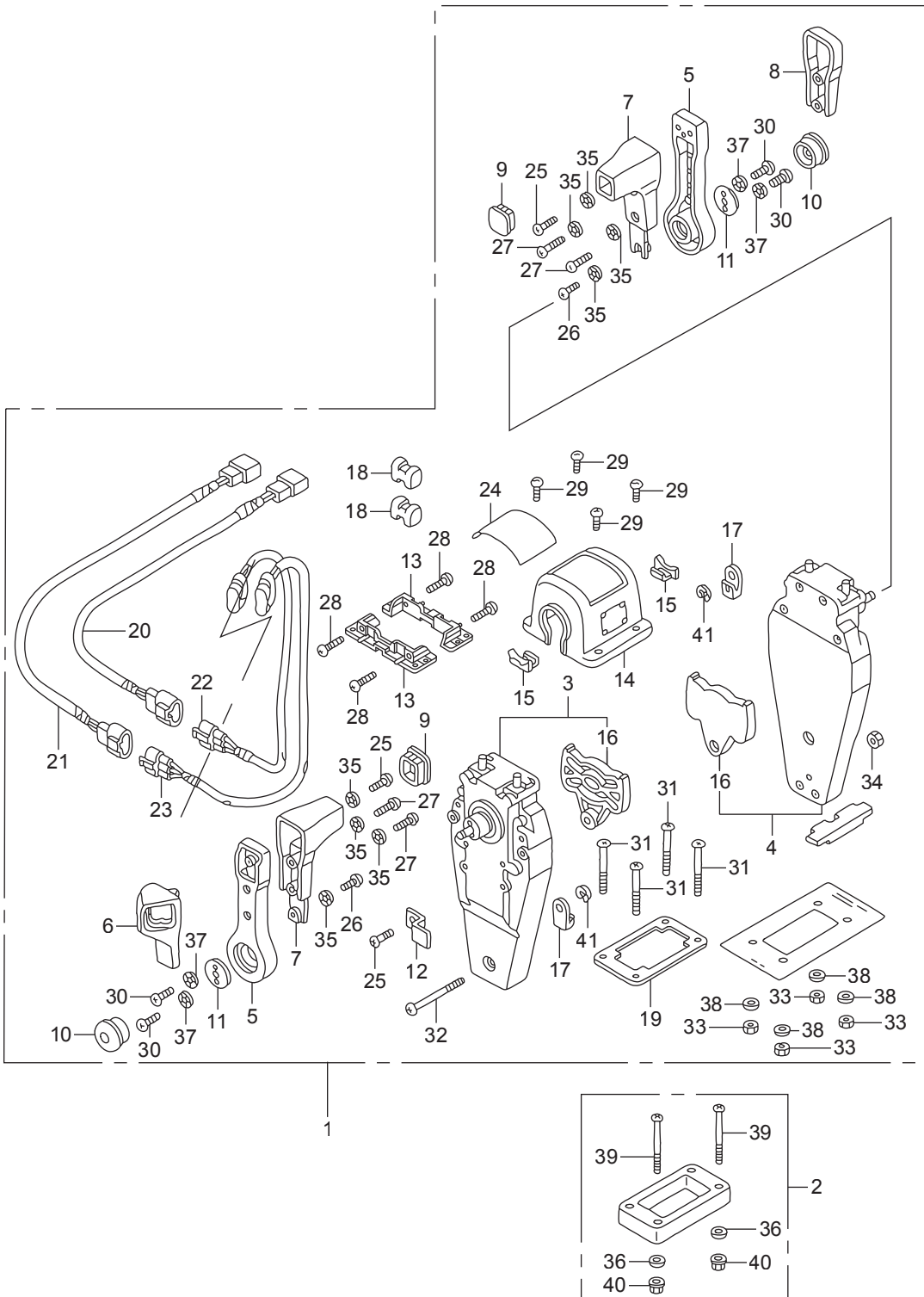

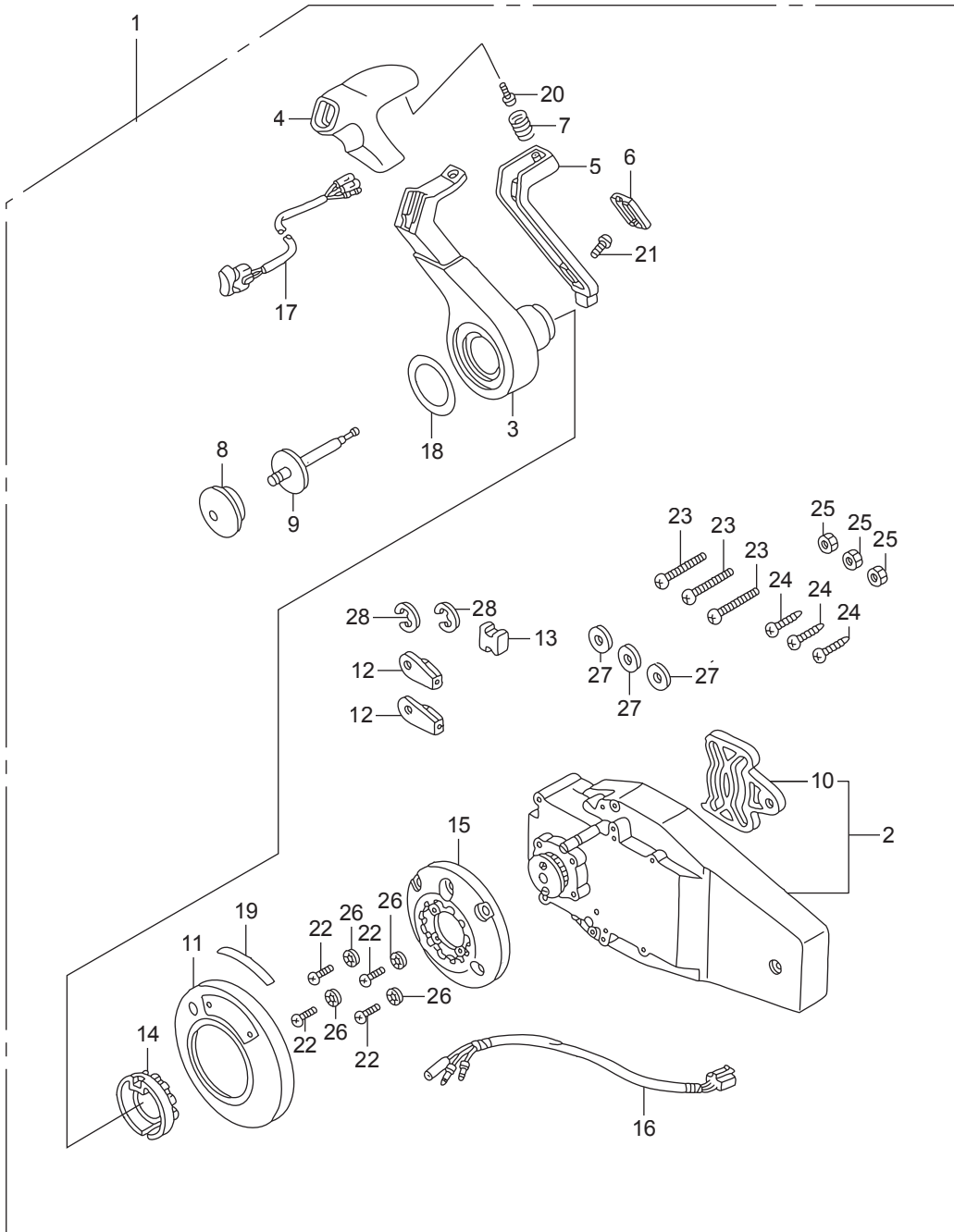

Ref.No.	Part No.	Description	Q' ty	Remarks	
			BFT250A		
FOP-1-4	1	HZZ3-06240-R40	BOX KIT, REMOTE CONTROL	1	(FLUSH MOUNT)(R.)
FOP-1-4	2	HZW7-24810-U01	HOUSING ASSY., R. INNER	1	(FLUSH MOUNT)
FOP-1-4	3	HZW7-24811-U01	HANDLE, REMOTE CONTROL	1	
FOP-1-4	4	HZW7-24812-U01	COVER, GRIP	1	
FOP-1-4	5	HZW7-24813-U01	ARM, NEUTRAL LOCK	1	
FOP-1-4	6	HZW7-24814-U01	COVER, LOCK ARM	1	
FOP-1-4	7	HZW7-24815-U01	SPRING, NEUTRAL LOCK ARM	1	
FOP-1-4	8	HZW5-24816-U01	BUTTON, THROTTLE	1	
FOP-1-4	9	HZW7-24817-U01	SHAFT, THROTTLE BUTTON	1	
FOP-1-4	10	HZW5-24826-U01	PLATE, DWELL	1	
FOP-1-4	11	HZZ3-24830-R41	COVER ASSY.	1	
FOP-1-4	12	HZW5-24831-U01	TERMINAL, CABLE	2	
FOP-1-4	13	HZW5-24832-U01	SPACER, CABLE CLAMP	1	
FOP-1-4	14	HZW7-24832-U01	HOLDER, NEUTRAL LOCK	1	
FOP-1-4	15	HZW7-24833-U01	BASE	1	
FOP-1-4	16	HZW7-32530-U20	SUB HARNESS ASSY., POWER TRIM-TILT(C)	1	
FOP-1-4	17	HZW7-35370-U02	SWITCH ASSY., POWER TRIM-TILT (C)	1	
FOP-1-4	18	HZZ3-87701-R40	MARK, HANDLE FLUSH MOUNT	1	
FOP-1-4	19	HZW7-87703-U00	MARK, FLUSH MOUNT	1	
FOP-1-4	20	HZW5-90101-U00	SCREW, PAN, 5X16	1	
FOP-1-4	21	HZW7-90101-U01	SCREW, TRUSS, 4X12	1	
FOP-1-4	22	HZW7-90102-U01	SCREW, PAN, 5X30	4	
FOP-1-4	23	HZW7-90103-U01	SCREW, PAN, 6X35	3	
FOP-1-4	24	HZW7-90104-U01	SCREW, TAPPING, 6X30	3	
FOP-1-4	25	HZW7-90301-U01	NUT, HEX., 6MM	3	
FOP-1-4	26	HZW5-90501-U00	WASHER, LOCK, 5MM	4	
FOP-1-4	27	HZW7-90502-U00	WASHER, PLAIN, 6MM	3	
FOP-1-4	28	HCO-94540-06029	E-RING, 6MM	2	

REMOTE CONTROL
(HI-LEX) (HANDLE CAP = GRAY)

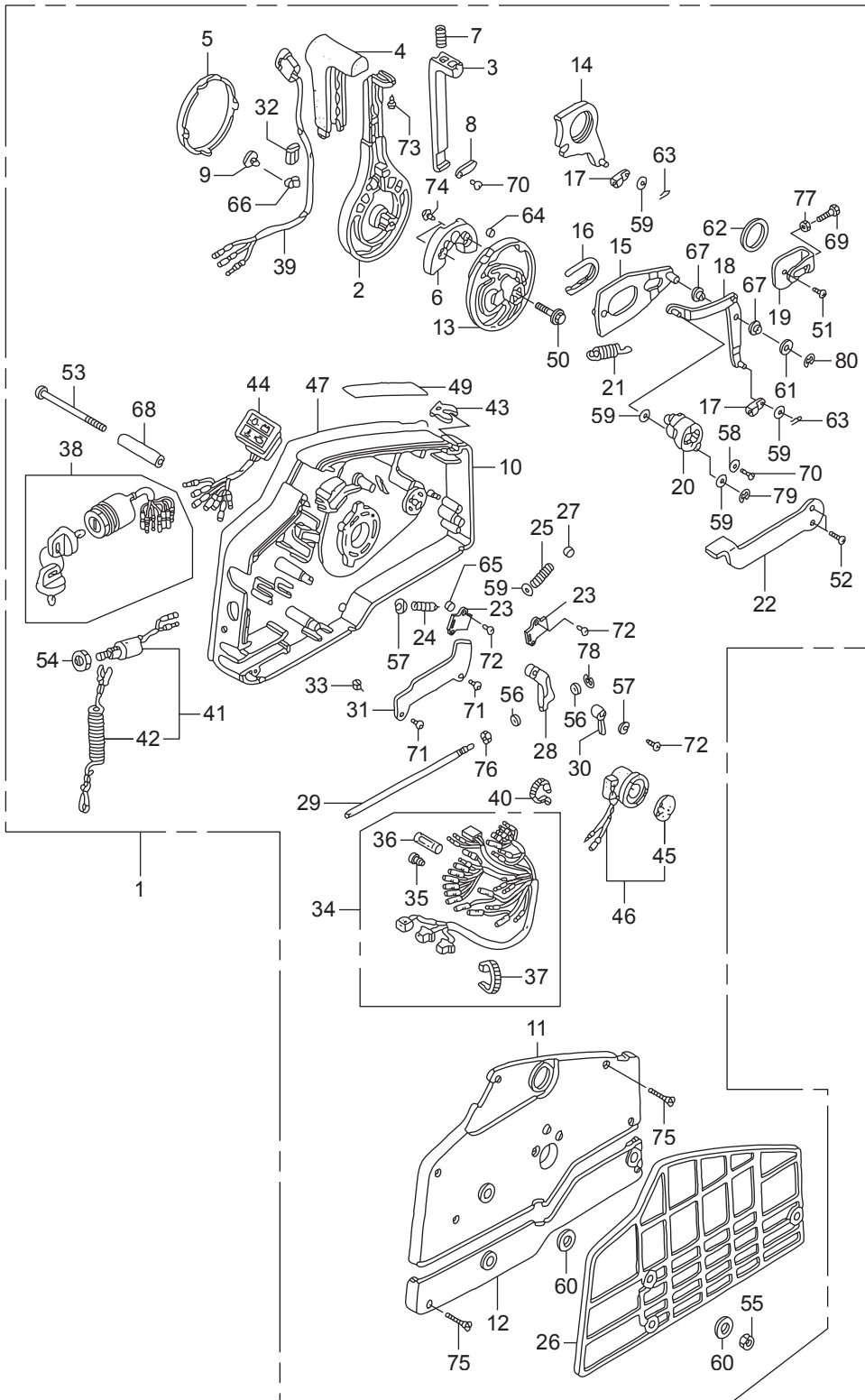

Ref.No.	Part No.	Description	Q' ty	Remarks	
			BFT250A		
FOP-1-6	1	HZZ3-24800-R00	BOX ASSY., REMOTE CONTROL(EU)	1	
FOP-1-6	2	HZV5-24811-010	HANDLE, REMOTE CONTROL	1	
FOP-1-6	3	HZV5-24812-000	LEVER, HANDLE LOCK	1	
FOP-1-6	4	HZV5-24813-000	GRIP, REMOTE CONTROL HANDLE	1	
FOP-1-6	5	HZV5-24814-010	CAP, HANDLE	1	
FOP-1-6	6	HZV5-24815-010	BLOCK, NEUTRAL LOCK	1	
FOP-1-6	7	HZV5-24816-000	SPRING, REMOTE CONTROL HANDLE	1	
FOP-1-6	8	HZV5-24817-000	PLATE, LEVER SETTING	1	
FOP-1-6	9	HZV5-24818-003	CLAMP, HARNESS	1	
FOP-1-6	10	HZV5-24820-010	HOUSING COMP., REMOTE CONTROL BOX(A)	1	
FOP-1-6	11	HZV5-24830-010	HOUSING COMP., REMOTE CONTROL BOX(B)	1	
FOP-1-6	12	HZV5-24836-000	HOUSING, REMOTE CONTROL BOX(C)	1	
FOP-1-6	13	HZV5-24841-000	WHEEL, CONTROL	1	
FOP-1-6	14	HZV5-24845-000	ARM COMP., SHIFT LINK	1	
FOP-1-6	15	HZV5-24850-000	PLATE COMP., SLIDING	1	
FOP-1-6	16	HZV5-24854-000	COLLAR, SLIDING PLATE	1	
FOP-1-6	17	HZV5-24855-000	PIVOT, SHIFT	2	
FOP-1-6	18	HZV5-24860-000	ARM COMP., LINK JOINT	1	
FOP-1-6	19	HZV5-24865-000	BRACKET, LINK JOINT	1	
FOP-1-6	20	HZV5-24875-000	WHEEL, ACCELERATOR	1	
FOP-1-6	21	HZV5-24876-000	SPRING, ACCELERATOR WHEEL	1	
FOP-1-6	22	HZV5-24878-000	LEVER, IDLE	1	
FOP-1-6	23	HZV5-24881-000	PLATE, SPRING SETTING	2	
FOP-1-6	24	HZV5-24883-000	SPRING, SHIFT CLICK	1	
FOP-1-6	25	HZV5-24884-000	SPRING, CHOKE RETURN	1	
FOP-1-6	26	HZV5-24885-000	SPACER, REMOTE CONTROL BOX	1	
FOP-1-6	27	HZV5-24887-000	SPACER, CLICK SPRING	1	
FOP-1-6	28	HZV5-24891-000	BLOCK, THROTTLE FRICTION	1	
FOP-1-6	29	HZV5-24892-000	BOLT, FRICTION	1	

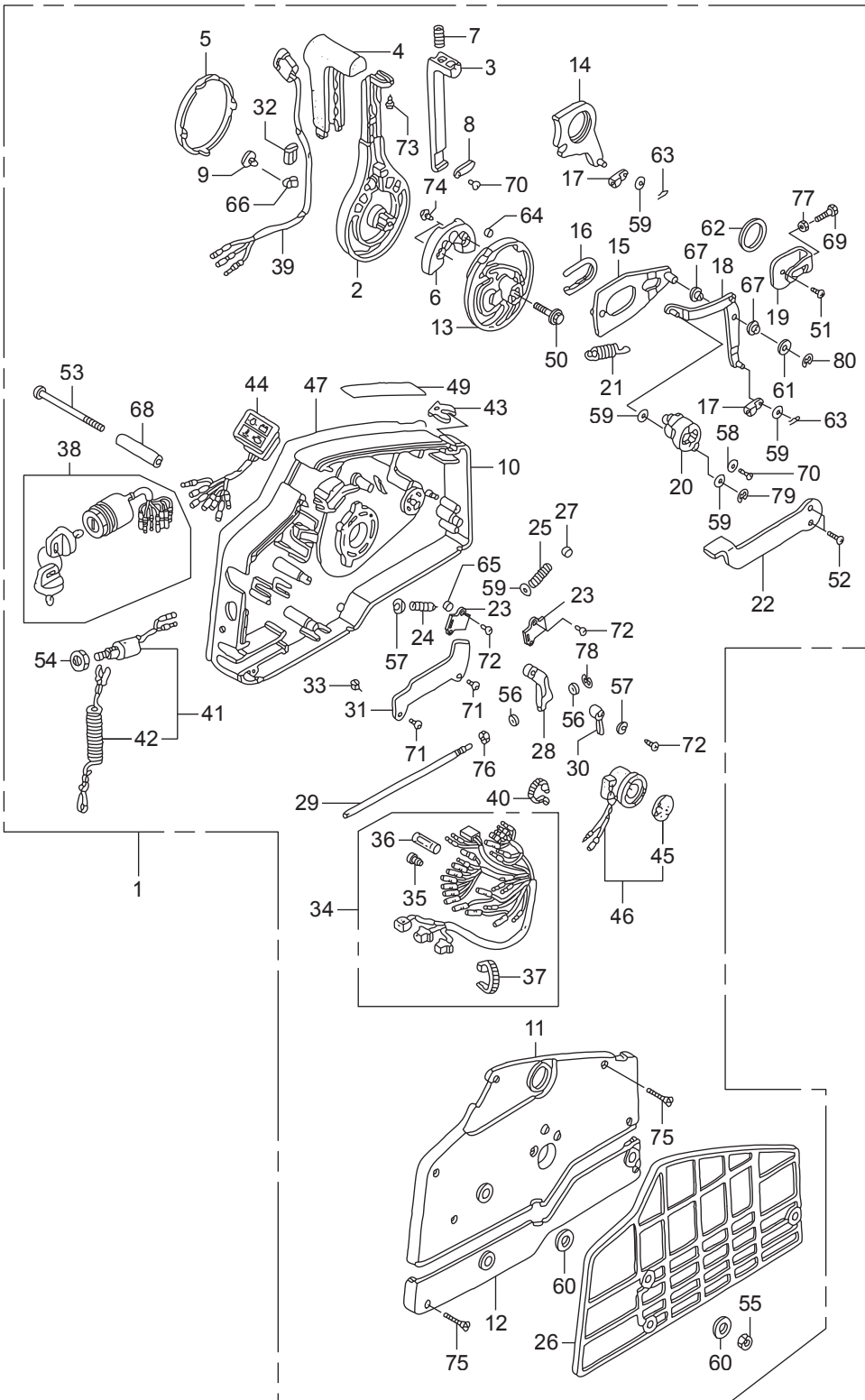

Ref.No.	Part No.	Description	Q' ty	Remarks	
			BFT250A		
FOP-1-6	30	HZV5-24894-000	SPACER, NEUTRAL SWITCH	1	
FOP-1-6	31	HZV5-24895-000	CLAMP, POWER TILT CORD	1	
FOP-1-6	32	HZV5-24897-000	PIPE, HARNESS GUIDE	1	
FOP-1-6	33	HZV5-24898-000	SPACER, CABLE CLAMP	1	
FOP-1-6	34	HZZ5-32530-000	CABLE ASSY., REMOTE CONTROL(B)	1	
FOP-1-6	35	HZV5-32823-003	PLUG, INNER CONNECTOR	7	
FOP-1-6	36	HZV5-32824-003	PLUG, OUTER CONNECTOR	1	
FOP-1-6	37	H952-32901-770	TIE, CABLE(NATURAL)(2.4X92)	1	
FOP-1-6	38	HZZ3-35100-R11	SWITCH ASSY., COMBINATION	1	
FOP-1-6	39	HZV5-35370-823	SWITCH ASSY., POWER TRIM-TILT	1	
FOP-1-6	40	HMG9-35701-950	BAND(BLACK 3.5X140)	1	
FOP-1-6	41	HZV5-36180-033	SWITCH ASSY., EMERGENCY STOP	1	
FOP-1-6	42	HZV4-36182-651	CORD COMP., EMERGENCY	1	
FOP-1-6	43	HZV4-36187-652	CLIP, EMERGENCY LOCK	1	
FOP-1-6	44	HZZ5-37210-013	LAMP ASSY., INDICATION	1	
FOP-1-6	45	H341-38403-672	PLATE, WINKER BUZZER	1	
FOP-1-6	46	HZV5-38410-003	BUZZER COMP., WARNING	1	
FOP-1-6	47	HZZ3-87701-R00	PLATE, REMOTE CONTROL	1	
FOP-1-6	49	HZW9-87702-800	MARK, FAST IDLE	1	
FOP-1-6	50	HZW9-90008-000	BOLT, FLANGE, 8X35	1	
FOP-1-6	51	HMM4-90105-000	SCREW, PAN, 6X10	1	
FOP-1-6	52	HZW4-90108-000	SCREW, FLAT, 5X12	2	
FOP-1-6	53	HZV5-90125-000	SCREW, 6X95	3	
FOP-1-6	54	H921-90302-000	NUT, HEX., 16MM	1	
FOP-1-6	55	HZV4-90304-000	NUT, HEX., 6MM	3	
FOP-1-6	56	HZW4-90401-000	WASHER, PLAIN, 4MM	2	
FOP-1-6	57	HZW4-90402-000	WASHER, PLAIN, 5MM	2	
FOP-1-6	58	HZV4-90502-000	WASHER, PLAIN, 5MM	1	
FOP-1-6	59	H921-90504-010	WASHER, PLAIN, 6MM	5	

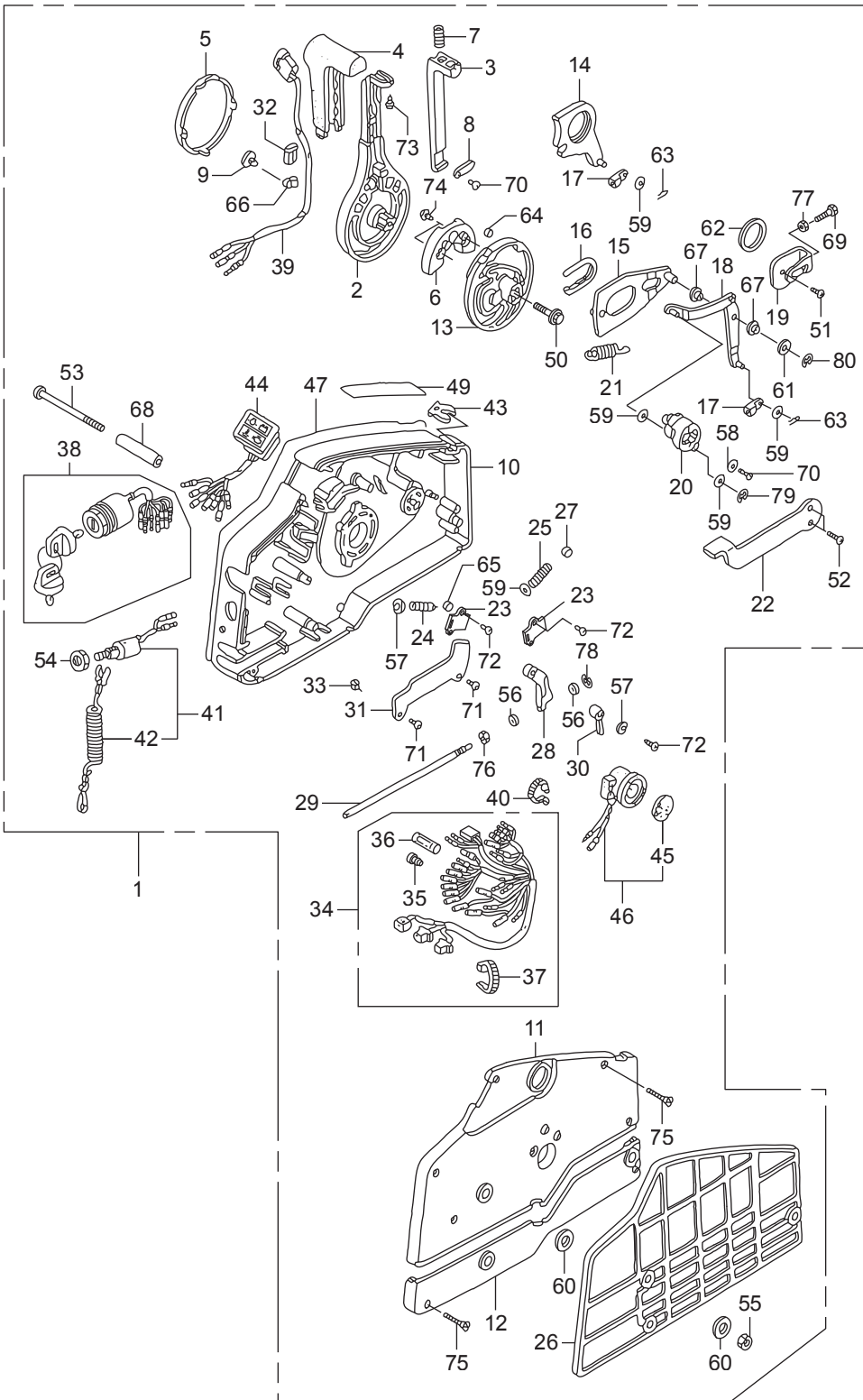

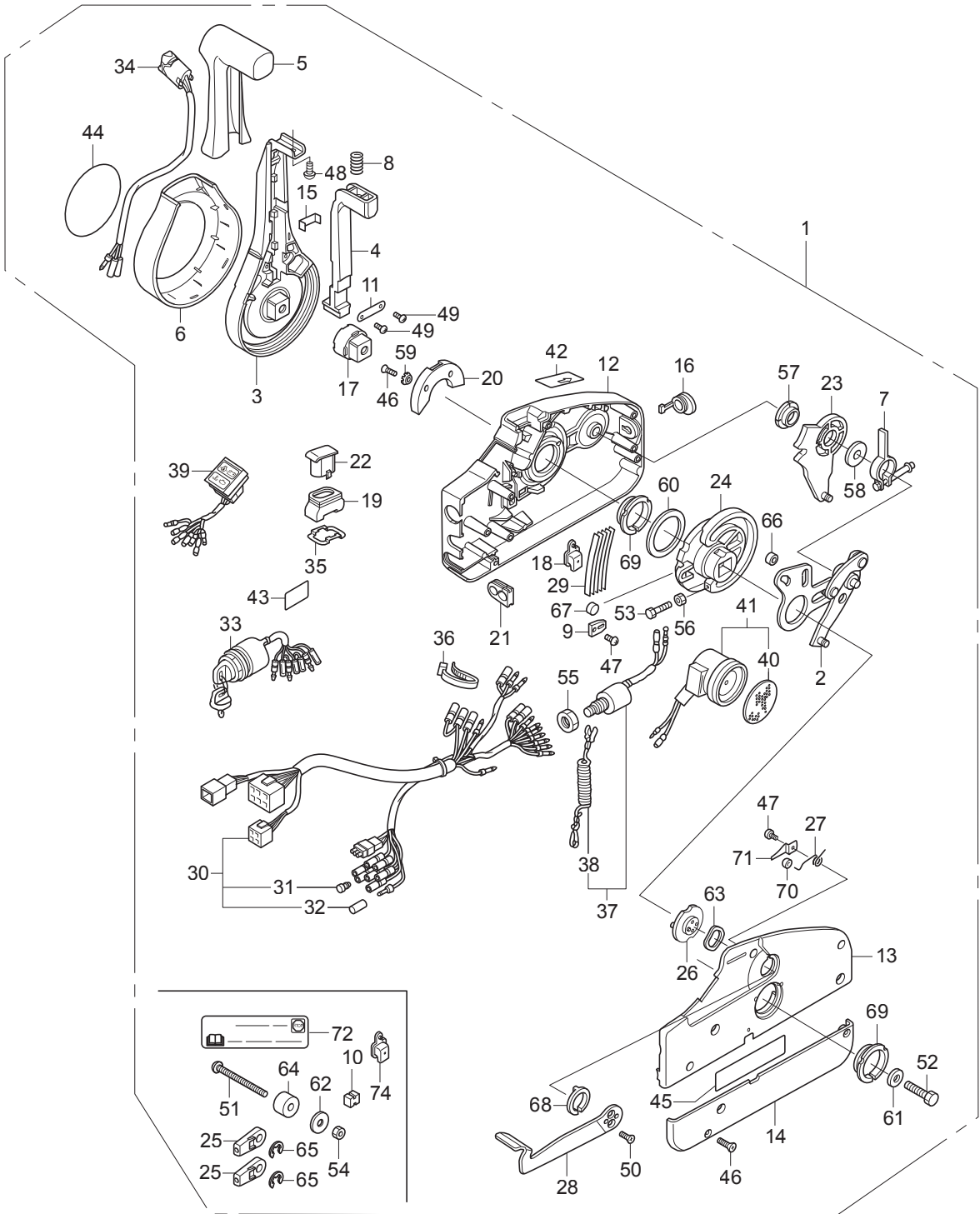

Ref.No.	Part No.	Description	Q' ty	Remarks
			BFT250A	
FOP-1-7	1	HZZ3-24800-P12	BOX ASSY., REMOTE CONTROL (NHK MEC)	1
FOP-1-7	2	HZZ5-24810-D01	PLATE ASSY.	1
FOP-1-7	3	HZZ5-24811-D01	LEVER, HAND	1
FOP-1-7	4	HZZ5-24812-D01	ARM, NEUTRAL LOCK	1
FOP-1-7	5	HZZ5-24813-D01	GRIP	1
FOP-1-7	6	HZZ5-24814-D01	COVER, LEVER	1
FOP-1-7	7	HZZ5-24815-D01	ARM ASSY., BRAKE	1
FOP-1-7	8	HZZ5-24816-D01	SPRING(2)	1
FOP-1-7	9	HZZ5-24817-D01	CLIP, DETENT	1
FOP-1-7	10	HZZ5-24818-D01	SPACER(1)(LOOSE PARTS)	1
FOP-1-7	11	HZZ5-24819-D01	BRACKET	1
FOP-1-7	12	HZZ5-24821-D01	HOUSING, FR.	1
FOP-1-7	13	HZZ5-24822-D01	HOUSING, RR.	1
FOP-1-7	14	HZZ5-24823-D01	PANEL, BACK	1
FOP-1-7	15	HZZ5-24824-D01	BRACKET, WIRE CLAMP	1
FOP-1-7	16	HZZ5-24826-D01	CAP, RUBBER	1
FOP-1-7	17	HZZ5-24827-D01	ADJUSTER	1
FOP-1-7	18	HZZ5-24828-D01	COVER, POWER TRIM-TILT WIRE	1
FOP-1-7	19	HZZ5-24829-D01	SEAL, RUBBER	1
FOP-1-7	20	HZZ5-24831-D01	HOLDER, NEUTRAL LOCK	1
FOP-1-7	21	HZZ5-24832-D01	GROMMET, WIRE(14)	1
FOP-1-7	22	HZZ5-24833-D01	CAP, TROLLING CONTROL SWITCH	1
FOP-1-7	23	HZZ5-24845-D01	GEAR ASSY., SHIFT	1
FOP-1-7	24	HZZ5-24850-D01	GEAR, DRIVE	1
FOP-1-7	25	HZZ5-24855-D01	TERMINAL, CABLE(LOOSE PARTS)	2
FOP-1-7	26	HZZ5-24875-D01	DRUM ASSY., FREE THROTTLE	1
FOP-1-7	27	HZZ5-24876-D01	SPRING(1)	1
FOP-1-7	28	HZZ5-24878-D01	LEVER, FREE THROTTLE	1
FOP-1-7	29	HZZ5-24883-D01	SPRING, DETENT	5

Ref.No.	Part No.	Description	Q' ty	Remarks	
			BFT250A		
FOP-1-7	30	HZZ5-32530-D01	CABLE ASSY., REMOTE CONTROL(B)	1	
FOP-1-7	31	HZV5-32823-003	PLUG, INNER CONNECTOR	7	
FOP-1-7	32	HZV5-32824-003	PLUG, OUTER CONNECTOR	1	
FOP-1-7	33	HZZ3-35100-R11	SWITCH ASSY., COMBINATION	1	
FOP-1-7	34	HZZ5-35370-D02	SWITCH ASSY., POWER TRIM-TILT	1	
FOP-1-7	35	HZZ3-35645-A41	PLATE, SWITCH	1	
FOP-1-7	36	HZZ5-35701-D01	BAND, WIRE	1	
FOP-1-7	37	HZV5-36180-033	SWITCH ASSY., EMERGENCY STOP	1	
FOP-1-7	38	HZV4-36182-651	CORD COMP., EMERGENCY	1	
FOP-1-7	39	HZZ5-37210-D01	LAMP ASSY., INDICATION	1	
FOP-1-7	40	H341-38403-672	PLATE, WINKER BUZZER	1	
FOP-1-7	41	HZV5-38410-003	BUZZER COMP., WARNING	1	
FOP-1-7	42	HZZ5-87701-D00	MARK, FAST IDLE	1	
FOP-1-7	43	HZZ5-87702-A00	MARK, EMERGENCY STOP(US)	1	
FOP-1-7	44	HZZ5-87703-P00	MARK, EMBLEM	1	
FOP-1-7	45	HZZ5-87704-D01	LABEL, SIGP	1	
FOP-1-7	46	HZZ5-90101-D01	SCREW, 5X18	7	
FOP-1-7	47	HZZ5-90102-D01	SCREW, 4X6	2	
FOP-1-7	48	HZZ5-90103-D01	SCREW, 5X10	1	
FOP-1-7	49	HZZ5-90104-D01	SCREW, 4X10	2	
FOP-1-7	50	HZZ5-90106-D01	SCREW, 5X12	2	
FOP-1-7	51	HZZ5-90107-D01	SCREW, 6X90(LOOSE PARTS)	3	
FOP-1-7	52	HZZ5-90108-D01	BOLT, 8X50	1	
FOP-1-7	53	HZZ5-90109-D01	BOLT, 5X25	1	
FOP-1-7	54	HZZ5-90301-D01	NUT, 6MM(LOOSE PARTS)	3	
FOP-1-7	55	H921-90302-000	NUT, HEX., 16MM	1	
FOP-1-7	56	HZZ5-90302-D01	NUT, 5MM	1	
FOP-1-7	57	HZZ5-90501-D01	BEARING(1)	1	
FOP-1-7	58	HZZ5-90502-D01	WASHER(3)	1	

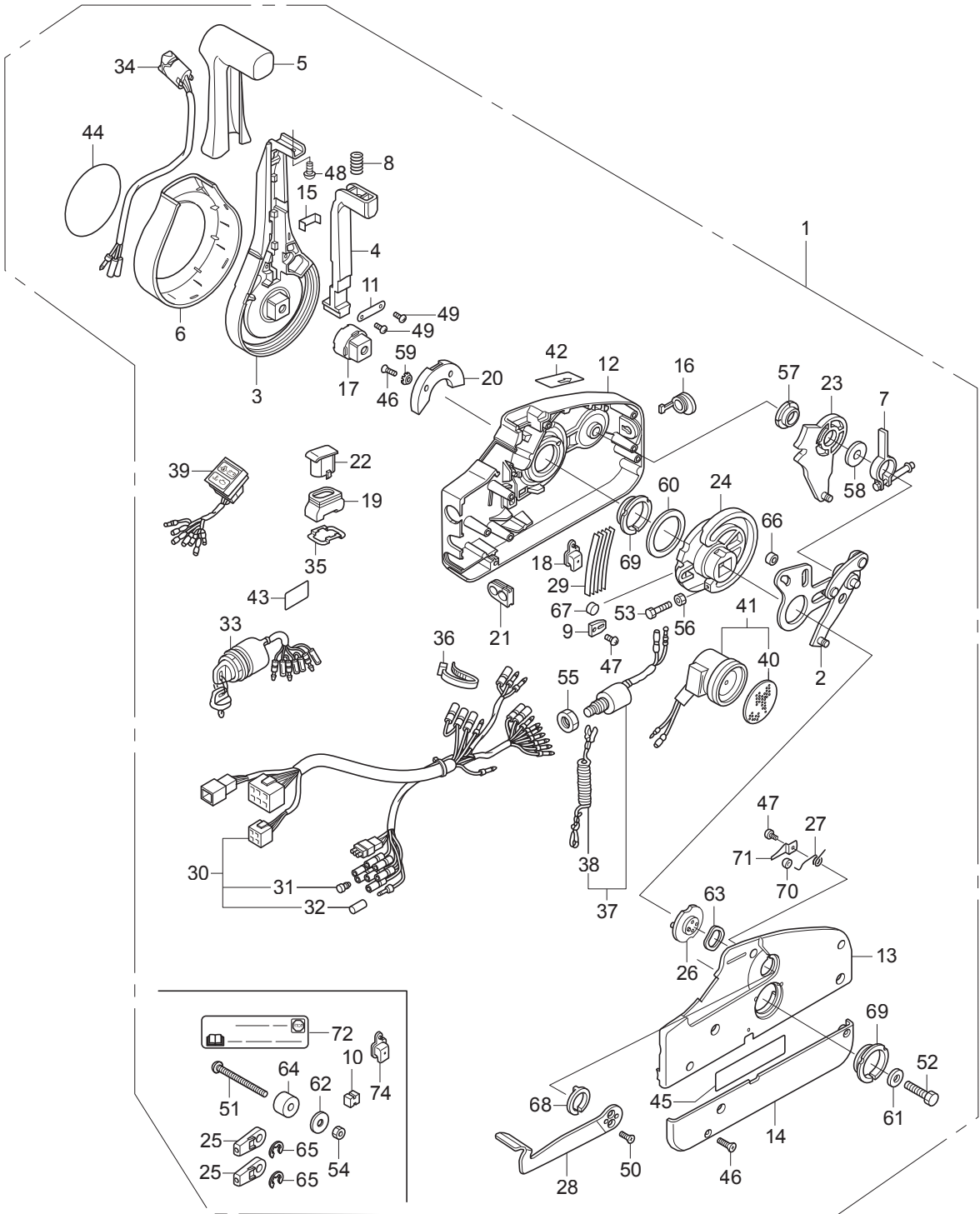

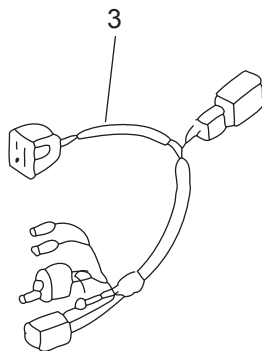
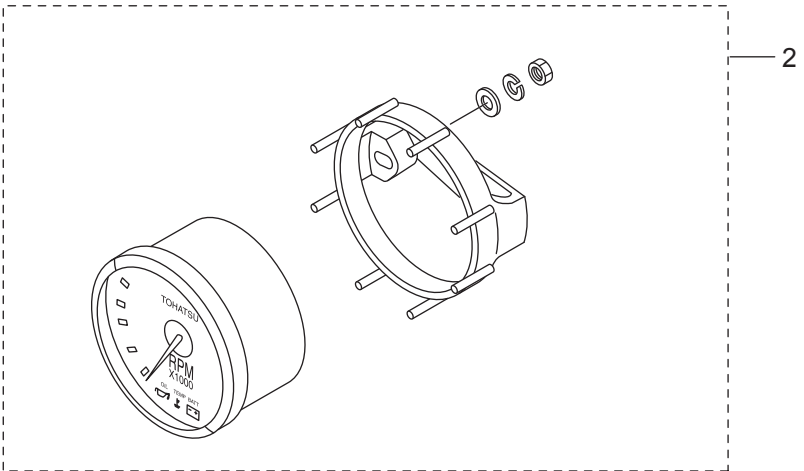
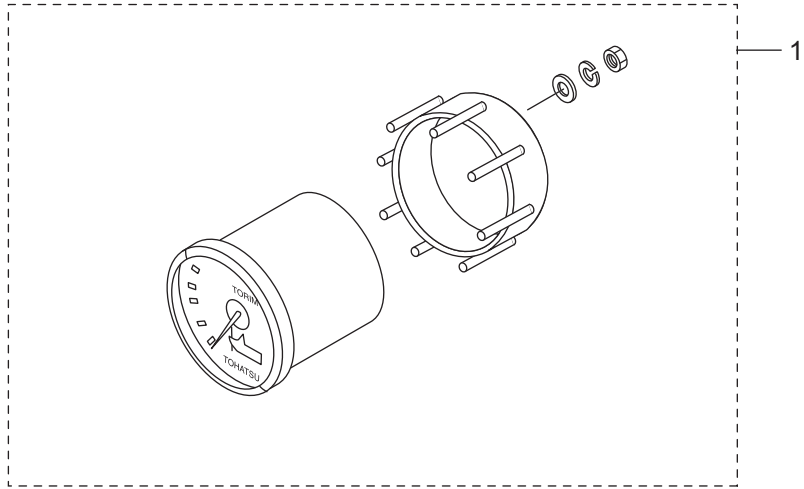

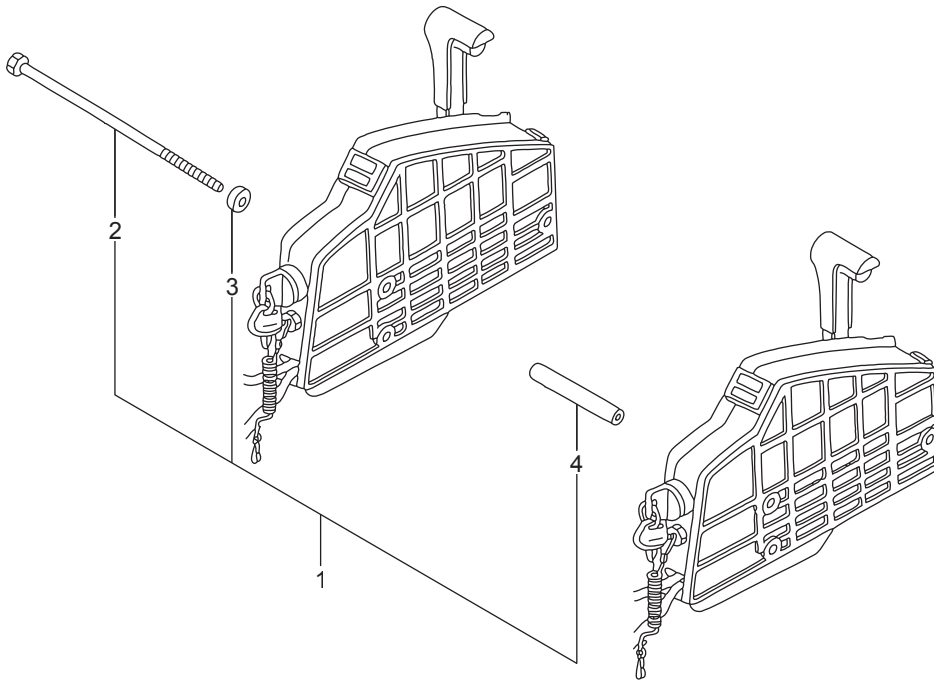

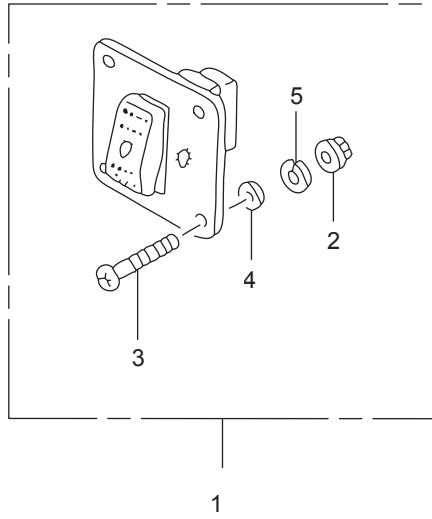

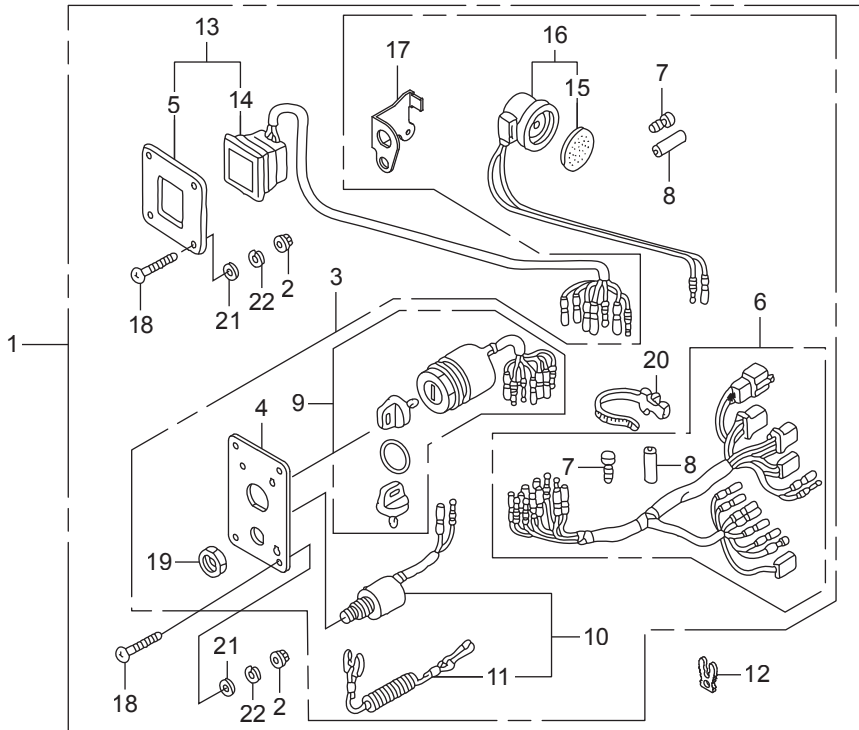

Ref.No.	Part No.	Description	Q' ty	Remarks	
			BFT250A		
FOP-7	1	HZZ3-06323-R20	PANEL KIT, SWITCH(B)(4-LED)	1	
FOP-7	2	HMT8-18334-770	NUT, FLANGE, 5MM	8	
FOP-7	3	HZZ3-32341-R31	PANEL ASSY., SWITCH	1	
FOP-7	4	HZZ3-32346-R21	PANEL, CONTROL	1	
FOP-7	5	HZZ3-32347-R01	PANEL, CONTROL	1	
FOP-7	6	HZZ5-32545-000	HARNESS ASSY., SWITCH PANEL	1	
FOP-7	7	HZV5-32823-003	PLUG, INNER CONNECTOR	8	
FOP-7	8	HZV5-32824-003	PLUG, OUTER CONNECTOR	3	
FOP-7	9	HZZ3-35100-R11	SWITCH ASSY., COMBINATION	1	
FOP-7	10	HZV5-36180-033	SWITCH ASSY., EMERGENCY STOP	1	
FOP-7	11	HZV4-36182-651	CORD COMP., EMERGENCY	1	
FOP-7	12	HZV4-36187-652	CLIP, EMERGENCY LOCK	1	
FOP-7	13	HZZ3-37205-R01	PANEL ASSY., INDICATOR(4-LED)	1	
FOP-7	14	HZZ5-37210-762	LAMP ASSY., INDICATION(4-LED)	1	
FOP-7	15	H341-38403-672	PLATE, WINKER BUZZER	1	
FOP-7	16	HZV5-38410-003	BUZZER COMP., WARNING	1	
FOP-7	17	HZZ5-38414-003	BRACKET, BUZZER	1	
FOP-7	18	HZW5-90109-000	SCREW, PAN, 5X40	8	
FOP-7	19	H921-90302-000	NUT, HEX., 16MM	1	
FOP-7	20	HSC2-90649-003	BAND, WIRE HARNESS(NATURAL)	1	(150MM)
FOP-7	21	HCO-94103-05400	WASHER, PLAIN, 5MM	8	
FOP-7	22	HCO-94111-05400	WASHER, SPRING, 5MM	8	

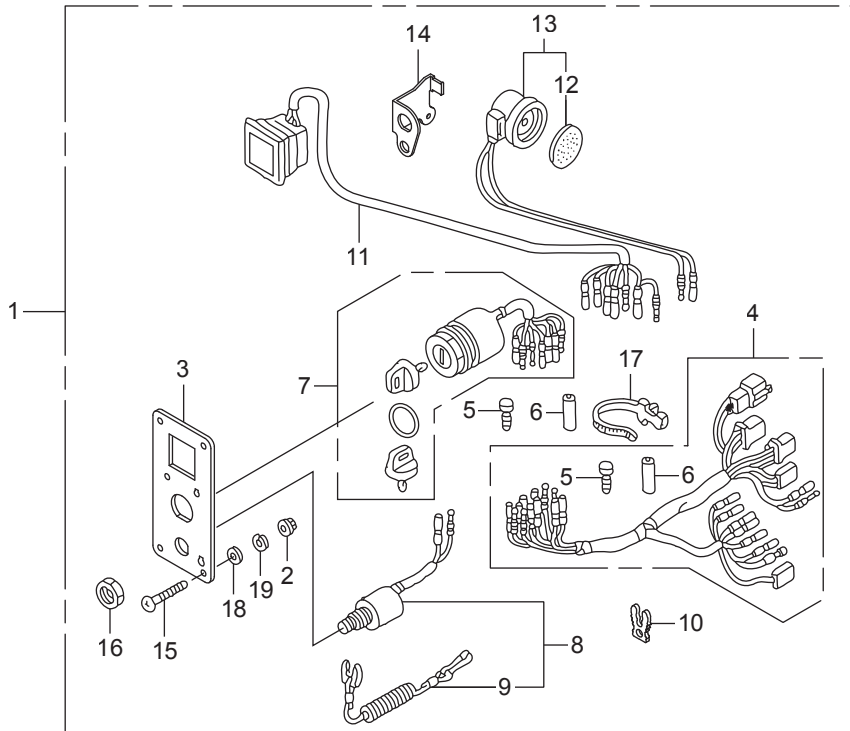

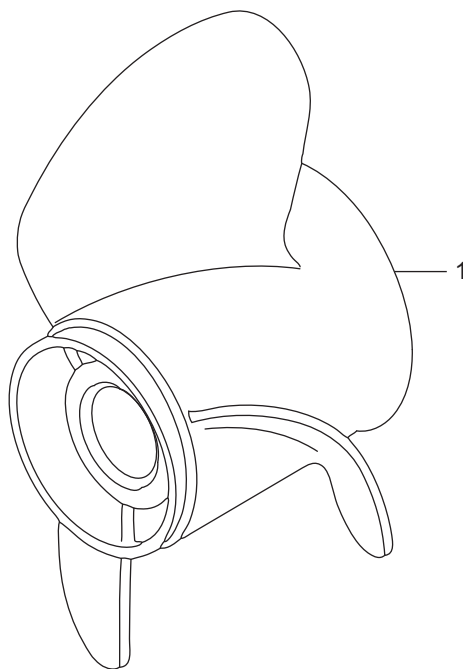

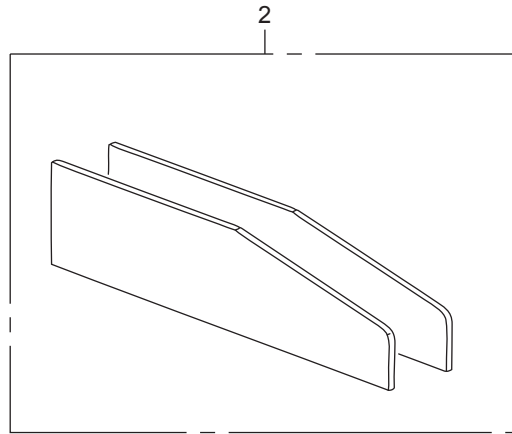
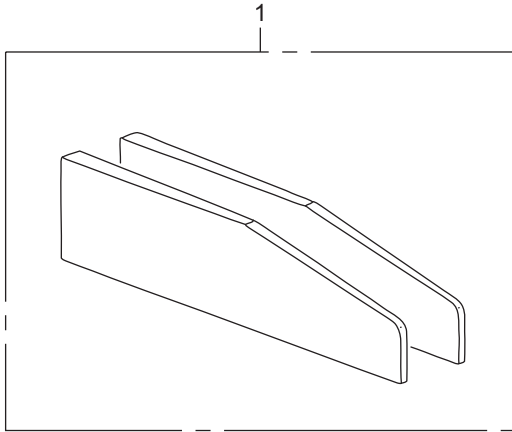

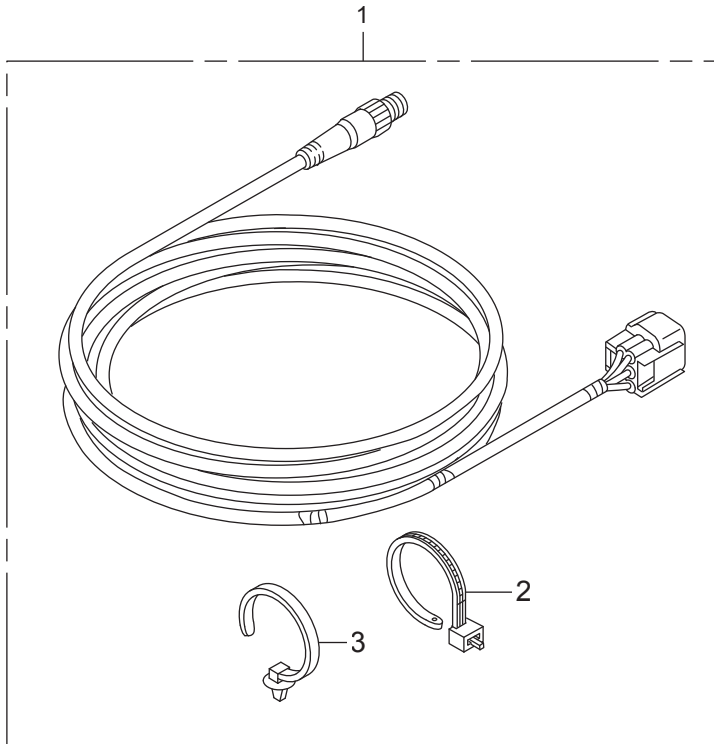

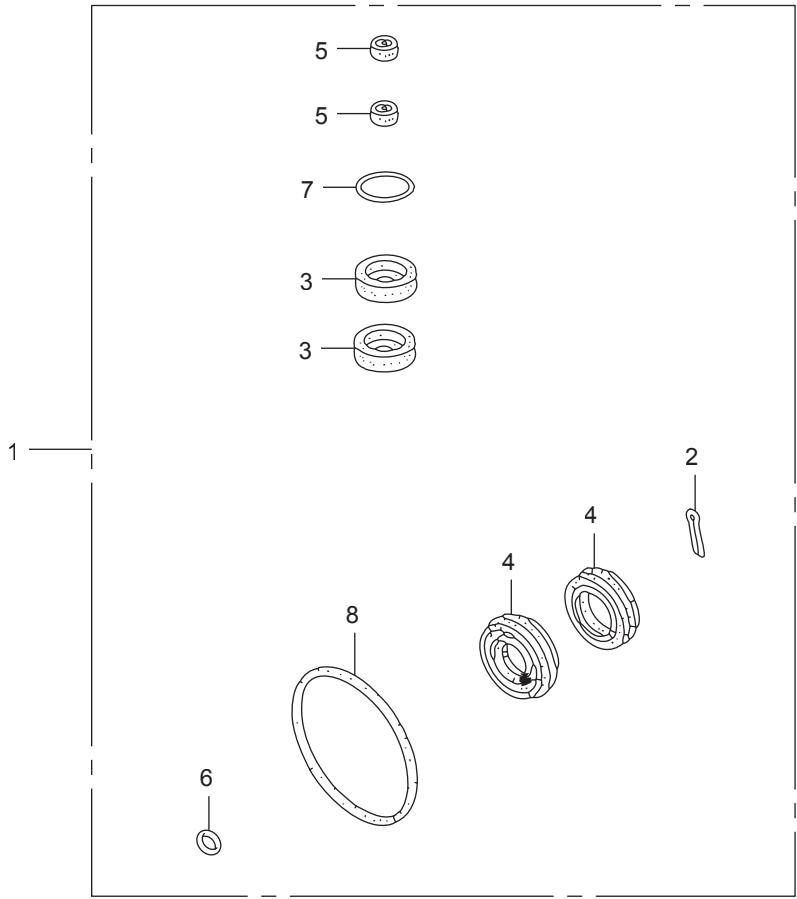

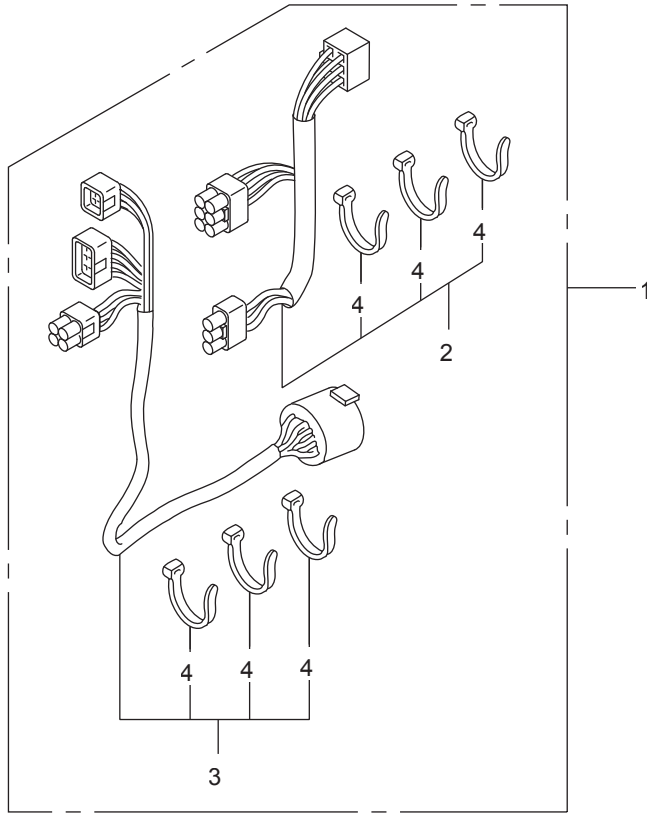

INDEX

<A>			
ADJUSTER.....	FOP-1-7-17	BLOCK, THROTTLE FRICTION	FOP-1-6-28
ARM ASSY., BRAKE.....	FOP-1-7-7	BODY	E-18-3
ARM ASSY., INTAKE ROCKER.....	E-9-10-4	BODY, OIL JET	E-3-13
ARM COMP. A, EX. ROCKER	E-9-10-5	BOLT A, THROUGH.....	E-21-14
ARM COMP. B, EX. ROCKER	E-9-10-6	BOLT COMP., OIL JET	E-3-14
ARM COMP., LINK JOINT	FOP-1-6-18	BOLT KIT, SIDE REMOTE CONTROL.....	FOP-5-1
ARM COMP., SHIFT LINK.....	FOP-1-6-14	BOLT, 1/4-28UNF	F-10-36
ARM, FUEL PUMP ROCKER	E-9-10-3	BOLT, 12MM.....	E-5-13
ARM, NEUTRAL LOCK	FOP-1-4-5	BOLT, 3/8-24UNF	F-10-43
ARM, NEUTRAL LOCK	FOP-1-7-4	BOLT, 5X25.....	FOP-1-7-53
ARM, SHIFT.....	F-2-9	BOLT, 8X50.....	FOP-1-7-52
ARM, THROTTLE	F-2-3	BOLT, CONNECTING ROD	E-7-6
ARMATURE COMP.....	F-11-7	BOLT, COVER LOCK	F-8-12
		BOLT, DRAIN PLUG	E-6-11
BAG, TOOL, 200MM.....	F-13-13	BOLT, DRAIN PLUG	F-3-14
BALL, STEEL	E-21-6	BOLT, FLANGE, 10X110	E-21-20
BALL, STEEL, #12(3/8).....	F-5-33	BOLT, FLANGE, 10X120(SATO).....	E-6-20-2
BALL, STEEL, #12(3/8).....	F-5-1-36	BOLT, FLANGE, 10X40	E-13-26
BALL, STEEL, #7(7/32).....	F-5-32	BOLT, FLANGE, 10X43.....	E-13-27
BALL, STEEL, #7(7/32).....	F-5-1-35	BOLT, FLANGE, 10X55.....	E-3-10-10
BAND	E-18-42	BOLT, FLANGE, 10X70	E-6-20-11
BAND(BLACK 3.5X140).....	F-11-3	BOLT, FLANGE, 10X90	E-19-21
BAND(BLACK 3.5X140).....	FOP-1-6-40	BOLT, FLANGE, 10X90	E-21-19
BAND, AIR FLOW	E-15-8	BOLT, FLANGE, 12X120	E-6-20-12
BAND, TUBE CLIP, 12.5MM	F-8-20-4	BOLT, FLANGE, 12X95.....	E-3-28
BAND, UNDER CASE GROMMET	F-8-10-4	BOLT, FLANGE, 5X10	E-14-10-17
BAND, WIRE	F-10-6	BOLT, FLANGE, 5X14	E-13-10-9
BAND, WIRE	F-10-76	BOLT, FLANGE, 6X10	E-14-22
BAND, WIRE	FOP-1-7-36	BOLT, FLANGE, 6X10	E-18-1-25
BAND, WIRE HARNESS	F-7-10-20	BOLT, FLANGE, 6X10	E-20-10-8
BAND, WIRE HARNESS.....	F-7-10-20	BOLT, FLANGE, 6X10.....	F-7-10-15
BAND, WIRE HARNESS(NATURAL)	FOP-7-20	BOLT, FLANGE, 6X11	F-2-24
BAND, WIRE HARNESS(NATURAL)	FOP-7-1-17	BOLT, FLANGE, 6X12	E-18-51
BAND, WIRE, 165MM(BLACK).....	F-7-10-20	BOLT, FLANGE, 6X12	E-18-1-26
BASE	FOP-1-4-15	BOLT, FLANGE, 6X12	F-2-26
BASE COMP., TIMING BELT TENSIONER.....	E-13-10	BOLT, FLANGE, 6X12	F-7-10-14
BASE, L. INJECTOR	E-14-13	BOLT, FLANGE, 6X12	F-8-10-29
BASE, R. INJECTOR	E-14-11	BOLT, FLANGE, 6X12	F-10-37
BEARING A, CONNECTING ROD (BLACK)	E-7-8	BOLT, FLANGE, 6X14	E-3-35
BEARING A, MAIN LOWER(BLACK)	E-7-12	BOLT, FLANGE, 6X14	E-5-21
BEARING A, MAIN UPPER(BLACK)	E-7-10	BOLT, FLANGE, 6X14	E-14-21
BEARING B, CONNECTING ROD (BROWN)	E-7-8	BOLT, FLANGE, 6X14	E-18-50
BEARING B, MAIN LOWER(BROWN)	E-7-12	BOLT, FLANGE, 6X14	F-8-10-27
BEARING B, MAIN UPPER(BROWN)	E-7-10	BOLT, FLANGE, 6X14(CT200)	E-1-16
BEARING C, CONNECTING ROD (GREEN)	E-7-8	BOLT, FLANGE, 6X14(CT200)	E-13-20
BEARING C, MAIN LOWER(GREEN)	E-7-12	BOLT, FLANGE, 6X14(CT200)	F-2-22
BEARING C, MAIN UPPER(GREEN)	E-7-10	BOLT, FLANGE, 6X16	E-3-33
BEARING D, CONNECTING ROD (YELLOW)	E-7-8	BOLT, FLANGE, 6X16	E-13-23
BEARING D, MAIN LOWER(YELLOW)	E-7-12	BOLT, FLANGE, 6X16	E-18-49
BEARING D, MAIN UPPER(YELLOW)	E-7-10	BOLT, FLANGE, 6X16	E-19-23
BEARING E, CONNECTING ROD (PINK)	E-7-8	BOLT, FLANGE, 6X16	F-2-23
BEARING E, MAIN LOWER(PINK)	E-7-12	BOLT, FLANGE, 6X16	F-4-18
BEARING E, MAIN UPPER(PINK)	E-7-10	BOLT, FLANGE, 6X18	E-3-36
BEARING F, MAIN LOWER(RED)	E-7-12	BOLT, FLANGE, 6X18	E-5-22
BEARING F, MAIN UPPER(RED)	E-7-10	BOLT, FLANGE, 6X20	E-20-10-9
BEARING(1).....	FOP-1-7-57	BOLT, FLANGE, 6X20	F-7-20-7
BEARING(2).....	FOP-1-7-68	BOLT, FLANGE, 6X20	F-8-11
BEARING(3).....	FOP-1-7-69	BOLT, FLANGE, 6X20	F-8-10-30
BEARING, FR. GENERATOR.....	E-19-3	BOLT, FLANGE, 6X20	F-10-34
BEARING, NEEDLE, 20X28X13	E-6-10-34	BOLT, FLANGE, 6X20	F-10-40
BEARING, NEEDLE, 28X39X30	F-5-26	BOLT, FLANGE, 6X22	E-3-37
BEARING, NEEDLE, 28X39X30	F-5-1-29	BOLT, FLANGE, 6X22	E-3-10-8
BEARING, NEEDLE, 30.5X47X37	F-4-25	BOLT, FLANGE, 6X22	E-6-10-24
BEARING, NEEDLE, 32X42X30	F-5-27	BOLT, FLANGE, 6X22	E-13-24
BEARING, NEEDLE, 32X42X30	F-5-1-30	BOLT, FLANGE, 6X22	E-14-10-14
BEARING, NEEDLE, 50X72X4.5	F-5-1-25	BOLT, FLANGE, 6X22	E-15-21
BEARING, RADIAL BALL	F-5-25	BOLT, FLANGE, 6X23	F-10-35
BEARING, RADIAL BALL	F-5-1-28	BOLT, FLANGE, 6X25	E-14-19
BEARING, RR. GENERATOR	E-19-2	BOLT, FLANGE, 6X25	E-18-48
BEARING, TAPER ROLLER	F-4-26	BOLT, FLANGE, 6X32	E-3-10-9
BEARING, TAPER ROLLER	F-5-24	BOLT, FLANGE, 6X32	E-6-10-25
BEARING, THRUST NEEDLE	F-5-1-27	BOLT, FLANGE, 6X32	E-14-10-16
BEARING, THRUST(F)	F-5-23	BOLT, FLANGE, 6X35	E-1-17
BEARING, THRUST(F)	F-5-1-24	BOLT, FLANGE, 6X35	E-3-34
BELT, A.C. GENERATOR	E-13-17	BOLT, FLANGE, 6X35	E-4-16
BELT, TIMING(197YU26 B-333).....	E-13-6	BOLT, FLANGE, 6X35	E-14-20
BLOCK ASSY., CYLINDER	E-3-3	BOLT, FLANGE, 6X37	E-3-10-11
BLOCK, NEUTRAL LOCK	FOP-1-6-6	BOLT, FLANGE, 6X40	E-6-10-31
		BOLT, FLANGE, 6X55	E-3-10-14
		BOLT, FLANGE, 6X60	E-4-18
		BOLT, FLANGE, 6X60	E-15-22
		BOLT, FLANGE, 8X100.....	E-6-10-27
		BOLT, FLANGE, 8X18	F-7-10-16
		BOLT, FLANGE, 8X20	E-9-12
		BOLT, FLANGE, 8X22	F-8-10-31
		BOLT, FLANGE, 8X25	E-3-10-15
		BOLT, FLANGE, 8X28	E-9-13
		BOLT, FLANGE, 8X30	E-5-23
		BOLT, FLANGE, 8X30	E-6-10-29
		BOLT, FLANGE, 8X30	E-9-10-18
		BOLT, FLANGE, 8X32	E-1-18
		BOLT, FLANGE, 8X35	E-18-52
		BOLT, FLANGE, 8X35	FOP-1-6-50
		BOLT, FLANGE, 8X40	E-4-19
		BOLT, FLANGE, 8X40	E-9-10-19
		BOLT, FLANGE, 8X45	E-1-19
		BOLT, FLANGE, 8X50	E-3-40
		BOLT, FLANGE, 8X50	E-14-10-18
		BOLT, FLANGE, 8X60	E-4-17
		BOLT, FLANGE, 8X65	E-15-23
		BOLT, FLANGE, 8X75	E-3-38
		BOLT, FLANRNG, 6X12	F-7-3
		BOLT, FRICTION.....	FOP-1-6-29
		BOLT, HEX	F-11-34
		BOLT, HEX, 10X235	F-10-41
		BOLT, HEX, 10X35	F-3-20-32
		BOLT, HEX, 10X60	E-6-20-6
		BOLT, HEX, 10X85	E-6-20-5
		BOLT, HEX, 12X120	E-6-20-3
		BOLT, HEX, 12X130	F-10-46
		BOLT, HEX, 12X200	F-10-39
		BOLT, HEX, 12X45	F-5-13
		BOLT, HEX, 12X45	F-5-1-13
		BOLT, HEX, 12X50	F-3-20-37
		BOLT, HEX, 12X65	E-6-20-4
		BOLT, HEX, 14X180	F-3-20-33
		BOLT, HEX, 5X16	FOP-1-6-69
		BOLT, HEX, 6X14	F-10-42
		BOLT, HEX, 6X16	E-6-10
		BOLT, HEX, 6X16	F-2-27
		BOLT, HEX, 6X55	F-3-26
		BOLT, HEX, 8X28	E-6-9
		BOLT, HEX, 8X35	E-6-8
		BOLT, HEX, 8X35	F-8-10-26
		BOLT, IDLER	E-13-13
		BOLT, OIL CHECK	F-3-10
		BOLT, RECESSED	F-11-31
		BOLT, SEALING, 18MM	E-5-10
		BOLT, SEALING, 22MM	E-3-6
		BOLT, SEALING, 22MM	E-3-39
		BOLT, SEALING, 22MM	E-3-10-12
		BOLT, SEALING, 22MM	E-5-25
		BOLT, SEALING, 6MM	E-18-46
		BOLT, SOCKET(A)	F-11-32
		BOLT, SOCKET(B)	F-11-33
		BOLT, SOCKET, 6X16	F-8-13
		BOLT, SPECIAL ADJUSTER	E-19-22
		BOLT, SPECIAL, 6X12	F-3-20-38
		BOLT, SPECIAL, 6X17	F-3-20-35
		BOLT, SPECIAL, 6X22	F-3-20-36
		BOLT, SPECIAL, 6X220	FOP-5-2
		BOLT, SPECIAL, 6X37	F-3-20-39
		BOLT, SPECIAL, 8MM	E-5-14
		BOLT, SPECIAL, 8X29	E-13-10-8
		BOLT, STUD, 10X170	F-3-17
		BOLT, STUD, 10X45	E-6-10-26
		BOLT, STUD, 12X170	F-3-16
		BOLT, STUD, 12X40	F-3-15
		BOLT, STUD, 6X68	E-19-8
		BOLT, STUD, 8X28	E-14-23
		BOLT, STUD, 8X45	E-14-24
		BOLT, TENSIONER.....	E-19-24
		BOLT, TIMING BELT ADJUSTING SPRING.....	E-13-21
		BOLT, TIMING BELT COVER	E-13-10-7
		BOLT, TIMING BELT IDLER A	E-13-14
		BOLT, WASHER, 6X121	E-6-10-28
		BOLT, WASHER, 8X60	F-4-17
		BOLT-WASHER, 10X109	E-3-29
		BOLT-WASHER, 10X32	F-3-12
		BOLT-WASHER, 10X32	F-10-38
		BOLT-WASHER, 10X47	F-3-13
		BOLT-WASHER, 10X60	E-3-30
		BOLT-WASHER, 10X80	E-3-31
		BOLT-WASHER, 11X105	E-3-32
		BOLT-WASHER, 12X163	E-9-11

BOLT-WASHER, 12X35	E-13-25	CABLE ASSY., SWITCH PANEL	FOP-13-3	CLIP, HARNESS BAND(BLACK)	F-8-10-37
BOLT-WASHER, 16X49	E-13-22	CABLE ASSY., SWITCH PANEL	FOP-13-3	CLIP, HARNESS BAND(BLACK)	FOP-10-3
BOLT-WASHER, 5X18	E-14-10-15	CABLE ASSY., SWITCH PANEL(20FT)		CLIP, INJECTOR	E-14-2
BOLT-WASHER, 5X30	E-15-20	(NHK MEC)	FOP-13-3	CLIP, PISTON PIN	E-7-4
BOLT-WASHER, 6X16	F-2-25	CABLE ASSY., SWITCH PANEL(25FT)		CLIP, ROLLER	FOP-1-7-71
BOLT-WASHER, 6X25	E-15-19	(NHK MEC)	FOP-13-3	CLIP, SENSOR HOSE	E-1-14
BOLT-WASHER, 6X25	F-3-20-31	CABLE ASSY., SWITCH PANEL(30FT)		CLIP, SHIFT WIRE	E-1-15
BOLT-WASHER, 6X25	F-7-10-13	(NHK MEC)	FOP-13-3	CLIP, TUBE	E-6-10-1
BOLT-WASHER, 6X27	E-20-4	CABLE COMP. A, COVER LOCK	F-8-10-12	CLIP, TUBE	E-18-1-1
BOLT-WASHER, 6X27(CT200)	E-20-10-7	CABLE COMP. B, COVER LOCK	F-8-10-13	CLIP, TUBE	E-18-10-11
BOLT-WASHER, 6X27(CT200)	F-7-10-12	CABLE COMP, THROTTLE	E-15-10	CLIP, TUBE(B10)	E-6-10-32
BOLT-WASHER, 6X29	E-6-10-30	CABLE SET, PANEL INDICATOR	FOP-13-1	CLIP, TUBE(B12)	E-1-22
BOLT-WASHER, 8X35	E-18-47	CABLE SET, PANEL INDICATOR	FOP-13-1	CLIP, TUBE(B12)	E-18-1-28
BOSS, FLYWHEEL	E-5-12	CABLE SET, PANEL INDICATOR	FOP-13-1	CLIP, TUBE(B12)	E-18-10-20
BOX ASSY., JUNCTION	F-7-20-1	CAMSHAFT, L	E-9-10-2	CLIP, TUBE(B12.5)	E-6-10-33
BOX ASSY., REMOTE CONTROL		CAMSHAFT, R	E-9-10-1	CLIP, TUBE(B12.5)	E-18-1-29
(NHK MEC)	FOP-1-7-1	CAP COMP, OIL TANK	F-11-30	CLIP, TUBE(B12.5)	F-3-20-47
BOX ASSY., REMOTE CONTROL(EU)	FOP-1-6-1	CAP, BOLT, 10MM	E-3-10-13	CLIP, TUBE(B8)	E-18-1-27
BOX KIT, REMOTE CONTROL	FOP-1-1	CAP, GRIP	FOP-1-7	CLIP, TUBE(B8)	F-10-65
BOX KIT, REMOTE CONTROL	FOP-1-2-1	CAP, GRIP	FOP-1-2-9	CLIP, WIRE	E-18-10-21
BOX KIT, REMOTE CONTROL	FOP-1-4-1	CAP, HANDLE	FOP-1-6-5	CLIP, WIRE HARNESS	E-18-1-32
BRACKET	FOP-1-7-11	CAP, L. SIDE COVER	F-8-10-24	CLIP, WIRE HARNESS	F-7-4
BRACKET A, RR. COVER	F-8-10-8	CAP, OIL(YELLOW)	E-3-10-5	CLIP, WIRE HARNESS	F-7-10-21
BRACKET ASSY.	F-11-6	CAP, RUBBER	FOP-1-7-16	CLIP, WIRE HARNESS	F-7-10-22
BRACKET B, HARNESS CLIP	E-3-22	CAP, SWITCH	FOP-1-8	CLIP, WIRE HARNESS	FOP-10-67
BRACKET B, RR. COVER	F-8-10-9	CAP, TIMING BELT TENSIONER	E-13-8	CLIP, WIRE HARNESS(6.3MM)	FOP-1-6-66
BRACKET C, COUPLER	F-7-10-2	CAP, TROLLING CONTROL SWITCH	FOP-1-7-22	CLIP, WIRE HARNESS, 10MM	E-14-26
BRACKET C, HARNESS CLIP	E-1-12	CAP, UNDER COVER	F-3-20-24	CLIP, WIRE HARNESS, 25MM	E-18-1-31
BRACKET, A.C. GENERATOR FUSE	E-20-10-3	CAP, WATER JOINT	F-3-20-4	CLIP, WIRE HARNESS, 25MM	E-20-10-10
BRACKET, BUZZER	FOP-7-17	CARTRIDGE, OIL FILTER	E-3-10-4	CLIP, WIRE HARNESS, 25MM	F-3-20-49
BRACKET, BUZZER	FOP-7-1-14	CASE ASSY., GEAR(L)	F-3-10-1	CLUTCH COMP., OVERRUNNING	E-21-3
BRACKET, CABLE	F-8-10-1	CASE ASSY., GEAR(XL)	F-3-10-1	CLUTCH COMP., OVERRUNNING	E-21-3
BRACKET, CLIP B	E-1-11	CASE ASSY., GEAR(XL)	F-3-10-1	COCK ASSY., FUEL DRAIN	E-18-1-24
BRACKET, CLIP B	E-3-21	CASE ASSY., GEAR(XXL)	F-3-10-1	COIL COMP., PLUG HOLE	E-20-2
BRACKET, COUPLER D	E-13-18	CASE ASSY., GEAR(XXL)	F-3-10-1	COLLAR	E-18-26
BRACKET, ECU	E-20-10-5	CASE ASSY., OIL SEAL	E-3-2	COLLAR, 6.2X10X25.5	F-3-20-52
BRACKET, FR	E-21-10	CASE COMP., GEAR	F-3-27	COLLAR, 8.5X14.5	E-18-56
BRACKET, FR. COVER	F-8-10-5	CASE COMP., MOUNT	E-6-10-22	COLLAR, 8.5X14.5	F-8-10-38
BRACKET, HARNESS CLIP A	E-14-17	CASE COMP., PUMP	E-18-27	COLLAR, C.D.I. UNIT CASE	E-15-26
BRACKET, HOOK	F-8-4	CASE KIT, GEAR	FOP-12-1	COLLAR, C.D.I. UNIT CASE	E-20-5
BRACKET, L. SIDE COVER	F-8-10-7	CASE, ELECTRONIC PARTS	E-20-10-1	COLLAR, C.D.I. UNIT CASE	E-20-10-11
BRACKET, L. STERN	F-10-25	CASE, EXTENSION	F-3-20-10	COLLAR, C.D.I. UNIT CASE	F-7-10-25
BRACKET, LINK JOINT	FOP-1-6-19	CASE, EXTENSION	F-3-20-10	COLLAR, DISTANCE	F-4-33
BRACKET, NEUTRAL SWITCH	F-2-19	CASE, FLUSH VALVE	E-6-10-7	COLLAR, DISTANCE(A)	FOP-5-3
BRACKET, R. SIDE COVER	F-8-10-6	CASE, GEAR	F-3-3	COLLAR, DISTANCE(B)	FOP-5-4
BRACKET, R. STERN	F-10-24	CASE, POWER TILT RELAY	F-7-10-11	COLLAR, DISTANCE, 6.5X9X3	F-8-16
BRACKET, REMOTE CONTROL		CASE, SWIVEL	F-10-20	COLLAR, DISTANCE, 6.5X9X5	F-3-20-52
HOUSING	FOP-1-12	CASE, SWIVEL	F-10-20	COLLAR, DISTANCE, 6X10.5X25	F-3-20-53
BRACKET, REMOTE CONTROL		CIRCLIP, EXTERNAL, 15MM	F-5-31	COLLAR, DISTANCE, 6X10X43.5	FOP-1-6-68
HOUSING	FOP-1-2-13	CIRCLIP, EXTERNAL, 15MM	F-5-1-34	COLLAR, LINK JOINT	FOP-1-6-67
BRACKET, RR	E-21-11	CIRCLIP, EXTERNAL, 39MM	F-10-66	COLLAR, LOWER CYLINDER	F-10-33
BRACKET, SENSOR CORD	E-14-10-8	CIRCLIP, INTERNAL	F-11-38	COLLAR, LOWER CYLINDER	F-10-33
BRACKET, SHIFT LINK	F-2-16	CIRCLIP, INTERNAL, 43	F-3-20-48	COLLAR, LOWER CYLINDER	F-10-33
BRACKET, SOLENOID VALVE	E-1-6	CIRCLIP, INTERNAL, 47MM	F-4-37	COLLAR, MOUNTING(6MM)	F-7-10-23
BRACKET, TILTING	F-10-28	CLAMP	F-6-5	COLLAR, ORIFICE	F-11-50
BRACKET, WIRE CLAMP	FOP-1-7-15	CLAMP	F-6-8	COLLAR, SET	E-18-23
BREAKER ASSY.	F-11-1	CLAMP, CHECK VALVE	E-18-10-2	COLLAR, SHIFT SLIDER	F-2-11
BRUSH ASSY.	F-11-2	CLAMP, FUEL TUBE	E-18-10-22	COLLAR, SLIDING PLATE	FOP-1-6-16
BRUSH SET	E-21-7	CLAMP, HARNESS	FOP-1-6-9	COLLAR, STEERING ROD	F-10-71
BRUSH SET	E-21-7	CLAMP, HOSE	E-18-10-10	COLLAR, TIMING BELT COVER	E-13-10-10
BUFFER, PLATE	E-18-1-6	CLAMP, POWER TILT CORD	FOP-1-6-31	CONTROL UNIT, ELECTRONIC	E-20-10-4
BUSH A, COVER LOCK	F-8-10-15	CLAMP, TUBE	F-10-21	CONTROL UNIT, ELECTRONIC	E-20-10-4
BUSH A, THRUST RECEIVE	F-10-31	CLAMP, TUBE(D10.5)	E-4-20	CORD ASSY., INDICATOR(20FT)	FOP-13-2
BUSH B, COVER LOCK	F-8-10-16	CLAMP, TUBE(D10.5)	E-18-10-25	CORD ASSY., INDICATOR(25FT)	FOP-13-2
BUSH B, THRUST RECEIVE	F-10-32	CLAMP, TUBE(D10.7)	E-18-10-19	CORD ASSY., INDICATOR(30FT)	FOP-13-2
BUSH COMP., VERTICAL SHAFT	F-3-20-12	CLAMP, TUBE(D21)	E-4-22	CORD COMP., EMERGENCY	FOP-1-6-42
BUSH, INSULATION	E-19-4	CLAMP, TUBE(D29)	E-4-21	CORD COMP., EMERGENCY	FOP-1-7-38
BUSH, INSULATION	E-19-18	CLAMP, TUBE(D32.5)	E-1-21	CORD COMP., EMERGENCY	FOP-7-11
BUSH, LOWER CYLINDER	F-11-27	CLAMP, WIRE, 8MM	E-18-1-30	CORD COMP., EMERGENCY	FOP-7-1-9
BUSH, MOTOR CODE	F-11-21	CLAMPER, SENSOR TUBE	F-10-12	CORD, A.C. GENERATOR	F-7-10-8
BUSH, SHIFT ARM	F-2-15	CLIP A, WIRE	E-1-13	CORD, SWITCH	E-3-23
BUSH, SWIVEL CASE	F-10-23	CLIP D, SPEEDOMETER CABLE	E-14-18	COTTER, VALVE(FUJI VALVE)	E-9-10-17
BUSH, SWIVEL CASE	F-11-12	CLIP D, WASHER TUBE	E-1-28	COVER ASSY.	FOP-1-4-11
BUSH, TILT ARM	F-10-27	CLIP, 10.7MM	F-11-37	COVER ASSY., COOLING FAN	E-15-29
BUTTON, THROTTLE	FOP-1-9	CLIP, BRAKE PIPE	F-2-21	COVER ASSY., CRANKCASE UPPER	E-3-1
BUTTON, THROTTLE	FOP-1-2-10	CLIP, DETENT	FOP-1-7-9	COVER ASSY., ENGINE	F-8-2
BUTTON, THROTTLE	FOP-1-4-8	CLIP, EMERGENCY LOCK	FOP-1-6-43	COVER ASSY., ENGINE	F-8-2
BUZZER COMP., WARNING	FOP-1-6-46	CLIP, EMERGENCY LOCK	FOP-7-12	COVER ASSY., ENGINE	F-8-2
BUZZER COMP., WARNING	FOP-1-7-41	CLIP, EMERGENCY LOCK	FOP-7-1-10	COVER ASSY., L. TIMING BELT	E-13-10-3
BUZZER COMP., WARNING	FOP-7-16	CLIP, HARNESS	E-1-23	COVER ASSY., R. TIMING BELT	E-13-10-2
BUZZER COMP., WARNING	FOP-7-1-13	CLIP, HARNESS	E-18-54	COVER B, TERMINAL	F-7-10-6
<C>		CLIP, HARNESS	F-8-10-36	COVER B, TERMINAL(L)	F-7-10-5
CABLE ASSY., POWER TILT RELAY	F-7-10-7	CLIP, HARNESS BAND(BLACK)	E-3-50	COVER COMP.	E-18-4
CABLE ASSY., REMOTE CONTROL(B)	FOP-1-6-34	CLIP, HARNESS BAND(BLACK)	E-13-10-11	COVER COMP., FUSE	F-7-20-2
CABLE ASSY., REMOTE CONTROL(B)	FOP-1-7-30	CLIP, HARNESS BAND(BLACK)	F-2-41	COVER COMP., INTAKE MANIFOLD	E-14-10-5
CABLE ASSY., STARTER	F-7-10-3	CLIP, HARNESS BAND(BLACK)	F-7-5	COVER COMP., L. UNDER ENGINE	F-3-20-21
CABLE ASSY., SWITCH PANEL	FOP-13-3	CLIP, HARNESS BAND(BLACK)	F-7-10-24	COVER COMP., L. UNDER ENGINE	F-3-20-21

COVER COMP., L. UNDER ENGINE.....	F-3-20-21	FILTER B.....	F-11-19	HOLDER ASSY., BRUSH.....	E-19-1
COVER COMP., R. UNDER ENGINE.....	F-3-20-20	FLOAT.....	E-18-1-15	HOLDER COMP., BRUSH.....	E-21-9
COVER COMP., R. UNDER ENGINE.....	F-3-20-20	FLOAT SET.....	E-18-2	HOLDER COMP., BRUSH.....	E-21-9
COVER COMP., R. UNDER ENGINE.....	F-3-20-20	FLYWHEEL COMP.....	E-5-11	HOLDER, BEARING.....	F-5-12
COVER, BEARING.....	E-19-5	FRAME COMP., MOUNTING(L).....	F-10-13	HOLDER, NEUTRAL LOCK.....	FOP-1-4-14
COVER, DRAIN PLUG(L).....	F-3-20-13	FRAME COMP., MOUNTING(XL).....	F-10-13	HOLDER, NEUTRAL LOCK.....	FOP-1-7-20
COVER, DRAIN PLUG(XL).....	F-3-20-13	FUSE, BLOCK(150A).....	F-7-20-3	HOLDER, OIL FILTER.....	E-3-10-7
COVER, DUAL GRIP.....	FOP-1-2-8	FUSE, MINI(10A).....	F-7-20-9	HOLDER, PROPELLER SHAFT.....	F-5-11
COVER, FLUSH VALVE.....	E-6-10-6	FUSE, MINI(15A).....	F-7-20-10	HOLDER, PROPELLER SHAFT.....	F-5-1-11
COVER, FR.....	F-8-6	FUSE, MINI(30A).....	F-7-20-11	HOLDER, ROD(A).....	F-8-20-3
COVER, FR. SEPARATE.....	F-3-20-9	<G>		HOLDER, SEAL.....	F-2-17
COVER, GEAR CASE.....	F-3-5	GASKET B, IMPELLER.....	F-4-5	HOLDER, SHIFT ROD.....	F-4-12
COVER, GRIP.....	FOP-1-4-4	GASKET COMP., CYLINDER HEAD.....	E-9-9	HOLDER, STRIKER.....	F-8-10-21
COVER, IMPELLER.....	F-4-4	GASKET, EAC VALVE.....	E-15-5	HOSE A, PRESSURE REGULATOR.....	
COVER, L. CAMSHAFT THRUST.....	E-9-8	GASKET, EX. PIPE.....	E-6-4	RETURN.....	E-18-10-13
COVER, L. CYLINDER HEAD.....	E-1-3	GASKET, FR. INJECTOR BASE.....	E-14-12	HOSE B, PRESSURE REGULATOR.....	
COVER, L. GRIP.....	FOP-1-5	GASKET, INTAKE MANIFOLD.....	E-14-15	RETURN.....	E-18-10-14
COVER, L. GRIP.....	FOP-1-2-6	GASKET, INTAKE MANIFOLD.....	E-14-10-1	HOSE COMP., FUEL.....	E-14-9
COVER, L. LOWER MOUNTING(L).....	F-3-20-27	GASKET, L. EX. MANIFOLD.....	E-4-5	HOSE COMP., FUEL JOINT.....	E-14-10
COVER, L. LOWER MOUNTING(XL).....	F-3-20-27	GASKET, MOUNT CASE.....	E-6-20-1	HOUSING ASSY., L. INNER.....	FOP-1-3
COVER, L. RELIEF VALVE.....	E-6-10-17	GASKET, R. EX. MANIFOLD.....	E-4-3	HOUSING ASSY., L. INNER.....	FOP-1-2-3
COVER, L. WATER JACKET.....	E-6-10-21	GASKET, RR. INJECTOR BASE.....	E-14-14	HOUSING ASSY., R. INNER.....	FOP-1-2-4
COVER, LEVER.....	FOP-1-7-6	GASKET, THROTTLE BODY.....	E-15-2	HOUSING ASSY., R. INNER.....	FOP-1-4-2
COVER, LOCK ARM.....	FOP-1-4-6	GAUGE COMP., OIL LEVEL.....	E-3-15	HOUSING COMP.,.....	
COVER, NEUTRAL SWITCH.....	F-2-20	GEAR ASSY., INTERNAL.....	E-21-16	REMOTE CONTROL BOX.....	FOP-1-13
COVER, OIL LEVEL GAUGE.....	E-3-16	GEAR ASSY., INTERNAL.....	E-21-24	HOUSING COMP.,.....	
COVER, OIL PUMP.....	E-5-4	GEAR ASSY., PLANETARY.....	E-21-4	REMOTE CONTROL BOX(A).....	FOP-1-6-10
COVER, PLUG MAINTENANCE.....	F-3-20-19	GEAR ASSY., SHIFT.....	FOP-1-7-23	HOUSING COMP.,.....	
COVER, POWER TRIM-TILT WIRE.....	FOP-1-7-18	GEAR COMP., BEVEL(FORWARD).....	F-5-8	REMOTE CONTROL BOX(B).....	FOP-1-6-11
COVER, POWER TRIM-TILT WIRE.....	FOP-1-7-74	GEAR COMP., BEVEL(REVERSE).....	F-5-1-9	HOUSING COMP.,.....	
COVER, PUMP.....	E-18-28	GEAR, BEVEL(FORWARD)(24T).....	F-5-1-8	REMOTE CONTROL BOX(DUAL).....	FOP-1-2-14
COVER, PUMP(A).....	E-18-29	GEAR, BEVEL(REVERSE)(24T).....	F-5-9	HOUSING, FR.....	FOP-1-7-12
COVER, R. CAMSHAFT THRUST.....	E-9-7	GEAR, DRIVE.....	FOP-1-7-24	HOUSING, IMPELLER.....	F-4-2
COVER, R. CYLINDER HEAD.....	E-1-1	GEAR, PINION.....	F-4-16	HOUSING, LEAD.....	FOP-1-14
COVER, R. LOWER MOUNTING(L).....	F-3-20-26	GEAR, PINION(COUNTER ROTATION).....	F-4-16	HOUSING, LEAD.....	FOP-1-2-15
COVER, R. LOWER MOUNTING(XL).....	F-3-20-26	GENERATOR ASSY., A.C.....	E-19-14	HOUSING, LOWER CENTER MOUNTING.....	F-10-17
COVER, R. RELIEF VALVE.....	E-6-10-13	GENERATOR ASSY., A.C.....	E-19-14	HOUSING, LOWER CENTER MOUNTING.....	F-10-17
COVER, R. WATER JACKET.....	E-6-10-19	GRIP.....	FOP-1-7-5	HOUSING, LOWER MOUNTING.....	F-3-20-16
COVER, STARTER TERMINAL.....	F-7-10-4	GRIP, REMOTE CONTROL HANDLE.....	FOP-1-6	HOUSING, REMOTE CONTROL BOX(C).....	FOP-1-6-12
COVER, THERMOSTAT.....	E-4-13	GRIP, REMOTE CONTROL HANDLE.....	FOP-1-2-7	HOUSING, RR.....	FOP-1-7-13
COVER, UPPER MOUNT.....	F-10-18	GRIP, REMOTE CONTROL HANDLE.....	FOP-1-6-4	HOUSING, UPPER MOUNTING.....	F-10-14
COVER, WATER JACKET.....	E-18-12	GRIP, SCREW DRIVER.....	F-13-16	HOUSING, WATER PUMP.....	F-4-6
CRANKCASE COMP.....	E-3-10-1	GROMMET A, UNDER CASE.....	F-8-10-3	<I>	
CRANKSHAFT COMP.....	E-7-9	GROMMET, AIR CLEANER CASE.....	F-8-1	IDLER B, TIMING BELT.....	E-13-15
CUP.....	E-18-1-16	GROMMET, ELECTRONIC PARTS CASE.....	E-20-1	IDLER, TIMING BELT(KOYO SEIKO).....	E-13-12
CUP SET, WATER SEPARATOR.....	E-18-1-5	GROMMET, ELECTRONIC PARTS CASE.....	E-20-10-2	IMPELLER, PUMP.....	F-4-1
<D>		GROMMET, ELECTRONIC PARTS CASE.....	F-7-10-1	INJECTOR ASSY., FUEL.....	E-14-1
DAMPER, HOOK.....	F-8-5	GROMMET, EXTENSION CASE.....	F-4-13	INSULATOR.....	E-18-31
DOWEL PIN, 10X12.....	E-14-30	GROMMET, GEAR CASE.....	F-3-4	INSULATOR COMP.....	E-18-30
DOWEL PIN, 13X37.....	E-3-41	GROMMET, L. IDLE PORT.....	F-3-20-29	<J>	
DOWEL PIN, 13X37.....	E-3-41	GROMMET, L. IDLE PORT.....	F-3-20-29	JOINT A, VACUUM TUBE.....	E-14-10-7
DOWEL PIN, 14X15.....	E-5-15	GROMMET, L. IDLE PORT.....	F-3-20-57	JOINT ASSY (INLET).....	F-6-2
DOWEL PIN, 14X15.....	E-6-20-9	GROMMET, POWER TILT SWITCH.....	F-3-20-8	JOINT ASSY (OUTLET).....	F-6-3
DOWEL PIN, 16X22.....	E-9-15	GROMMET, R. IDLE PORT.....	F-3-20-28	JOINT ASSY., OIL PIPE.....	E-3-12
DOWEL PIN, 5X8.....	E-3-54	GROMMET, R. IDLE PORT.....	F-3-20-28	JOINT B, WASHER TUBE(MITSUBA).....	F-10-8
DOWEL PIN, 6X10.....	E-3-53	GROMMET, R. IDLE PORT.....	F-3-20-56	JOINT SET.....	E-18-6
DOWEL PIN, 6X10.....	E-9-14	GROMMET, RELAY.....	F-7-10-10	JOINT, DRIVE.....	F-11-16
DOWEL PIN, 6X10.....	E-9-18	GROMMET, RELAY BRACKET.....	E-20-10-6	JOINT, FUEL PIPE.....	E-14-8
DOWEL PIN, 6X10.....	E-13-30	GROMMET, SILENCER.....	E-15-9	JOINT, FUEL PIPE.....	E-18-38
DOWEL PIN, 6X10.....	E-15-28	GROMMET, TIMING BELT COVER.....	E-13-10-1	JOINT, FUEL RETURN.....	E-18-10-12
DOWEL PIN, 6X10.....	F-3-24	GROMMET, UNDER CASE.....	E-15-18	JOINT, FUEL TUBE.....	F-8-20-5
DOWEL PIN, 6X10.....	F-3-24	GROMMET, UNDER CASE(C).....	F-3-20-7	JOINT, WATER HOSE.....	F-3-20-2
DOWEL PIN, 6X10.....	F-3-20-50	GROMMET, UNDER CASE(C).....	F-11-10	<K>	
DOWEL PIN, 6X10.....	F-4-24	GROMMET, VAPOR SEPARATOR.....	E-18-34	KEY, 4.5X24.....	E-13-28
DOWEL PIN, 8X14.....	E-3-10-18	GROMMET, VAPOR SEPARATOR.....	E-18-35	KEY, SPECIAL.....	E-13-29
DRIVER 3, MINUS SCREW(NO.2).....	F-13-15	GROMMET, WATER CHECK.....	F-3-20-30	KEY, WOODRUFF.....	F-4-23
DRUM ASSY., FREE THROTTLE.....	FOP-1-7-26	GROMMET, WATER TUBE.....	E-6-6	KIT, CABLE(NMEA)(6FT).....	FOP-10-1
<E>		GROMMET, WIRE(14).....	FOP-1-7-21	<L>	
END COVER, RR.....	E-19-17	GUIDE COMP., ROD.....	F-11-52	LABEL, FUSE & OIL CAUTION.....	F-12-2
END, NIPPLE.....	F-10-10	GUIDE, EX. VALVE(OS).....	E-9-3	LABEL, SIGP.....	FOP-1-7-45
E-RING, 10MM.....	F-4-34	GUIDE, IN. VALVE(OS).....	E-9-2	LABEL, WARNING OPERATOR.....	F-12-8
E-RING, 12MM.....	F-2-43	GUIDE, L. EX.....	E-6-10-5	LAMP ASSY., INDICATION.....	FOP-1-6-44
E-RING, 15MM.....	F-11-51	GUIDE, R. EX.....	E-6-10-2	LAMP ASSY., INDICATION.....	FOP-1-7-39
E-RING, 3MM.....	FOP-1-6-78	<H>		LAMP ASSY., INDICATION(4-LED).....	FOP-7-14
E-RING, 4MM.....	F-2-42	HANDLE, REMOTE CONTROL.....	FOP-1-4	LAMP ASSY., INDICATION(4-LED).....	FOP-7-1-11
E-RING, 4MM.....	FOP-1-6-79	HANDLE, REMOTE CONTROL.....	FOP-1-2-5	LEVER SET.....	E-21-18
E-RING, 6MM.....	F-8-10-39	HANDLE, REMOTE CONTROL.....	FOP-1-4-3	LEVER, COVER LOCK.....	F-8-10-14
E-RING, 6MM.....	FOP-1-36	HANDLE, REMOTE CONTROL.....	FOP-1-6-2	LEVER, FREE THROTTLE.....	FOP-1-7-28
E-RING, 6MM.....	FOP-1-2-41	HANGER, ENGINE.....	E-3-10-2	LEVER, HAND.....	FOP-1-7-3
E-RING, 6MM.....	FOP-1-4-28	HANGER, ENGINE.....	E-9-1	LEVER, HANDLE LOCK.....	FOP-1-6-3
E-RING, 6MM (LOOSE PARTS).....	FOP-1-7-65	HARNASS ASSY., MAIN EIRE.....	F-7-1	LEVER, IDLE.....	FOP-1-6-22
E-RING, 7MM.....	FOP-1-6-80	HARNASS ASSY., SWITCH PANEL.....	FOP-7-6	LEVER, PUMP.....	F-4-3
EXTENSION, OIL FILLER.....	E-3-10-6	HARNASS ASSY., SWITCH PANEL.....	FOP-7-1-4	LINER, SWIVEL CASE.....	F-10-22
<F>		HARNASS COMP.....	E-18-41	LOCK ASSY., FR.....	F-8-10-22
FAN, COOLING.....	E-13-16	HEAD COMP., CYLINDER.....	E-9-5	LOCK COMP., SIDE.....	F-8-10-23
FILTER.....	E-18-1-12	HOLDER.....	E-18-11	LOW PERMEATION HOSE L=1600.....	F-6-7
FILTER ASSY., SPOOL VALVE.....	E-3-19	HOLDER ASSY., BEARING.....	F-5-1-37	LOW PERMEATION HOSE L=700.....	F-6-6

PROPELLER COMP., THREE BLADES	FOP-8-1	SCREW, PAN, 4X10	FOP-1-26	SENSOR ASSY., WATER TEMPERATURE	E-4-15
PROPELLER COMP., THREE BLADES	FOP-8-1	SCREW, PAN, 4X10	FOP-1-2-29	SENSOR COMP., KNOCK	E-3-20
PULLER, MINI FUSE	F-7-20-4	SCREW, PAN, 5X10	FOP-1-2-3	SENSOR COMP., TDC1-TDC2	E-13-10-6
PULLEY	E-19-6	SCREW, PAN, 5X10	FOP-1-2-26	SENSOR, OXYGEN	E-4-14
PULLEY COMP., L. TIMING BELT DRIVEN	E-13-5	SCREW, PAN, 5X10	FOP-1-6-70	SEPARATOR ASSY., VAPOR	E-18-33
PULLEY COMP., R. TIMING BELT DRIVEN	E-13-4	SCREW, PAN, 5X12	E-18-1-14	SEPARATOR ASSY., WATER	E-18-1-4
PULLEY, CRANKSHAFT	E-13-3	SCREW, PAN, 5X16	FOP-1-2-2	SEPARATOR, EXTENSION	F-3-2
PULLEY, TIMING BELT DRIVE	E-13-1	SCREW, PAN, 5X16	FOP-1-2-25	SHAFT ASSY., CLUTCH	E-21-13
PUMP ASSY.	F-11-14	SCREW, PAN, 5X16	FOP-1-4-20	SHAFT ASSY., CLUTCH	E-21-13
PUMP ASSY., FUEL	E-1-7	SCREW, PAN, 5X18	FOP-1-2-5	SHAFT ASSY., GEAR	E-21-15
PUMP ASSY., OIL	E-5-1	SCREW, PAN, 5X18	FOP-1-2-28	SHAFT ASSY., GEAR	E-21-15
PUMP KIT, IMPELLER	F-4-35	SCREW, PAN, 5X20	FOP-1-24	SHAFT COMP., EX. ROCKER ARM	E-9-10-8
PUMP KIT, IMPELLER	F-4-36	SCREW, PAN, 5X20	FOP-1-2-27	SHAFT COMP., INTAKE ROCKER ARM	E-9-10-7
PUMP UNIT SET A, FUEL	E-18-7	SCREW, PAN, 5X30	FOP-1-4-22	SHAFT COMP., SHIFT(A)	F-2-8
PUMP UNIT SET B, FUEL	E-18-9	SCREW, PAN, 5X40	FOP-1-28	SHAFT COMP., SHIFT(B)	F-2-14
PUMP UNIT, FUEL	E-18-37	SCREW, PAN, 5X40	FOP-1-2-31	SHAFT, COVER OPEN	F-8-10-19
<R>		SCREW, PAN, 5X40	FOP-6-3	SHAFT, FR. LOCK	F-8-10-20
RECEIVER, THRUST	F-10-30	SCREW, PAN, 5X40	FOP-7-18	SHAFT, PROPELLER	F-5-10
RECTIFIER ASSY.	E-19-19	SCREW, PAN, 5X40	FOP-7-1-15	SHAFT, PROPELLER	F-5-1-10
REGULATOR ASSY.	E-19-20	SCREW, PAN, 5X55	FOP-1-2-32	SHAFT, THROTTLE BUTTON	FOP-1-4-9
REGULATOR ASSY., PRESSURE	E-14-6	SCREW, PAN, 5X65	FOP-1-34	SHAFT, TILTING	F-10-26
RELAY ASSY., FUEL PUMP(DENSO)	F-7-20-5	SCREW, PAN, 5X65	FOP-1-2-39	SHAFT, VERTICAL(L)	F-4-14
RELAY ASSY., POWER TILT	F-7-10-9	SCREW, PAN, 5X8	E-21-22	SHAFT, VERTICAL(XL)	F-4-14
RELAY ASSY., POWER(12V-20A)	F-7-20-6	SCREW, PAN, 6X10	FOP-1-6-51	SHAFT, VERTICAL(XXL)	F-4-14
RETAINER, SPRING	E-7-13	SCREW, PAN, 6X18	E-4-26	SHIFTER, CLUTCH	F-5-1
RETAINER, VALVE SPRING	E-9-10-15	SCREW, PAN, 6X18	FOP-1-27	SHIFTER, CLUTCH	F-5-1-1
RING	E-18-32	SCREW, PAN, 6X18	FOP-1-2-30	SHIM A, BEVEL(0.10)	F-5-18
RING SET, PISTON(0.25)(RIKEN)	E-7-1	SCREW, PAN, 6X22	E-21-21	SHIM A, BEVEL(0.10)	F-5-1-18
RING SET, PISTON(STD.)(RIKEN)	E-7-1	SCREW, PAN, 6X22(SPECIAL)	E-21-21	SHIM A, BEVEL(0.10)	F-5-1-19
RING, BACK UP	F-11-20	SCREW, PAN, 6X25	F-3-20-40	SHIM A, GEAR(0.10)	F-4-22
RING, CROSS PIN	F-5-3	SCREW, PAN, 6X35	FOP-1-4-23	SHIM A, THRUST(2.75)	F-5-19
RING, CROSS PIN	F-5-1-3	SCREW, PAN, 6X8	F-10-44	SHIM B, BEVEL(0.15)	F-5-18
RING, INNER(15X20X23)	F-2-37	SCREW, PAN, 6X8	F-10-77	SHIM B, BEVEL(0.15)	F-5-1-18
RING, SETTING(39)	F-5-21	SCREW, PAN, 6X8	F-11-35	SHIM B, BEVEL(0.15)	F-5-1-19
RING, STOPPER	F-2-7	SCREW, RIVET, 5X10	F-10-45	SHIM B, GEAR(0.15)	F-4-22
RING, WATER TUBE SEAL	F-4-8	SCREW, RIVET, 5X10	F-11-36	SHIM B, THRUST(2.80)	F-5-19
ROD COMP. A, SHIFT(L)	F-4-11	SCREW, SPECIAL, 6X35	F-3-20-34	SHIM C, BEVEL(0.30)	F-5-18
ROD COMP. A, SHIFT(XL)	F-4-11	SCREW, TAPPET ADJUSTING	E-9-10-12	SHIM C, BEVEL(0.30)	F-5-1-18
ROD COMP. A, SHIFT(XXL)	F-4-11	SCREW, TAPPING, 4X10	F-8-17	SHIM C, BEVEL(0.30)	F-5-1-19
ROD COMP., CONNECTING	E-7-7	SCREW, TAPPING, 5X10	FOP-1-6-72	SHIM C, GEAR(0.30)	F-4-22
ROD COMP., PISTON	F-11-53	SCREW, TAPPING, 5X12	FOP-1-6-73	SHIM C, THRUST(2.85)	F-5-19
ROD COMP., PISTON(B)	F-11-15	SCREW, TAPPING, 5X25	FOP-1-6-75	SHIM D, BEVEL(0.50)	F-5-18
ROD COMP., SHIFT	F-4-9	SCREW, TAPPING, 5X8	FOP-1-6-71	SHIM D, BEVEL(0.50)	F-5-1-18
ROD COMP., SHIFT	F-4-9	SCREW, TAPPING, 6X16	FOP-1-6-74	SHIM D, BEVEL(0.50)	F-5-1-19
ROD KIT, STEERING	F-10-3	SCREW, TAPPING, 6X30	FOP-1-4-24	SHIM D, GEAR(0.50)	F-4-22
ROD, LINK	F-2-10	SCREW, TRUSS, 4X12	FOP-1-4-21	SHIM D, THRUST(2.90)	F-5-19
ROLLER	FOP-1-7-67	SCREW, WASHER	E-18-22	SHIM E, THRUST(2.95)	F-5-19
ROLLER, 3X13.8	F-5-28	SCREW, WAVE WASHER	E-19-12	SHIM F, THRUST(3.00)	F-5-19
ROLLER, 3X13.8	F-5-1-31	SCREW, WAVE WASHER	E-19-13	SHIM G, THRUST(3.05)	F-5-19
ROLLER, 5X8	E-5-24	SCREW-WASHER	E-18-20	SHIM H, THRUST(3.10)	F-5-19
ROLLER, CLICK	FOP-1-6-65	SCREW-WASHER	E-19-11	SHIM I, THRUST(2.70)	F-5-19
ROLLER, DRIVE GEAR CAM	FOP-1-7-66	SCREW-WASHER, 5X15	F-7-20-8	SHIM J, THRUST(2.65)	F-5-19
ROLLER, FREE THROTTLE	FOP-1-7-70	SCREW-WASHER, 6X40	F-3-20-40	SHIM K, THRUST(2.60)	F-5-19
ROTOR ASSY.	E-19-15	SEAL A, COVER UNDER	F-3-20-22	SHIM L, THRUST(2.55)	F-5-19
ROTOR COMP.	E-21-2	SEAL A, VALVE STEM(NOK)	E-9-4	SHIM M, THRUST(2.50)	F-5-19
ROTOR, OIL PUMP INNER	E-5-5	SEAL B, COVER UNDER	F-3-20-23	SLIDER COMP., SHIFT	F-5-4
ROTOR, OIL PUMP OUTER	E-5-6	SEAL B, EX. GUIDE	E-6-10-4	SLIDER COMP., SHIFT	F-5-1-4
RUBBER C, STAND STOPPER	F-3-20-55	SEAL B, VALVE STEM(NOK)	E-9-6	SLIDER, SHIFT	F-5-5
RUBBER, DRAIN PLUG	F-3-20-11	SEAL C, UNDER COVER	F-3-20-25	SLIDER, SHIFT	F-5-1-5
RUBBER, FR. CARRIER CUSHION	F-8-10-11	SEAL D, UNDER COVER	F-8-10-25	SLINGER, OIL	F-4-15
RUBBER, MOUNT CASE SEAL	E-6-10-23	SEAL, ENGINE COVER	F-8-3	SPACER KIT, REMOTE CONTROL BOX	FOP-1-2
RUBBER, OIL PUMP	E-5-3	SEAL, EXHAUST GUIDE	E-6-10-3	SPACER KIT, REMOTE CONTROL BOX	FOP-1-2-2
RUBBER, RING	E-4-11	SEAL, L. IDOL PORT	F-3-20-15	SPACER(1)(LOOSE PARTS)	FOP-1-7-10
RUBBER, STOPPER	F-8-10-10	SEAL, L. IDOL PORT	F-3-20-15	SPACER(2)(LOOSE PARTS)	FOP-1-7-64
RUBBER, UPPER MOUNT STOPPER	F-10-16	SEAL, R. IDOL PORT	F-3-20-14	SPACER, CABLE CLAMP	FOP-1-17
<S>		SEAL, R. IDOL PORT	F-3-20-14	SPACER, CABLE CLAMP	FOP-1-2-18
SCREEN COMP., FUEL STRAINER	E-18-39	SEAL, RUBBER	FOP-1-7-19	SPACER, CABLE CLAMP	FOP-1-4-13
SCREEN, L. WATER	F-3-7	SEAL, SPARK PLUG TUBE(NOK)	E-1-4	SPACER, CABLE CLAMP	FOP-1-6-33
SCREEN, R. WATER	F-3-6	SEAL, UPPER MOUNT COVER	F-10-19	SPACER, CLICK SPRING	FOP-1-6-27
SCREW	E-3-51	SEAL, WATER	F-11-48	SPACER, INTAKE MANIFOLD	E-14-16
SCREW	E-3-52	SEAL, WATER(14X26X8)	F-2-39	SPACER, L. RELIEF VALVE	E-6-10-18
SCREW	E-19-9	SEAL, WATER, 12X21X6	F-4-28	SPACER, NEUTRAL SWITCH	FOP-1-6-30
SCREW	E-19-10	SEAL, WATER, 12X21X6	FOP-12-5	SPACER, R. RELIEF VALVE	E-6-10-12
SCREW SET	E-15-1	SEAL, WATER, 22X35X7	E-6-10-35	SPACER, REMOTE CONTROL BOX	FOP-1-6-26
SCREW SET, DRAIN	E-18-5	SEAL, WATER, 26X42X7	F-4-27	SPACER, THERMOSTAT COVER	E-4-12
SCREW SET, DRAIN	E-18-1-34	SEAL, WATER, 26X42X7	FOP-12-3	SPACER, THROTTLE BODY	E-15-4
SCREW, 4X10	FOP-1-7-49	SEAL, WATER, 30X45X7	F-5-29	SPRING COMP., CLICK	F-2-5
SCREW, 4X6	FOP-1-7-47	SEAL, WATER, 30X45X7	F-5-1-32	SPRING COMP., CLICK	F-10-4
SCREW, 5X10	FOP-1-7-48	SEAL, WATER, 30X45X7	FOP-12-4	SPRING COMP., TIMING BELT	
SCREW, 5X12	FOP-1-7-50	SEAT, SPRING(250)	E-7-14	ADJUSTING	E-13-9
SCREW, 5X18	FOP-1-7-46	SEAT, VALVE SPRING	E-9-10-16	SPRING(1)	FOP-1-7-27
SCREW, 6X90(LOOSE PARTS)	FOP-1-7-51	SEAT, WATER MOUTH	F-3-20-3	SPRING(2)	FOP-1-7-8
SCREW, 6X95	FOP-1-6-53	SENSOR ASSY., AIR TEMP.	E-15-16	SPRING, ACCELERATOR WHEEL	FOP-1-6-21
SCREW, FLAT, 5X12	FOP-1-6-52	SENSOR ASSY., CRANK	E-3-27	SPRING, AIR FLOW TUBE	E-15-7
SCREW, FLAT, 5X55	F-3-11	SENSOR ASSY., MAP	E-14-10-12	SPRING, CHOKE RETURN	FOP-1-6-25
SCREW, FLAT, 6X16	E-5-19	SENSOR ASSY., TRIM ANGLE	F-10-7	SPRING, CLICK ASSIST.	F-2-6
SCREW, PAN	E-18-21	SENSOR ASSY., WATER TEMPERATURE	E-3-26	SPRING, CLICK ASSIST.	F-10-5

SPRING, COVER LOCK HOOK	F-8-10-17	TRIM METER ASSY	FOP-3-1	WASHER, PLAIN, 12MM	E-6-20-7
SPRING, DETENT	FOP-1-7-29	TRIM-TILT ASSY., POWER	F-11-13	WASHER, PLAIN, 12MM	F-3-22
SPRING, EX. VALVE	E-9-10-14	TUBE A, AIR VENT	E-18-10-4	WASHER, PLAIN, 12MM	F-3-20-45
SPRING, FLUSH VALVE	E-6-10-8	TUBE B, AIR VENT	E-18-10-5	WASHER, PLAIN, 12MM	F-4-21
SPRING, LOCK ADJUSTER	F-8-7	TUBE B, BREATHER	E-1-26	WASHER, PLAIN, 12MM	F-5-20
SPRING, LOCK LEVER RETURN	F-8-10-18	TUBE C, BREATHER	E-1-27	WASHER, PLAIN, 12MM	F-5-1-22
SPRING, MOTOR	F-11-9	TUBE COMP. A, BREATHER	E-1-25	WASHER, PLAIN, 12MM	F-8-15
SPRING, NEUTRAL LOCK ARM	FOP-1-4-7	TUBE COMP. A, FUEL	F-8-20-1	WASHER, PLAIN, 12MM	F-10-63
SPRING, RELIEF VALVE	E-5-9	TUBE COMP. B, FUEL	E-18-1-8	WASHER, PLAIN, 12MM	F-10-64
SPRING, RELIEF VALVE	E-6-10-11	TUBE COMP. D, FUEL	E-18-1-9	WASHER, PLAIN, 14MM	F-3-20-44
SPRING, REMOTE CONTROL HANDLE	FOP-1-6-7	TUBE COMP. E, FUEL	E-18-1-10	WASHER, PLAIN, 4MM	FOP-1-6-56
SPRING, ROCKER ARM	E-9-10-9	TUBE COMP. G, FUEL	E-1-9	WASHER, PLAIN, 5MM	FOP-1-31
SPRING, SET	E-18-40	TUBE COMP., AIR VENT	E-18-10-6	WASHER, PLAIN, 5MM	FOP-1-33
SPRING, SHIFT	F-5-6	TUBE COMP., FUEL(C)	E-1-8	WASHER, PLAIN, 5MM	FOP-1-2-36
SPRING, SHIFT	F-5-1-6	TUBE KIT, SPEED SENSOR	F-10-2	WASHER, PLAIN, 5MM	FOP-1-2-38
SPRING, SHIFT CLICK	FOP-1-6-24	TUBE, 5X200	F-10-74	WASHER, PLAIN, 5MM	FOP-1-6-57
SPRING, SHIFT ROD	F-4-10	TUBE, 5X950	F-10-75	WASHER, PLAIN, 5MM	FOP-1-6-58
SPRING, SUPPORT	E-7-15	TUBE, CHECK VALVE	E-18-10-3	WASHER, PLAIN, 5MM	FOP-6-4
SPRING, VALVE(PINK)	E-9-10-13	TUBE, FLUSH VALVE	E-6-10-41	WASHER, PLAIN, 5MM	FOP-7-21
STAY, A.C. GENERATOR	E-19-16	TUBE, FUEL, 3.5X130	E-14-10-21	WASHER, PLAIN, 5MM	FOP-7-1-18
STAY, FUEL PIPE A	E-18-1-2	TUBE, FUEL, 3.5X40	E-14-10-20	WASHER, PLAIN, 6MM	E-15-24
STAY, FUEL PIPE B	E-18-1-3	TUBE, FUEL, 3.5X50	E-14-31	WASHER, PLAIN, 6MM	F-2-31
STAY, FUEL STRAINER	E-18-1-17	TUBE, FUEL, 3.5X540	E-14-10-22	WASHER, PLAIN, 6MM	F-2-33
STAY, PLATE	E-18-8	TUBE, FUEL, 3.5X55	E-18-10-23	WASHER, PLAIN, 6MM	F-2-34
STAY, PLATE	E-18-36	TUBE, FUEL, 3.5X590	E-14-10-23	WASHER, PLAIN, 6MM	F-8-14
STAY, POWER TILT SWITCH	F-3-20-6	TUBE, FUEL, 3.5X600	E-14-10-24	WASHER, PLAIN, 6MM	F-10-61
STAY, VACUUM TANK	E-18-44	TUBE, L. WATER RETURN	E-4-9	WASHER, PLAIN, 6MM	FOP-1-4-27
STAY, WATER SEPARATOR	E-18-1-7	TUBE, OIL	E-1-5	WASHER, PLAIN, 6MM	FOP-1-6-59
STOPPER SET, SLEEVE	E-21-8	TUBE, R. WATER RETURN	E-4-6	WASHER, PLAIN, 8MM	E-1-20
STOPPER SET, SLEEVE	E-21-8	TUBE, SPIRAL(12X14.6)	F-11-4	WASHER, PLAIN, 8MM	E-6-12
STOPPER, LOWER MOUNT	F-3-20-18	TUBE, VINYL, 3.5X6.5X350	E-18-1-33	WASHER, PLAIN, 8MM	F-7-10-19
STOPPER, TILT	F-10-29	TUBE, VINYL, 3.5X6.5X600	E-18-10-24	WASHER, PLAIN, 8MM	F-8-10-28
STRAINER ASSY., FUEL	E-18-1-11	TUBE, WATER	E-4-8	WASHER, PLAIN, 8MM	F-8-10-35
STRAINER COMP., OIL	E-5-7	TUBE, WATER CHECK	E-6-10-40	WASHER, PLAIN, 8MM	FOP-1-6-61
STRAINER, FUEL PUMP	E-18-10-8	TUBE, WATER IN	E-18-10-15	WASHER, PROPELLER	F-5-17
SUB HARNESS ASSY., POWER TRIM-TILT(A)	FOP-1-19	TUBE, WATER JOINT	F-3-20-51	WASHER, PROPELLER	F-5-17
SUB HARNESS ASSY., POWER TRIM-TILT(A)	FOP-1-2-20	TUBE, WATER OUTLET	E-18-10-16	WASHER, PROPELLER	F-5-1-17
SUB HARNESS ASSY., POWER TRIM-TILT(B)	FOP-1-2-21	TUBE, WATER RELIEF	E-4-7	WASHER, PROPELLER	F-5-1-17
SUB HARNESS ASSY., POWER TRIM-TILT(C)	FOP-1-4-16	TUBE, WATER(L)	F-4-7	WASHER, PROPELLER THRUST	F-5-15
SUSPENSION, COUPLER	F-7-2	TUBE, WATER(XL)	F-4-7	WASHER, PROPELLER THRUST	F-5-15
SUSPENSION, STRAINER	E-18-1-18	<V>		WASHER, PROPELLER THRUST	F-5-1-15
SUSPENSION, STRAINER	E-18-1-19	VALVE ASSY., AIR BYPASS	E-14-10-10	WASHER, SEALING(22MM)	E-3-8
SUSPENSION, STRAINER	E-18-10-9	VALVE ASSY., EAC	E-15-17	WASHER, SEALING(22MM)	E-3-10-3
SWITCH ASSY., COMBINATION	FOP-1-6-38	VALVE ASSY., SPOOL	E-3-18	WASHER, SEALING, 22MM	E-3-7
SWITCH ASSY., COMBINATION	FOP-1-7-33	VALVE COMP., MANUAL	F-11-25	WASHER, SEALING, 6MM	E-18-53
SWITCH ASSY., COMBINATION	FOP-7-9	VALVE COMP., RESERVOIR	F-11-26	WASHER, SPRING, 5MM	FOP-6-5
SWITCH ASSY., COMBINATION	FOP-7-1-7	VALVE SET, FLOAT	E-18-1	WASHER, SPRING, 5MM	FOP-7-22
SWITCH ASSY., EMERGENCY STOP	FOP-1-6-41	VALVE, CHECK	E-14-10-9	WASHER, SPRING, 5MM	FOP-7-1-19
SWITCH ASSY., EMERGENCY STOP	FOP-1-7-37	VALVE, CHECK	E-18-10-18	WASHER, THRUST	E-7-11
SWITCH ASSY., EMERGENCY STOP	FOP-7-10	VALVE, EX	E-9-10-11	WASHER, THRUST BEARING	F-5-16
SWITCH ASSY., EMERGENCY STOP	FOP-7-1-8	VALVE, FLASH	E-6-10-10	WASHER, THRUST BEARING	F-5-1-16
SWITCH ASSY., MAGNET	E-21-12	VALVE, IN	E-9-10-10	WASHER, THRUST, 14MM	F-2-29
SWITCH ASSY., MAGNET	E-21-12	VALVE, RELIEF	E-5-8	WASHER, THRUST, 34MM	F-10-56
SWITCH ASSY., NEUTRAL	F-2-18	VALVE, RELIEF	E-6-10-9	WASHER, THRUST, 48X74X3	F-5-1-21
SWITCH ASSY., OIL PRESSURE	E-3-24	<W>		WASHER, THRUST, 85X110X2	F-5-1-20
SWITCH ASSY., OIL PRESSURE	E-3-25	WASHER	F-2-32	WASHER, UPPER MOUNTING STOPPER	F-10-57
SWITCH ASSY., POWER TILT	F-3-20-5	WASHER B, THRUST, 14MM	F-2-30	WASHER, UPPER MOUNTING STOPPER	F-10-57
SWITCH ASSY., POWER TRIM-TILT	FOP-1-6-39	WASHER KIT, THRUST(250)	E-7-16	WASHER, UPPER MOUNTING STOPPER	F-10-57
SWITCH ASSY., POWER TRIM-TILT	FOP-1-7-34	WASHER(3)	FOP-1-7-58	WASHER, WAVE	FOP-1-7-63
SWITCH ASSY., POWER TRIM-TILT (A)	FOP-1-20	WASHER(4)	FOP-1-7-59	WASHER, WAVE, 10MM	F-8-10-34
SWITCH ASSY., POWER TRIM-TILT (A)	FOP-1-2-22	WASHER(5)	FOP-1-7-60	WASHER, WAVE, 12MM	F-10-54
SWITCH ASSY., POWER TRIM-TILT (B)	FOP-1-2-23	WASHER(7)(LOOSE PARTS)	FOP-1-7-62	WASHER, WAVE, 26MM	F-10-55
SWITCH ASSY., POWER TRIM-TILT (C)	FOP-1-4-17	WASHER, 10MM	F-10-62	WASHER, WAVE, 40MM	F-10-53
SWITCH KIT, LIGHT	FOP-6-1	WASHER, 25MM	F-10-59	WASHER, WAVE, 8MM	F-8-10-33
<T>		WASHER, 28MM	FOP-1-6-62	WHEEL, ACCELERATOR	FOP-1-6-20
TAB, TRIM	F-3-8	WASHER, 30MM	F-3-20-43	WHEEL, CONTROL	FOP-1-6-13
TACHOMETER HOUR METER	FOP-3-2	WASHER, 6MM	FOP-1-6-60	WIRE, LEAD(1.5X116MM)	F-10-9
TACHOMETER HOUR METER	FOP-3-2	WASHER, 7/8INCH	F-10-58	WIRE, LEAD(1.5X116MM)	F-11-11
TANK COMP., VACUUM	E-18-43	WASHER, 8MM	FOP-1-7-61	WRENCH, BOX(10MM)	F-13-14
TANK, OIL	F-11-29	WASHER, AIR CLEANER COVER		WRENCH, EYE, 19MM	F-13-12
TENSIONER COMP., TIMING BELT	E-13-7	SETTING	F-2-1	WRENCH, HEX, 6MM	F-13-7
TERMINAL, CABLE	FOP-1-16	WASHER, CONICAL SPRING(5)	E-14-10-11	WRENCH, PLUG	F-13-6
TERMINAL, CABLE	FOP-1-2-17	WASHER, DRAIN PLUG, 12MM	E-6-13	<Y>	
TERMINAL, CABLE	FOP-1-4-12	WASHER, LOCK, 5MM	FOP-1-30	YOKE ASSY.	F-11-8
TERMINAL, CABLE(LOOSE PARTS)	FOP-1-7-25	WASHER, LOCK, 5MM	FOP-1-2-35	YOKE COMP.	E-21-5
THERMOSTAT ASSY.	E-4-10	WASHER, LOCK, 5MM	FOP-1-4-26		
THROTTLE BODY ASSY.	E-15-3	WASHER, LOCK, 6MM	FOP-1-32		
TIE, CABLE	FOP-10-2	WASHER, LOCK, 6MM	FOP-1-2-37		
TIE, CABLE(NATURAL)(2.4X92)	FOP-1-6-37	WASHER, PIVOT	F-2-4		
TIE, CABLE(NATURAL)(2.4X92)	FOP-13-4	WASHER, PLAIN	E-18-24		
T-JOINT	E-1-10	WASHER, PLAIN	E-18-25		
T-JOINT	E-18-10-17	WASHER, PLAIN, 10MM	E-6-20-8		
TRIM METER ASSY	FOP-3-1	WASHER, PLAIN, 10MM	F-3-23		
		WASHER, PLAIN, 10MM	F-3-20-46		
		WASHER, PLAIN, 10MM	F-8-10-32		
		WASHER, PLAIN, 10MM	F-10-60		

INDEX (Parts Number)

332-70201-0	F-6-8	HCO-94301-06100	E-13-30	HMM8-90502-610	F-8-10-32	HPT0-90005-003	E-9-11
3C7-70217-0	F-6-5	HCO-94301-06100	E-15-28	HMR5-16966-000	F-8-20-5	HPT0-90206-004	E-9-10-20
3C7-70220-1	F-6-2	HCO-94301-08140	E-3-10-18	HMT2-17193-000	E-1-10	HPT0-90705-000	E-9-15
3C7-70224-1	F-6-3	HCO-94301-10120	E-14-30	HMT8-18334-770	FOP-6-2	HPT2-91005-N01	F-5-23
3FF-70200-4	F-6-1	HCO-94302-06100	E-9-18	HMT8-18334-770	FOP-7-2	HPT2-91005-N01	F-5-1-24
3GF-70211-1	F-6-4	HCO-94302-10160	E-5-20	HMT8-18334-770	FOP-7-1-2	HPW5-90701-000	E-5-15
3GF-70240-1	F-6-7	HCO-94302-10160	E-6-20-10	HP01-91212-003	E-5-17	HPW5-90701-000	E-6-20-9
3GF-70241-1	F-6-6	HCO-94303-05080	E-3-54	HP08-12342-004	E-1-4	HPY3-17249-000	E-15-7
3PU-72537-0	FOP-3-3	HCO-94305-30203	F-10-73	HP0A-91303-A02	E-15-25	HPY3-31215-004	E-21-4
3PU-72571-0	FOP-3-1	HCO-94510-15000	F-5-31	HP0X-91321-003	E-3-49	HPY3-31218-004	E-21-6
3PU-72637-0	FOP-3-2	HCO-94510-15000	F-5-1-34	HP13-31141-003	E-19-6	HPZ1-12210-004	E-9-4
3PV-72571-0	FOP-3-1	HCO-94520-47000	F-4-37	HP13-31147-003	E-19-10	HPZ1-12211-004	E-9-6
3PV-72637-0	FOP-3-2	HCO-94540-03029	FOP-1-6-78	HP13-31148-003	E-19-12	HR70-15280-A00	E-3-13
H121-51640-730	F-8-10-11	HCO-94540-04029	F-2-42	HP5A-13115-000	E-7-4	HRCA-14632-A00	E-9-10-8
H196-47117-000	F-8-10-10	HCO-94540-04029	FOP-1-6-79	HP5A-31201-005	E-21-2	HRCA-17055-A01	E-14-12
H341-38403-672	FOP-1-6-45	HCO-94540-06029	F-8-10-39	HP5A-31243-005	E-21-14	HRCA-17065-A01	E-14-14
H341-38403-672	FOP-1-7-40	HCO-94540-06029	FOP-1-36	HP5G-16614-003	E-14-4	HRCA-90014-A01	E-3-32
H341-38403-672	FOP-7-15	HCO-94540-06029	FOP-1-2-41	HP8A-11812-A00	E-13-10-1	HRCA-90704-A00	E-13-28
H341-38403-672	FOP-7-1-12	HCO-94540-06029	FOP-1-4-28	HP8A-13204-A01	E-7-6	HRDV-14765-J00	E-9-10-15
H355-89217-000	F-13-14	HCO-94540-07029	FOP-1-6-80	HP8A-14400-A01	E-13-6	HRGM-14781-A01	E-9-10-17
H371-89221-000	F-13-7	HCO-94540-10019	F-4-34	HP8A-14551-A01	E-13-13	HRJA-14711-000	E-9-10-10
H371-90009-015	E-6-20-2	HCO-94540-12029	F-2-43	HP8A-14620-A01	E-9-10-4	HRJA-14721-E00	E-9-10-11
H560-90715-A00	E-3-41	HCO-94540-15029	F-11-51	HP8A-14626-A00	E-9-10-5	HRJA-15290-000	E-3-14
H663-38562-920	F-10-8	HCO-95001-35040-40	E-14-10-20	HP8A-14627-A00	E-9-10-6	HRJA-90017-003	E-13-22
H723-90472-000	F-4-21	HCO-95001-35050-40	E-14-31	HP8A-14631-A00	E-9-10-7	HRKG-13210-000	E-7-7
H759-16911-003	E-18-10-8	HCO-95001-35055-40	E-18-10-23	HP8A-14645-A01	E-9-10-9	HRKG-13310-000	E-7-9
H763-90681-A01	F-7-10-21	HCO-95001-35130-40	E-14-10-21	HP8A-15115-A01	E-3-9	HRKG-14761-003	E-9-10-13
H763-90681-A01	F-10-67	HCO-95001-35540-40	E-14-10-22	HP8A-15140-A00	E-3-10	HRKG-91213-003	E-9-16
H800-91303-000	E-6-10-36	HCO-95001-35590-60	E-14-10-23	HP8A-15142-A00	E-3-11	HRNA-30530-A01	E-3-20
H805-91301-000	E-3-10-17	HCO-95001-35600-40	E-14-10-24	HP8A-15150-A00	E-3-12	HRNA-37830-A01	E-14-10-12
H881-90110-000	F-10-42	HCO-95003-05035-31	E-18-1-33	HP8A-90003-A00	E-9-10-18	HRTA-15400-004	E-3-10-4
H921-15611-000	E-3-10-5	HCO-95003-05060-31	E-18-10-21	HP8A-90004-A00	E-9-10-19	HRYE-13211-A01	E-7-8
H921-17936-000	F-2-4	HCO-95005-50200-30	F-10-74	HP8A-90017-A01	E-13-10-8	HRYE-13212-A01	E-7-8
H921-90302-000	F-3-20-41	HCO-95005-50950-30	F-10-75	HP8A-90031-A01	E-13-25	HRYE-13213-A01	E-7-8
H921-90302-000	FOP-1-6-54	HCO-95011-63000	F-3-20-55	HP8A-90701-A00	E-9-14	HRYE-13214-A01	E-7-8
H921-90302-000	FOP-1-7-55	HCO-95551-20000	F-8-19	HP8A-91301-A00	E-9-17	HRYE-13215-A01	E-7-8
H921-90302-000	FOP-7-19	HCO-95701-06014-09	E-5-21	HP8A-91308-A01	E-3-45	HS0A-91541-003	E-3-50
H921-90302-000	FOP-7-1-16	HCO-95701-06018-09	E-5-22	HP8A-91309-A01	E-3-47	HS0A-91541-003	E-13-10-11
H921-90504-010	F-8-14	HCO-95701-08030-09	E-5-23	HP8D-36165-J00	E-14-10-11	HS0A-91541-003	F-2-41
H921-90504-010	FOP-1-6-59	HCO-95701-10070-09	E-6-20-11	HP8E-14762-A01	E-9-10-14	HS0A-91541-003	F-7-5
H921-90511-000	F-10-60	HCO-95701-12120-09	E-6-20-12	HP8E-17105-A01	E-6-14-15	HS0A-91541-003	F-7-10-24
H921-90512-010	FOP-1-6-60	HCO-96211-07000	F-5-32	HP8F-14820-A01	E-9-10	HS0A-91541-003	F-8-10-37
H921-90518-000	F-8-10-35	HCO-96211-07000	F-5-1-35	HPC6-15233-000	E-5-10	HS0X-46392-A01	F-2-21
H921-90518-000	FOP-1-6-61	HCO-96211-12000	F-5-33	HPC6-91324-000	E-5-18	HS0A-90683-003	E-18-1-31
H921-90602-000	E-18-1-27	HCO-96211-12000	F-5-1-36	HPD1-31138-004	E-19-5	HS0A-90683-003	E-20-10-10
H921-90602-000	F-10-65	HCO-96220-50080	E-5-24	HPD1-31142-004	E-19-7	HS0A-90683-003	F-3-20-49
H952-32901-770	FOP-1-6-37	HCO-98078-5617C	E-20-3	HPD1-31145-004	E-19-8	HSB0-90602-003	F-11-37
H952-32901-770	FOP-13-4	HCO-98200-41000	F-7-20-9	HPD1-90231-014	E-19-26	HSB2-90620-003	F-7-10-20
H958-90428-000	F-2-30	HCO-98200-41500	F-7-20-10	HPD6-90430-003	E-18-53	HSB2-90620-003	F-7-10-20
HCO-92101-05016-4J	FOP-1-6-69	HCO-98200-43000	F-7-20-11	HPPE-15231-000	E-5-8	HSB2-90650-003	E-14-26
HCO-92101-06055-4J	F-3-26	HCO-99003-30000	F-13-15	HPEA-13111-000	E-7-3	HSB6-91475-000	FOP-1-6-66
HCO-93500-05010-4J	FOP-1-6-70	HCO-99003-50000	F-13-16	HPF0-91302-003	F-2-40	HSC2-90649-003	FOP-7-20
HCO-93500-05065-4J	E-3-51	HCO-99006-19000	F-13-12	HPG4-91033-013	F-5-1-25	HSC2-90649-003	FOP-7-1-17
HCO-93500-05020-4J	E-3-52	HCO-99008-02000	F-13-13	HPG6-15232-000	E-5-9	HSD2-90705-931	F-2-35
HCO-93500-05065-4J	FOP-1-34	HGCF-80106-670	F-8-20-3	HPG7-16741-005	E-14-7	HSD4-91356-952	E-4-25
HCO-93500-05016-4J	FOP-1-2-39	HGHB-16163-600	E-18-1-1	HPGK-37835-A01	E-14-10-13	HSD9-54316-013	E-1-15
HCO-93500-06018-4J	E-4-26	HGHB-16163-610	E-6-10-1	HPH1-90015-013	E-3-10-7	HSDA-39794-004	F-7-20-5
HCO-93500-06025-4J	F-3-20-40	HHA0-90402-000	F-2-29	HPH7-90715-000	E-3-41	HSE0-53740-953	E-1-14
HCO-93600-06016-0A	E-5-19	HHE0-50310-003	E-1-13	HPJ7-12204-305	E-9-2	HSF4-89216-000	F-13-6
HCO-93901-250J0	FOP-1-6-71	HHW1-90207-671	E-6-10-31	HPJ7-12205-305	E-9-3	HSJ6-78419-003	E-14-18
HCO-93901-251J0	FOP-1-6-72	HHW1-90215-671	F-4-18	HPK1-91308-003	E-3-46	HSK7-91566-003	E-1-28
HCO-93901-252J0	FOP-1-6-73	HKE8-17251-690	F-8-1	HLPC-91301-000	E-14-28	HSLO-91592-A51	E-18-10-22
HCO-93903-262J0	FOP-1-6-74	HKG4-90659-000	E-18-1-30	HPM3-14775-000	E-9-10-16	HSTK-91540-003	FOP-10-3
HCO-93905-255J0	FOP-1-6-75	HKM3-32161-003	F-10-6	HPM4-36145-004	E-14-10-9	HVM0-16965-771	E-18-10-10
HCO-93911-141J0	F-8-17	HKM3-32161-003	F-10-76	HPNA-91214-014	E-3-43	HZA0-90684-601	F-8-10-36
HCO-94001-05490-05	FOP-1-35	HKN5-17224-670	F-2-1	HPNA-91302-003	E-14-29	HZB7-90691-003	E-1-23
HCO-94001-05490-05	FOP-1-2-40	HKT7-91305-003	E-1-24	HPNA-91307-003	E-3-44	HZB7-90691-003	E-18-54
HCO-94001-06080-05	E-19-27	HKV6-90651-003	F-7-10-20	HPNA-91307-003	E-4-24	HZC0-63515-700	F-8-10-24
HCO-94001-06490-05	FOP-1-6-76	HKY7-17450-740	E-18-10-11	HPP4-90009-E01	E-18-46	HZE2-90601-000	E-6-13
HCO-94001-12490-05	F-10-72	HMB1-90655-921	E-18-10-21	HPR3-91319-003	E-3-48	HZV0-41122-000	E-13-19
HCO-94002-05490-05	FOP-1-6-77	HMG9-17201-000	E-14-10-7	HPR7-31105-A01	E-19-1	HZV0-90604-000	E-1-22
HCO-94002-06490-05	F-8-18	HMG9-35701-950	F-11-3	HPR7-36361-A01	E-18-43	HZV0-90604-000	E-18-1-28
HCO-94103-05400	FOP-6-4	HMG9-35701-950	FOP-1-6-40	HPT0-14744-004	E-9-10-12	HZV0-90604-000	E-18-10-20
HCO-94103-05400	FOP-7-21	HMJ0-91301-003	E-14-27	HPT0-31111-003	E-19-2	HZV1-24210-010	F-10-4
HCO-94103-05400	FOP-7-1-18	HMJ0-91301-003	E-18-55	HPT0-31114-013	E-19-3	HZV1-87538-C23	F-12-8
HCO-94111-05400	FOP-6-5	HMJ0-91308-003	F-4-29	HPT0-31118-003	E-19-4	HZV4-12155-A00	E-3-4
HCO-94111-05400	FOP-7-22	HMJ0-91308-003	FOP-12-7	HPT0-31146-003	E-19-9	HZV4-17704-010	F-8-20-4
HCO-94111-05400	FOP-7-1-19	HML0-90101-720	F-8-10-28	HPT0-31147-003	E-19-11	HZV4-24221-010	F-10-5
HCO-94301-06100	E-3-53	HMM4-90105-000	FOP-1-6-51	HPT0-31148-003	E-19-13	HZV4-36182-651	FOP-1-6-42

HZV4-36182-651.	FOP-1-7-38	HZV5-90009-000.	E-6-8	HZW1-90106-004.	E-21-21	HZW5-24831-U01.	FOP-1-2-17
HZV4-36182-651.	FOP-7-11	HZV5-90009-000.	F-8-10-26	HZW1-90107-004.	E-21-22	HZW5-24831-U01.	FOP-1-4-12
HZV4-36182-651.	FOP-7-1-9	HZV5-90012-013.	E-13-21	HZW1-90108-000.	F-10-41	HZW5-24832-U01.	FOP-1-17
HZV4-36187-652.	FOP-1-6-43	HZV5-90081-010.	E-3-39	HZW1-90113-702.	F-11-31	HZW5-24832-U01.	FOP-1-2-18
HZV4-36187-652.	FOP-7-12	HZV5-90081-010.	E-3-10-12	HZW1-90114-702.	F-11-32	HZW5-24832-U01.	FOP-1-4-13
HZV4-36187-652.	FOP-7-1-10	HZV5-90081-010.	E-5-25	HZW1-90115-702.	F-11-33	HZW5-24834-U01.	FOP-1-18
HZV4-90127-000.	E-6-10	HZV5-90110-000.	F-3-20-34	HZW1-90116-702.	F-11-34	HZW5-24834-U21.	FOP-1-2-19
HZV4-90127-000.	F-2-27	HZV5-90119-000.	F-10-44	HZW1-90203-000.	F-7-10-17	HZW5-32168-003.	E-18-42
HZV4-90302-000.	F-3-19	HZV5-90119-000.	F-10-77	HZW1-90301-800.	F-5-14	HZW5-35370-U02.	FOP-1-20
HZV4-90304-000.	FOP-1-6-55	HZV5-90119-000.	F-11-35	HZW1-90301-800.	F-5-1-14	HZW5-35370-U02.	FOP-1-2-22
HZV4-90502-000.	FOP-1-31	HZV5-90125-000.	FOP-1-6-53	HZW1-90304-013.	F-10-50	HZW5-35370-U12.	FOP-1-2-23
HZV4-90502-000.	FOP-1-2-36	HZV5-90127-003.	F-10-45	HZW1-90308-003.	F-3-21	HZW5-35665-003.	E-15-16
HZV4-90502-000.	FOP-1-6-58	HZV5-90127-003.	F-11-36	HZW1-90401-000.	E-6-12	HZW5-90002-013.	E-5-14
HZV4-90506-000.	F-2-31	HZV5-90131-000.	E-6-11	HZW1-90652-702.	F-11-38	HZW5-90011-010.	E-19-22
HZV4-90512-000.	F-2-34	HZV5-90302-003.	F-2-28	HZW1-90758-800.	F-5-22	HZW5-90018-000.	E-20-10-9
HZV4-90512-000.	F-10-61	HZV5-90304-013.	F-10-49	HZW1-90758-800.	F-5-1-23	HZW5-90018-000.	F-7-20-7
HZV4-90514-000.	F-10-62	HZV5-90306-003.	F-3-20	HZW1-90758-800.	FOP-12-2	HZW5-90021-U00.	FOP-5-2
HZV4-90603-000.	E-6-10-32	HZV5-90307-003.	F-10-52	HZW1-91207-013.	F-11-40	HZW5-90023-000.	F-2-24
HZV4-90605-000.	E-6-10-33	HZV5-90501-000.	F-10-53	HZW1-91352-702.	F-11-43	HZW5-90101-U00.	FOP-1-22
HZV4-90605-000.	E-18-1-29	HZV5-90502-000.	F-10-55	HZW1-91353-703.	F-11-44	HZW5-90101-U00.	FOP-1-2-25
HZV4-90605-000.	F-3-20-47	HZV5-90504-000.	F-10-56	HZW1-91354-701.	F-11-45	HZW5-90101-U00.	FOP-1-4-20
HZV5-12155-000.	E-4-1	HZV5-90552-000.	F-10-63	HZW1-91355-701.	F-11-46	HZW5-90102-U00.	FOP-1-23
HZV5-12214-000.	E-3-8	HZV5-90557-000.	FOP-1-6-62	HZW1-91357-701.	F-11-47	HZW5-90102-U00.	FOP-1-2-26
HZV5-12214-000.	E-3-10-3	HZV5-90559-000.	E-6-20-7	HZW1-91358-701.	F-11-48	HZW5-90103-U01.	FOP-1-24
HZV5-24811-010.	FOP-1-6-2	HZV5-90559-000.	F-3-22	HZW1-91361-701.	F-11-49	HZW5-90103-U01.	FOP-1-2-27
HZV5-24812-000.	FOP-1-6-3	HZV5-90559-000.	F-3-20-45	HZW1-91554-000.	E-18-56	HZW5-90104-U00.	FOP-1-25
HZV5-24813-000.	FOP-1-6-4	HZV5-90559-000.	F-5-20	HZW1-91554-000.	F-8-10-38	HZW5-90104-U00.	FOP-1-2-28
HZV5-24814-010.	FOP-1-6-5	HZV5-90559-000.	F-5-1-22	HZW1-91557-701.	F-11-50	HZW5-90105-U01.	FOP-1-26
HZV5-24815-010.	FOP-1-6-6	HZV5-90559-000.	F-10-64	HZW2-90003-000.	E-20-10-7	HZW5-90105-U01.	FOP-1-2-29
HZV5-24816-000.	FOP-1-6-7	HZV5-90563-000.	E-6-20-8	HZW2-90003-000.	F-7-10-12	HZW5-90106-U00.	FOP-1-27
HZV5-24817-000.	FOP-1-6-8	HZV5-90563-000.	F-3-23	HZW4-90108-000.	FOP-1-6-52	HZW5-90106-U00.	FOP-1-2-30
HZV5-24818-003.	FOP-1-6-9	HZV5-90563-000.	F-3-20-46	HZW4-90126-000.	E-1-19	HZW5-90107-U00.	FOP-1-28
HZV5-24820-010.	FOP-1-6-10	HZV5-90651-000.	F-10-66	HZW4-90147-000.	E-3-10-14	HZW5-90107-U00.	FOP-1-2-31
HZV5-24830-010.	FOP-1-6-11	HZV5-90751-000.	FOP-1-6-63	HZW4-90151-000.	E-3-10-15	HZW5-90108-U00.	FOP-1-2-32
HZV5-24836-000.	FOP-1-6-12	HZV5-90756-000.	F-3-24	HZW4-90155-000.	E-4-19	HZW5-90109-000.	FOP-6-3
HZV5-24841-000.	FOP-1-6-13	HZV5-90756-000.	F-3-24	HZW4-90156-000.	E-3-40	HZW5-90109-000.	FOP-7-18
HZV5-24845-000.	FOP-1-6-14	HZV5-90756-000.	F-3-20-50	HZW4-90156-000.	E-14-10-18	HZW5-90109-000.	FOP-7-1-15
HZV5-24850-000.	FOP-1-6-15	HZV5-90756-000.	F-4-24	HZW4-90306-003.	F-10-51	HZW5-90203-010.	E-19-25
HZV5-24854-000.	FOP-1-6-16	HZV5-90772-000.	FOP-1-6-64	HZW4-90401-000.	FOP-1-6-56	HZW5-90301-U00.	FOP-1-29
HZV5-24855-000.	FOP-1-6-17	HZV5-91151-000.	FOP-1-6-65	HZW4-90402-000.	FOP-1-6-57	HZW5-90301-U00.	FOP-1-2-33
HZV5-24860-000.	FOP-1-6-18	HZV5-91203-821.	F-11-39	HZW4-91301-003.	F-3-25	HZW5-90302-003.	F-10-48
HZV5-24865-000.	FOP-1-6-19	HZV5-91256-003.	F-10-69	HZW4-91301-003.	FOP-12-6	HZW5-90302-U21.	FOP-1-2-34
HZV5-24875-000.	FOP-1-6-20	HZV5-91302-821.	F-11-41	HZW5-06241-U00.	FOP-1-2	HZW5-90501-U00.	FOP-1-30
HZV5-24876-000.	FOP-1-6-21	HZV5-91316-821.	F-11-42	HZW5-06241-U10.	FOP-1-2-2	HZW5-90501-U00.	FOP-1-2-35
HZV5-24878-000.	FOP-1-6-22	HZV5-91352-000.	F-10-70	HZW5-06352-U01.	FOP-6-1	HZW5-90501-U00.	FOP-1-4-26
HZV5-24881-000.	FOP-1-6-23	HZV5-91553-010.	E-15-26	HZW5-06900-U00.	FOP-5-1	HZW5-90502-U00.	FOP-1-32
HZV5-24883-000.	FOP-1-6-24	HZV5-91553-010.	E-20-5	HZW5-16081-010.	E-18-20	HZW5-90502-U00.	FOP-1-2-37
HZV5-24884-000.	FOP-1-6-25	HZV5-91553-010.	E-20-10-11	HZW5-16086-000.	E-18-23	HZW5-90503-U00.	FOP-1-33
HZV5-24885-000.	FOP-1-6-26	HZV5-91553-010.	F-7-10-25	HZW5-16087-000.	E-18-24	HZW5-90503-U00.	FOP-1-38
HZV5-24887-000.	FOP-1-6-27	HZV5-91563-000.	F-3-20-53	HZW5-16715-023.	E-18-29	HZW5-90509-711.	F-5-16
HZV5-24891-000.	FOP-1-6-28	HZV5-91567-000.	FOP-1-6-67	HZW5-16733-000.	E-18-34	HZW5-90509-711.	F-5-1-16
HZV5-24892-000.	FOP-1-6-29	HZV5-91570-000.	FOP-1-6-68	HZW5-16915-000.	E-18-10-9	HZW5-90511-U00.	FOP-5-3
HZV5-24894-000.	FOP-1-6-30	HZV7-90508-000.	F-2-32	HZW5-19291-000.	E-6-10-9	HZW5-90512-U00.	FOP-5-4
HZV5-24895-000.	FOP-1-6-31	HZV7-90951-010.	F-10-68	HZW5-19292-000.	E-6-10-11	HZW5-90601-030.	E-18-10-19
HZV5-24897-000.	FOP-1-6-32	HZW1-06411-020.	F-10-1	HZW5-19297-000.	E-6-10-15	HZW5-91201-003.	E-5-16
HZV5-24898-000.	FOP-1-6-33	HZW1-15631-000.	E-3-10-6	HZW5-24810-U01.	FOP-1-3	HZW5-91202-003.	E-6-10-35
HZV5-32823-003.	FOP-1-6-35	HZW1-19286-B00.	F-3-1	HZW5-24810-U01.	FOP-1-2-3	HZW5-91251-003.	F-2-38
HZV5-32823-003.	FOP-1-7-31	HZW1-24210-010.	F-2-5	HZW5-24810-U11.	FOP-1-2-4	HZW7-24810-U01.	FOP-1-4-2
HZV5-32823-003.	FOP-7-7	HZW1-24327-000.	F-2-7	HZW5-24811-U01.	FOP-1-4	HZW7-24811-U01.	FOP-1-4-3
HZV5-32823-003.	FOP-7-1-5	HZW1-24343-B02.	F-4-12	HZW5-24811-U01.	FOP-1-2-5	HZW7-24812-U01.	FOP-1-4-4
HZV5-32824-003.	FOP-1-6-36	HZW1-24629-000.	F-2-17	HZW5-24812-U01.	FOP-1-5	HZW7-24813-U01.	FOP-1-4-5
HZV5-32824-003.	FOP-1-7-32	HZW1-31226-004.	E-21-7	HZW5-24812-U01.	FOP-1-2-6	HZW7-24814-U01.	FOP-1-4-6
HZV5-32824-003.	FOP-7-8	HZW1-31229-004.	E-21-8	HZW5-24813-U01.	FOP-1-6	HZW7-24815-U01.	FOP-1-4-7
HZV5-32824-003.	FOP-7-1-6	HZW1-31231-004.	E-21-9	HZW5-24813-U01.	FOP-1-2-7	HZW7-24817-U01.	FOP-1-4-9
HZV5-35370-823.	FOP-1-6-39	HZW1-36104-003.	F-11-4	HZW5-24813-U21.	FOP-1-2-8	HZW7-24832-U01.	FOP-1-4-14
HZV5-36136-821.	F-11-9	HZW1-38551-000.	F-7-10-10	HZW5-24814-U01.	FOP-1-7	HZW7-24833-U01.	FOP-1-4-15
HZV5-36180-033.	FOP-1-6-41	HZW1-40107-700.	F-11-10	HZW5-24814-U01.	FOP-1-2-9	HZW7-32530-U00.	FOP-1-19
HZV5-36180-033.	FOP-1-7-37	HZW1-40209-000.	F-3-20-11	HZW5-24815-U01.	FOP-1-8	HZW7-32530-U00.	FOP-1-2-20
HZV5-36180-033.	FOP-7-10	HZW1-41102-B00.	F-3-4	HZW5-24816-U01.	FOP-1-9	HZW7-32530-U10.	FOP-1-2-21
HZV5-36180-033.	FOP-7-1-8	HZW1-41109-B00.	F-3-9	HZW5-24816-U01.	FOP-1-2-10	HZW7-32530-U20.	FOP-1-4-16
HZV5-38410-003.	FOP-1-6-46	HZW1-56110-701.	F-11-15	HZW5-24816-U01.	FOP-1-8	HZW7-35370-U02.	FOP-1-4-17
HZV5-38410-003.	FOP-1-7-41	HZW1-56113-701.	F-11-16	HZW5-24817-U01.	FOP-1-10	HZW7-87703-U00.	FOP-1-4-19
HZV5-38410-003.	FOP-7-16	HZW1-56116-701.	F-11-19	HZW5-24817-U01.	FOP-1-2-11	HZW7-90101-U01.	FOP-1-4-21
HZV5-38410-003.	FOP-7-1-13	HZW1-56130-702.	F-11-24	HZW5-24818-U01.	FOP-1-11	HZW7-90102-U01.	FOP-1-4-22
HZV5-40102-000.	E-15-18	HZW1-56180-701.	F-11-26	HZW5-24818-U01.	FOP-1-2-12	HZW7-90103-U01.	FOP-1-4-23
HZV5-40107-000.	F-3-20-7	HZW1-56539-000.	F-10-33	HZW5-24819-U01.	FOP-1-12	HZW7-90104-U01.	FOP-1-4-24
HZV5-41171-000.	F-10-10	HZW1-56539-000.	F-10-33	HZW5-24819-U01.	FOP-1-2-13	HZW7-90301-U01.	FOP-1-4-25
HZV5-41172-000.	F-10-11	HZW1-56851-703.	F-11-29	HZW5-24825-U01.	FOP-1-14	HZW7-90502-U00.	FOP-1-4-27
HZV5-50214-003.	F-11-12	HZW1-56860-701.	F-11-30	HZW5-24825-U01.	FOP-1-2-15	HZW9-19279-000.	E-6-10-8
HZV5-56117-821.	F-11-20	HZW1-90013-000.	E-15-19	HZW5-24826-U01.	FOP-1-15	HZW9-19291-000.	E-6-10-10
HZV5-56118-820.	F-11-21	HZW1-90013-000.	F-7-10-13	HZW5-24826-U01.	FOP-1-2-16	HZW9-19297-000.	E-6-10-16
HZV5-56513-000.	F-11-27	HZW1-90014-000.	E-18-47	HZW5-24826-U01.	FOP-1-4-10	HZW9-32114-730.	E-1-11
HZV5-82873-003.	F-3-20-30	HZW1-90102-000.	F-10-36	HZW5-24831-U01.	FOP-1-16	HZW9-32114-730.	E-3-21

HZW9-35490-003	...	E-3-24	HZX2-19511-000	...	E-13-16	HZX2-90101-C00	...	F-2-25	HZY3-14550-003	...	E-13-12
HZW9-87702-800	...	FOP-1-6-49	HZX2-19540-010	...	E-15-29	HZX2-90102-C00	...	F-3-20-31	HZY3-14553-003	...	E-13-14
HZW9-90005-000	...	F-10-34	HZX2-24101-C00	...	F-5-1	HZX2-90105-C00	...	F-4-17	HZY3-14555-003	...	E-13-15
HZW9-90008-000	...	FOP-1-6-50	HZX2-24101-C00	...	F-5-1-1	HZX2-90107-C00	...	F-3-13	HZY3-15100-000ZA	...	E-5-1
HZW9-90009-000	...	F-10-35	HZX2-30280-003	...	F-11-1	HZX2-90129-000	...	F-10-46	HZY3-15112-013	...	E-5-2
HZW9-90011-000	...	E-1-16	HZX2-30416-000	...	E-20-10-1	HZX2-90301-C00	...	F-4-19	HZY3-15113-000	...	E-5-3
HZW9-90011-000	...	E-13-20	HZX2-30520-003	...	E-20-2	HZX2-90303-C00	...	F-4-20	HZY3-15121-000	...	E-5-4
HZW9-90011-000	...	F-2-22	HZX2-31106-003	...	F-11-2	HZX2-90502-003	...	F-8-10-33	HZY3-15131-405	...	E-5-5
HZW9-90013-000	...	F-7-3	HZX2-31110-000ZA	...	E-5-11	HZX2-90504-C00	...	F-10-57	HZY3-15132-405	...	E-5-6
HZW9-90013-000	...	F-7-10-14	HZX2-31916-003	...	E-20-3	HZX2-90506-C00	...	F-5-15	HZY3-15220-020	...	E-5-7
HZW9-90014-000	...	E-18-1-25	HZX2-32100-010	...	F-7-1	HZX2-90506-C00	...	F-5-1-15	HZY3-15425-010	...	E-1-5
HZW9-90014-000	...	E-20-10-8	HZX2-32166-003	...	E-18-41	HZX2-90512-C00	...	F-5-17	HZY3-15656-000	...	E-3-16
HZW9-90014-000	...	F-7-10-15	HZX2-32370-004	...	F-7-20-1	HZX2-90512-C00	...	F-5-1-17	HZY3-15657-000	...	E-3-17
HZW9-90016-000	...	E-14-19	HZX2-32410-000	...	F-7-10-3	HZX2-90518-C00	...	F-4-22	HZY3-15810-003ZA	...	E-3-18
HZW9-90016-000	...	E-18-48	HZX2-32414-300	...	F-7-10-5	HZX2-90519-C00	...	F-4-22	HZY3-15825-003	...	E-3-19
HZW9-90019-000	...	E-1-17	HZX2-32415-000	...	F-7-10-7	HZX2-90520-C00	...	F-4-22	HZY3-16011-A01	...	E-18-1
HZW9-90019-000	...	E-3-34	HZX2-32435-000	...	F-7-10-8	HZX2-90521-C00	...	F-4-22	HZY3-16013-000	...	E-18-2
HZW9-90019-000	...	E-4-16	HZX2-34750-023	...	E-20-10-4	HZX2-90528-C00	...	F-5-18	HZY3-16015-000	...	E-18-3
HZW9-90019-000	...	E-14-20	HZX2-34750-043	...	E-20-10-4	HZX2-90528-C00	...	F-5-1-18	HZY3-16016-003	...	E-15-1
HZW9-90101-003	...	F-3-10	HZX2-35470-013	...	F-2-18	HZX2-90528-E00	...	F-5-1-19	HZY3-16024-000	...	E-18-5
HZW9-90102-000	...	F-2-26	HZX2-36120-013	...	F-11-5	HZX2-90529-C00	...	F-5-18	HZY3-16026-000	...	E-18-6
HZW9-90102-000	...	F-8-10-29	HZX2-36122-003	...	F-11-6	HZX2-90529-C00	...	F-5-1-18	HZY3-16031-010	...	E-18-8
HZW9-90103-010	...	F-10-37	HZX2-36129-003	...	F-11-8	HZX2-90529-E00	...	F-5-1-19	HZY3-16036-003	...	E-18-9
HZW9-90105-000	...	F-8-11	HZX2-38228-003	...	F-7-20-3	HZX2-90530-C00	...	F-5-18	HZY3-16041-000	...	E-18-10
HZW9-90105-000	...	F-8-10-30	HZX2-38550-003	...	F-7-10-9	HZX2-90530-C00	...	F-5-1-18	HZY3-16042-000	...	E-18-11
HZW9-90105-000	...	F-10-40	HZX2-38552-000	...	F-7-10-11	HZX2-90530-E00	...	F-5-1-19	HZY3-16061-000	...	E-18-12
HZW9-90506-000	...	F-8-10-34	HZX2-41100-C01ZC	...	F-3-10-1	HZX2-90531-C00	...	F-5-18	HZY3-16072-000	...	E-18-13
HZX1-90133-R00	...	F-8-13	HZX2-41100-C11ZC	...	F-3-10-1	HZX2-90531-C00	...	F-5-1-18	HZY3-16073-000	...	E-18-14
HZX2-06125-C00	...	FOP-12-1	HZX2-41100-C21ZC	...	F-3-10-1	HZX2-90531-E00	...	F-5-1-19	HZY3-16074-000	...	E-18-15
HZX2-06131-000	...	E-7-16	HZX2-41100-E01ZC	...	F-3-10-1	HZX2-90541-E01	...	F-5-1-20	HZY3-16075-000	...	E-18-16
HZX2-06192-C00	...	F-4-35	HZX2-41100-E11ZC	...	F-3-10-1	HZX2-90542-E01	...	F-5-1-21	HZY3-16076-000	...	E-18-17
HZX2-06193-C00	...	F-4-36	HZX2-41101-C01ZC	...	F-3-3	HZX2-90651-C00	...	F-5-21	HZY3-16077-000	...	E-18-18
HZX2-11381-003	...	E-6-2	HZX2-41102-E00ZC	...	F-3-5	HZX2-90683-003	...	E-18-1-32	HZY3-16078-000	...	E-18-19
HZX2-11911-000	...	E-3-10-2	HZX2-41107-C00ZC	...	F-3-8	HZX2-90683-003	...	F-7-10-22	HZY3-16082-000	...	E-18-21
HZX2-12000-405ZA	...	E-3-3	HZX2-41110-305ZB	...	F-3-27	HZX2-91051-C01	...	F-5-24	HZY3-16083-000	...	E-18-22
HZX2-13010-000	...	E-7-1	HZX2-41112-C00	...	F-4-14	HZX2-91053-C01	...	F-4-25	HZY3-16087-000	...	E-18-25
HZX2-13011-000	...	E-7-1	HZX2-41112-C10	...	F-4-14	HZX2-91054-E01	...	F-5-1-27	HZY3-16088-000	...	E-18-26
HZX2-13101-000	...	E-7-2	HZX2-41112-C20	...	F-4-14	HZX2-91055-C01	...	F-5-25	HZY3-16176-000	...	E-15-2
HZX2-13102-000	...	E-7-2	HZX2-41131-C00	...	F-4-16	HZX2-91055-C01	...	F-5-1-28	HZY3-16193-A00	...	E-18-10-2
HZX2-13321-003	...	E-7-10	HZX2-41131-E00	...	F-4-16	HZX2-91056-C01	...	F-4-26	HZY3-16196-A00	...	E-18-10-3
HZX2-13322-003	...	E-7-10	HZX2-41140-C00	...	F-5-8	HZX2-91351-C00	...	F-5-30	HZY3-16197-000	...	E-18-10-4
HZX2-13323-003	...	E-7-10	HZX2-41141-E00	...	F-5-1-8	HZX2-91351-C00	...	F-5-1-33	HZY3-16198-A00	...	E-18-10-5
HZX2-13324-003	...	E-7-10	HZX2-41150-E00	...	F-5-1-9	HZX2-91351-C00	...	FOP-12-8	HZY3-16199-A00	...	E-18-10-6
HZX2-13325-003	...	E-7-10	HZX2-41151-C00	...	F-5-9	HZX2-91358-C00	...	F-4-31	HZY3-16203-000	...	E-1-6
HZX2-13326-003	...	E-7-10	HZX2-41161-C00	...	F-5-10	HZY1-91359-C00	...	F-4-32	HZY3-16400-A01	...	E-15-3
HZX2-13341-003	...	E-7-12	HZX2-41161-E00	...	F-5-1-10	HZY1-90205-000	...	F-3-18	HZY3-16405-000	...	E-15-5
HZX2-13342-003	...	E-7-12	HZX2-41200-E00	...	F-5-1-37	HZY1-90205-000	...	F-10-47	HZY3-16451-000	...	E-14-2
HZX2-13343-003	...	E-7-12	HZX2-41201-C00ZC	...	F-5-11	HZY1-90650-003	...	FOP-10-2	HZY3-16611-A00	...	E-14-3
HZX2-13344-003	...	E-7-12	HZX2-41201-C00ZC	...	F-5-1-11	HZY2-87132-R00	...	F-12-4	HZY3-16620-A00	...	E-14-5
HZX2-13345-003	...	E-7-12	HZX2-41202-C00	...	F-5-12	HZY2-87133-R00	...	F-12-11	HZY3-16708-000	...	E-18-28
HZX2-13346-003	...	E-7-12	HZX2-56000-023	...	F-11-13	HZY3-06412-000	...	F-10-2	HZY3-16721-000	...	E-18-31
HZX2-13392-000	...	E-7-14	HZX2-56532-C00	...	F-11-28	HZY3-06532-U00	...	F-10-3	HZY3-16733-000	...	E-18-35
HZX2-13811-000	...	E-13-3	HZX2-58130-T01	...	FOP-8-1	HZY3-11100-415	...	E-3-10-1	HZY3-16734-000	...	E-18-36
HZX2-14111-000	...	E-9-10-1	HZX2-58130-T11	...	FOP-8-1	HZY3-11200-010ZA	...	E-3-1	HZY3-16735-004	...	E-18-37
HZX2-14211-000	...	E-9-10-2	HZX2-58130-T21	...	FOP-8-1	HZY3-11300-C00	...	E-3-2	HZY3-16740-A01	...	E-14-6
HZX2-14526-405ZA	...	E-13-10	HZX2-58130-T31	...	FOP-8-1	HZY3-11311-010ZA	...	E-6-1	HZY3-16751-000	...	E-18-10-7
HZX2-15655-000	...	E-3-15	HZX2-58130-T41	...	FOP-8-1	HZY3-11820-000	...	E-13-10-2	HZY3-16752-000	...	E-18-38
HZX2-16020-003	...	E-18-4	HZX2-58130-T51	...	FOP-8-1	HZY3-11840-010	...	E-13-10-3	HZY3-16752-A00	...	E-14-8
HZX2-16024-003	...	E-18-1-34	HZX2-58130-T61	...	FOP-8-1	HZY3-11861-000	...	E-13-10-4	HZY3-16753-000	...	E-18-1-2
HZX2-16030-003	...	E-18-7	HZX2-58180-T01	...	FOP-8-1	HZY3-11871-000	...	E-13-10-5	HZY3-16754-000	...	E-18-1-3
HZX2-16404-000	...	E-15-4	HZX2-58180-T11	...	FOP-8-1	HZY3-11911-010	...	E-9-1	HZY3-16755-003	...	E-14-9
HZX2-16700-003	...	E-1-7	HZX2-58180-T21	...	FOP-8-1	HZY3-12155-000	...	E-3-5	HZY3-16757-003	...	E-14-10
HZX2-16701-003	...	E-18-27	HZX2-58180-T31	...	FOP-8-1	HZY3-12164-000	...	E-3-6	HZY3-16807-003	...	E-18-1-6
HZX2-16730-003	...	E-18-33	HZX2-58180-T41	...	FOP-8-1	HZY3-12171-305	...	E-3-7	HZY3-16895-C00	...	E-1-9
HZX2-16800-003	...	E-18-1-4	HZX2-58180-T51	...	FOP-8-1	HZY3-12210-010ZA	...	E-9-5	HZY3-16904-003	...	E-18-1-14
HZX2-16805-003	...	E-18-1-5	HZX2-58180-T61	...	FOP-8-1	HZY3-12231-000	...	E-9-7	HZY3-16911-010	...	E-18-39
HZX2-16814-000	...	E-18-1-7	HZX2-63100-R00ZA	...	F-8-2	HZY3-12241-000	...	E-9-8	HZY3-16913-000	...	E-18-40
HZX2-16850-C00	...	F-8-20-1	HZX2-63100-R00ZA	...	F-8-2	HZY3-12251-A01	...	E-9-9	HZY3-16915-010	...	E-18-1-18
HZX2-16860-C00	...	E-18-1-8	HZX2-63100-R01ZA	...	F-8-2	HZY3-12310-405ZA	...	E-1-1	HZY3-16918-003	...	E-18-1-20
HZX2-16870-C00	...	E-1-8	HZX2-63111-C00ZB	...	F-8-6	HZY3-12312-000	...	E-1-2	HZY3-16919-003	...	E-18-1-22
HZX2-16880-C00	...	E-18-1-9	HZX2-63119-C00	...	F-8-7	HZY3-12320-405ZA	...	E-1-3	HZY3-17051-A00	...	E-14-11
HZX2-16890-C00	...	E-18-1-10	HZX2-63260-C00	...	F-8-10-23	HZY3-13331-A04	...	E-7-11	HZY3-17061-000	...	E-14-13
HZX2-16900-003	...	E-18-1-11	HZX2-63710-C00ZB	...	F-3-20-20	HZY3-13391-000	...	E-7-13	HZY3-17105-004	...	E-14-10-1
HZX2-16912-003	...	E-18-1-16	HZX2-63710-C00ZB	...	F-3-20-20	HZY3-13398-003	...	E-7-15	HZY3-17108-000	...	E-14-16
HZX2-16914-000	...	E-18-1-17	HZX2-63710-C01ZB	...	F-3-20-20	HZY3-13621-C01	...	E-13-1	HZY3-17109-004	...	E-14-10-2
HZX2-16940-003	...	E-18-1-24	HZX2-63715-C00ZB	...	F-3-20-21	HZY3-13622-C00	...	E-13-2	HZY3-17110-003	...	E-14-10-3
HZX2-17374-000	...	E-15-9	HZX2-63715-C00ZB	...	F-3-20-21	HZY3-14261-C00	...	E-13-4	HZY3-17113-003	...	E-14-10-4
HZX2-19234-C00	...	F-4-5	HZX2-63715-C01ZB	...	F-3-20-21	HZY3-14270-C00	...	E-13-5	HZY3-17130-003ZA	...	E-14-10-5
HZX2-19241-C00	...	F-4-6	HZX2-63719-C00	...	F-3-20-23	HZY3-14436-000	...	E-9-10-3	HZY3-17138-004	...	E-14-10-6
HZX2-19300-003	...	E-4-10	HZX2-87117-C00	...	F-12-2	HZY3-14510-003	...	E-13-7	HZY3-17721-000	...	E-18-10-12
HZX2-19303-003	...	E-4-11	HZX2-87121-R00	...	F-12-3	HZY3-14515-000	...	E-13-8	HZY3-17723-A01	...	E-18-10-13
HZX2-19313-000ZA	...	E-4-12	HZX2-90001-000	...	E-5-13	HZY3-14520-000	...	E-13-9	HZY3-17724-010	...	E-18-10-14
HZX2-19315-000ZA	...	E-4-13	HZX2-90002-000	...	E-19-21	HZY3-14529-000	...	E-13-11	HZY3-17738-000	...	F-8-20-2

HZY3-17877-000.	F-2-2	HZY3-31242-003.	E-21-13	HZY3-50211-000.	F-10-22	HZY3-90035-000.	E-9-13
HZY3-17910-013.	E-15-10	HZY3-31243-003.	E-21-13	HZY3-50214-000.	F-10-23	HZY3-90036-000.	E-1-18
HZY3-17931-000.	F-2-3	HZY3-31246-003.	E-21-15	HZY3-50301-030ZC.	F-10-24	HZY3-90037-000.	E-15-23
HZY3-18110-010ZA.	E-4-2	HZY3-31247-003.	E-21-16	HZY3-50311-020ZC.	F-10-25	HZY3-90038-000.	E-3-38
HZY3-18115-003.	E-4-3	HZY3-31249-003.	E-21-17	HZY3-50381-000.	F-10-26	HZY3-90039-000.	E-13-26
HZY3-18120-C01ZA.	E-4-4	HZY3-31250-003.	E-21-18	HZY3-50388-U00.	FOP-9-1	HZY3-90040-000.	E-13-27
HZY3-18125-003.	E-4-5	HZY3-31251-003.	E-21-24	HZY3-50388-U10.	FOP-9-2	HZY3-90041-000.	E-3-10-10
HZY3-18141-A00ZA.	E-6-10-2	HZY3-31630-003.	E-19-14	HZY3-50522-000.	F-10-27	HZY3-90042-000.	E-14-22
HZY3-18148-003.	E-6-10-3	HZY3-31630-013.	E-19-14	HZY3-50527-000.	F-10-28	HZY3-90043-000.	E-14-23
HZY3-18149-A01.	E-6-10-4	HZY3-31631-003.	E-19-15	HZY3-50529-000.	F-10-29	HZY3-90044-000.	E-14-24
HZY3-18151-A00ZA.	E-6-10-5	HZY3-31637-000.	E-19-16	HZY3-56100-013.	F-11-14	HZY3-90045-000.	E-6-10-26
HZY3-18330-020.	E-6-3	HZY3-31638-003.	E-13-17	HZY3-56120-013.	F-11-53	HZY3-90046-000.	E-6-10-27
HZY3-18333-003.	E-6-4	HZY3-31639-003.	E-19-17	HZY3-56170-013.	F-11-25	HZY3-90047-000.	E-6-10-28
HZY3-18340-020.	E-6-5	HZY3-31694-003.	E-19-18	HZY3-56516-A00.	F-10-30	HZY3-90049-000.	E-6-10-29
HZY3-19210-003.	F-4-1	HZY3-31710-003.	E-19-19	HZY3-56518-A00.	F-10-31	HZY3-90050-000.	E-18-51
HZY3-19221-010.	F-4-2	HZY3-31750-003.	E-19-20	HZY3-56519-A00.	F-10-32	HZY3-90053-010.	E-6-9
HZY3-19223-000.	F-4-3	HZY3-32111-010.	E-13-18	HZY3-56532-000.	F-11-28	HZY3-90054-000.	E-18-52
HZY3-19231-000.	F-4-4	HZY3-32112-000.	E-14-17	HZY3-56532-000.	F-11-28	HZY3-90055-000.	E-19-24
HZY3-19251-000.	F-4-7	HZY3-32116-000.	E-3-22	HZY3-60180-C01.	F-8-10-12	HZY3-90056-000.	E-18-1-26
HZY3-19251-611.	F-4-7	HZY3-32128-000.	E-14-10-8	HZY3-60185-C01.	F-8-10-13	HZY3-90058-000.	E-14-10-17
HZY3-19251-621.	F-4-7	HZY3-32129-000.	E-1-12	HZY3-63102-010.	F-8-3	HZY3-90059-000.	E-6-10-30
HZY3-19252-000.	E-6-6	HZY3-32193-C00.	E-3-23	HZY3-63107-000.	F-8-4	HZY3-90063-000.	E-3-10-11
HZY3-19253-000.	F-4-8	HZY3-32411-003.	F-7-10-4	HZY3-63108-000.	F-8-5	HZY3-90082-003.	E-3-10-13
HZY3-19254-000.	E-6-7	HZY3-32419-A00.	F-8-10-1	HZY3-63201-000ZC.	F-8-10-14	HZY3-90102-A00.	F-3-20-32
HZY3-19255-000.	E-4-6	HZY3-32421-000.	F-8-10-2	HZY3-63205-000.	F-8-10-15	HZY3-90104-010.	F-10-39
HZY3-19256-010.	E-4-7	HZY3-34754-C00.	E-20-10-5	HZY3-63208-000.	F-8-10-16	HZY3-90105-010.	F-3-20-33
HZY3-19257-000.	E-4-8	HZY3-35476-010.	F-2-19	HZY3-63212-000.	F-8-10-17	HZY3-90106-A00.	F-8-10-31
HZY3-19258-010.	E-18-10-15	HZY3-35477-000.	F-2-20	HZY3-63223-000.	F-8-10-18	HZY3-90107-000.	F-7-10-16
HZY3-19259-000.	E-18-10-16	HZY3-35490-004.	E-3-25	HZY3-63224-000.	F-8-10-19	HZY3-90109-010.	F-8-12
HZY3-19261-000.	E-4-9	HZY3-35640-013.	F-3-20-5	HZY3-63225-000.	F-8-10-20	HZY3-90111-000.	F-3-20-35
HZY3-19270-000.	F-3-20-1	HZY3-35645-000.	F-3-20-6	HZY3-63226-000.	F-8-10-21	HZY3-90113-C00.	F-3-20-36
HZY3-19271-000.	F-3-20-2	HZY3-35655-C01.	E-4-14	HZY3-63230-C00.	F-8-10-22	HZY3-90117-000.	F-10-43
HZY3-19272-000.	F-3-20-3	HZY3-35660-003.	F-10-7	HZY3-63347-C00.	F-3-20-19	HZY3-90120-000.	F-3-14
HZY3-19277-000ZA.	E-6-10-6	HZY3-35673-003.	E-3-26	HZY3-633718-000.	F-3-20-22	HZY3-90122-000.	F-3-20-37
HZY3-19278-000.	E-6-10-7	HZY3-35673-003.	E-4-15	HZY3-63722-010ZC.	F-3-20-24	HZY3-90123-000.	F-5-13
HZY3-19289-000.	F-3-20-4	HZY3-35695-003.	E-13-10-6	HZY3-63728-000.	F-3-20-25	HZY3-90123-000.	F-5-1-13
HZY3-19294-000ZB.	E-6-10-12	HZY3-35700-003.	E-3-27	HZY3-63729-003.	F-8-10-25	HZY3-90124-000.	F-3-15
HZY3-19295-000.	E-6-10-13	HZY3-36123-013.	F-11-7	HZY3-63731-A03ZC.	F-3-20-26	HZY3-90129-A00.	F-3-20-38
HZY3-19296-000.	E-6-10-14	HZY3-36163-003.	E-14-10-10	HZY3-63731-A12ZC.	F-3-20-26	HZY3-90130-620.	F-3-16
HZY3-19297-000.	E-6-10-17	HZY3-36362-000.	E-18-44	HZY3-63736-A03ZC.	F-3-20-27	HZY3-90131-620.	F-3-17
HZY3-19298-000ZB.	E-6-10-18	HZY3-36550-003.	E-15-17	HZY3-63736-A12ZC.	F-3-20-27	HZY3-90132-000.	F-3-20-39
HZY3-19361-000.	E-6-10-19	HZY3-36620-000.	E-18-45	HZY3-63751-C00.	F-3-20-28	HZY3-90134-000.	F-3-20-40
HZY3-19362-000.	E-6-10-20	HZY3-40105-C01.	F-8-10-3	HZY3-63751-C00.	F-3-20-28	HZY3-90204-000.	E-3-10-16
HZY3-19366-000.	E-6-10-21	HZY3-40114-010.	F-3-20-8	HZY3-63751-C01.	F-3-20-56	HZY3-90205-000.	E-14-25
HZY3-23170-030ZA.	E-6-10-22	HZY3-40119-003.	F-8-10-4	HZY3-63756-C00.	F-3-20-29	HZY3-90205-000.	E-14-10-19
HZY3-23172-003.	E-6-20-1	HZY3-40151-000ZC.	F-3-20-9	HZY3-63756-C00.	F-3-20-29	HZY3-90302-000.	F-3-20-42
HZY3-23173-010.	E-6-10-23	HZY3-40154-000ZA.	F-8-10-5	HZY3-63756-C01.	F-3-20-57	HZY3-90304-000.	F-7-10-18
HZY3-24102-000.	F-5-2	HZY3-40155-000.	F-8-10-6	HZY3-90001-000.	E-3-28	HZY3-90405-000.	F-7-10-19
HZY3-24102-000.	F-5-1-2	HZY3-40157-000.	F-8-10-7	HZY3-90002-000.	E-21-19	HZY3-90406-000.	E-1-20
HZY3-24103-000.	F-5-3	HZY3-40158-000.	F-8-10-8	HZY3-90003-000.	E-21-20	HZY3-90501-A00.	F-10-54
HZY3-24103-000.	F-5-1-3	HZY3-40159-000.	F-8-10-9	HZY3-90006-003.	E-3-29	HZY3-90503-610.	F-3-20-43
HZY3-24113-A01.	F-5-4	HZY3-40201-020ZC.	F-3-20-10	HZY3-90007-000.	E-13-10-7	HZY3-90504-A00.	F-10-57
HZY3-24113-A01.	F-5-1-4	HZY3-40201-612ZC.	F-3-20-10	HZY3-90008-003.	E-3-30	HZY3-90504-A00.	F-10-57
HZY3-24122-A01.	F-5-5	HZY3-40202-621ZC.	F-3-2	HZY3-90009-003.	E-3-31	HZY3-90506-000.	F-5-15
HZY3-24122-A01.	F-5-1-5	HZY3-40204-000.	F-4-13	HZY3-90010-000.	E-6-20-3	HZY3-90506-000.	F-5-1-15
HZY3-24123-000.	F-5-6	HZY3-40210-610.	F-3-20-12	HZY3-90011-000.	E-6-20-4	HZY3-90507-000.	F-8-15
HZY3-24123-000.	F-5-1-6	HZY3-40212-010ZC.	F-3-20-13	HZY3-90013-000.	E-6-20-5	HZY3-90508-000.	E-15-24
HZY3-24124-310.	F-5-7	HZY3-40212-611ZC.	F-3-20-13	HZY3-90015-000.	E-6-20-6	HZY3-90508-000.	F-2-33
HZY3-24124-310.	F-5-1-7	HZY3-40219-013.	F-10-9	HZY3-90017-000.	E-3-33	HZY3-90509-000.	F-10-58
HZY3-24221-000.	F-2-6	HZY3-40219-013.	F-11-11	HZY3-90017-000.	E-13-23	HZY3-90510-000.	F-10-59
HZY3-24310-C00.	F-4-9	HZY3-40225-010.	F-3-20-14	HZY3-90017-000.	E-18-49	HZY3-90511-000.	F-3-20-44
HZY3-24310-E00.	F-4-9	HZY3-40225-010.	F-3-20-14	HZY3-90017-000.	E-19-23	HZY3-90512-000.	F-5-17
HZY3-24318-000.	F-4-10	HZY3-40226-010.	F-3-20-15	HZY3-90017-000.	F-2-23	HZY3-90512-000.	F-5-1-17
HZY3-24320-A20.	F-4-11	HZY3-40226-010.	F-3-20-15	HZY3-90018-000.	E-13-10-9	HZY3-90548-000.	F-5-19
HZY3-24610-A00.	F-2-8	HZY3-41104-C01.	F-3-6	HZY3-90021-000.	E-3-35	HZY3-90549-000.	F-5-19
HZY3-24612-010.	F-2-9	HZY3-41105-C01.	F-3-7	HZY3-90021-000.	E-14-21	HZY3-90550-000.	F-5-19
HZY3-24613-000.	F-2-10	HZY3-41116-000.	F-4-15	HZY3-90021-000.	E-18-50	HZY3-90551-000.	F-5-19
HZY3-24617-000.	F-2-11	HZY3-41179-A00.	F-10-12	HZY3-90021-000.	F-8-10-27	HZY3-90552-000.	F-5-19
HZY3-24618-000.	F-2-12	HZY3-50100-A01.	F-10-13	HZY3-90023-000.	E-14-10-14	HZY3-90553-000.	F-5-19
HZY3-24619-000.	F-2-13	HZY3-50100-A11.	F-10-13	HZY3-90026-000.	E-9-12	HZY3-90554-000.	F-5-19
HZY3-24620-000.	F-2-14	HZY3-50109-000.	F-10-14	HZY3-90027-000.	E-4-17	HZY3-90555-000.	F-5-19
HZY3-24623-000.	F-2-15	HZY3-50111-020.	F-3-20-16	HZY3-90028-000.	E-3-36	HZY3-90556-000.	F-5-19
HZY3-24628-000.	F-2-16	HZY3-50151-000.	F-10-15	HZY3-90029-000.	E-14-10-15	HZY3-90557-000.	F-5-19
HZY3-31116-000.	E-5-12	HZY3-50153-000.	F-10-16	HZY3-90030-000.	E-3-37	HZY3-90558-000.	F-5-19
HZY3-31200-003.	E-21-1	HZY3-50155-000.	F-3-20-17	HZY3-90030-000.	E-3-10-8	HZY3-90559-000.	F-5-19
HZY3-31207-003.	E-21-3	HZY3-50157-010.	F-3-20-18	HZY3-90030-000.	E-6-10-24	HZY3-90560-000.	F-5-19
HZY3-31216-003.	E-21-5	HZY3-50161-000ZD.	F-10-17	HZY3-90030-000.	E-13-24	HZY3-90601-030.	E-4-20
HZY3-31226-003.	E-21-7	HZY3-50161-610.	F-10-17	HZY3-90030-000.	E-15-21	HZY3-90601-030.	E-18-10-25
HZY3-31232-003.	E-21-9	HZY3-50166-000.	F-10-18	HZY3-90031-000.	E-3-10-9	HZY3-90602-020.	E-1-21
HZY3-31235-003.	E-21-10	HZY3-50168-000.	F-10-19	HZY3-90031-000.	E-6-10-25	HZY3-90603-020.	E-4-21
HZY3-31236-003.	E-21-11	HZY3-50201-C01ZD.	F-10-20	HZY3-90031-000.	E-14-10-16	HZY3-90604-020.	E-4-22
HZY3-31240-003.	E-21-12	HZY3-50201-C11ZC.	F-10-20	HZY3-90034-000.	E-4-18	HZY3-90652-000.	F-3-20-48
HZY3-31241-003.	E-21-12	HZY3-50209-A00.	F-10-21	HZY3-90034-000.	E-15-22	HZY3-90653-003.	F-7-4

HZY3-90741-000. E-13-29
HZY3-90751-000. F-2-36
HZY3-90752-003. F-4-23
HZY3-91001-003. E-6-10-34
HZY3-91056-711. F-5-26
HZY3-91056-711. F-5-1-29
HZY3-91057-003. F-5-27
HZY3-91057-003. F-5-1-30
HZY3-91151-000. F-5-28
HZY3-91151-000. F-5-1-31
HZY3-91152-003. F-2-37
HZY3-91212-003. E-3-42
HZY3-91251-C01 F-4-27
HZY3-91251-C01 FOP-12-3
HZY3-91254-003. F-4-28
HZY3-91254-003. FOP-12-5
HZY3-91255-003. F-2-39
HZY3-91301-003. E-4-23
HZY3-91303-000. E-21-23
HZY3-91304-000. E-6-10-37
HZY3-91305-003. E-6-10-38
HZY3-91306-003. E-6-10-39
HZY3-91356-003. F-4-30
HZY3-91401-A00 E-1-25
HZY3-91402-020. E-1-26
HZY3-91403-000. E-1-27
HZY3-91404-000. E-6-10-40
HZY3-91405-000. E-6-10-41
HZY3-91451-000. F-3-20-51
HZY3-91508-000. E-13-10-10
HZY3-91551-000. F-4-33
HZY3-91552-000. F-3-20-52
HZY3-91556-000. F-8-16
HZY3-91560-000. F-10-71
HZY3-91651-003. F-3-20-54
HZY6-16450-003. E-14-1
HZY6-16718-013. E-18-30
HZY6-16723-003. E-18-32
HZY6-19269-000. E-18-10-17
HZY6-24320-000. F-4-11
HZY6-24320-610. F-4-11
HZY6-32371-004. F-7-20-2
HZY6-32414-640. F-7-10-6
HZY6-36135-003. E-18-10-18
HZY6-38235-004. F-7-20-4
HZY6-39794-003. F-7-20-6
HZY6-90103-000. F-3-12
HZY6-90103-000. F-10-38
HZY6-90135-004. F-7-20-8
HZY6-91553-000. F-3-20-52
HZY9-17315-000. E-15-8
HZY9-30419-003. E-20-1
HZY9-30419-003. E-20-10-2
HZY9-30419-003. F-7-10-1
HZY9-31207-H01 E-21-3
HZY9-31226-H01 E-21-21
HZY9-31229-H01 E-21-8
HZY9-31246-H01 E-21-15
HZY9-32103-000. F-7-10-2
HZY9-38553-003. E-20-10-6
HZY9-56115-003. F-11-52
HZY9-90017-000. E-15-20
HZY9-90105-000. E-20-4
HZZ0-56539-C00 F-10-33
HZZ0-90101-000. F-3-11
HZZ3-06240-R30 FOP-1-1
HZZ3-06240-R40 FOP-1-4-1
HZZ3-06240-R60 FOP-1-2-1
HZZ3-06323-R20 FOP-7-1
HZZ3-06323-R30 FOP-7-1-1
HZZ3-06328-763. FOP-10-1
HZZ3-24800-P12. FOP-1-7-1
HZZ3-24800-R00 FOP-1-6-1
HZZ3-24820-R11 FOP-1-13
HZZ3-24820-R21 FOP-1-2-14
HZZ3-24830-R41 FOP-1-4-11
HZZ3-32101-000. E-20-10-3
HZZ3-32127-000. F-7-2
HZZ3-32341-R31 FOP-7-3
HZZ3-32346-R21 FOP-7-4
HZZ3-32346-R31 FOP-7-1-3
HZZ3-32347-R01 FOP-7-5
HZZ3-35100-R11 FOP-1-6-38

HZZ3-35100-R11 FOP-1-7-33
HZZ3-35100-R11 FOP-7-9
HZZ3-35100-R11 FOP-7-1-7
HZZ3-35645-A41 FOP-1-7-35
HZZ3-37205-R01 FOP-7-13
HZZ3-87301-R00 F-12-12
HZZ3-87701-R00 FOP-1-6-47
HZZ3-87701-R40 FOP-1-4-18
HZZ3-87703-R01 FOP-1-2-24
HZZ3-87703-R81 FOP-1-21
HZZ3-91252-003. F-5-29
HZZ3-91252-003. F-5-1-32
HZZ3-91252-003. FOP-12-4
HZZ5-06325-600. FOP-13-1
HZZ5-06325-700. FOP-13-1
HZZ5-06325-800. FOP-13-1
HZZ5-16901-003. E-18-1-12
HZZ5-16906-003. E-18-1-15
HZZ5-16915-000. E-18-1-19
HZZ5-16918-003. E-18-1-21
HZZ5-16919-003. E-18-1-23
HZZ5-24810-D01 FOP-1-7-2
HZZ5-24811-D01 FOP-1-7-3
HZZ5-24812-D01 FOP-1-7-4
HZZ5-24813-D01 FOP-1-7-5
HZZ5-24814-D01 FOP-1-7-6
HZZ5-24815-D01 FOP-1-7-7
HZZ5-24816-D01 FOP-1-7-8
HZZ5-24817-D01 FOP-1-7-9
HZZ5-24818-D01 FOP-1-7-10
HZZ5-24819-D01 FOP-1-7-11
HZZ5-24821-D01 FOP-1-7-12
HZZ5-24822-D01 FOP-1-7-13
HZZ5-24823-D01 FOP-1-7-14
HZZ5-24824-D01 FOP-1-7-15
HZZ5-24826-D01 FOP-1-7-16
HZZ5-24827-D01 FOP-1-7-17
HZZ5-24828-D01 FOP-1-7-18
HZZ5-24828-D01 FOP-1-7-74
HZZ5-24829-D01 FOP-1-7-19
HZZ5-24831-D01 FOP-1-7-20
HZZ5-24832-D01 FOP-1-7-21
HZZ5-24833-D01 FOP-1-7-22
HZZ5-24845-D01 FOP-1-7-23
HZZ5-24850-D01 FOP-1-7-24
HZZ5-24855-D01 FOP-1-7-25
HZZ5-24875-D01 FOP-1-7-26
HZZ5-24876-D01 FOP-1-7-27
HZZ5-24878-D01 FOP-1-7-28
HZZ5-24883-D01 FOP-1-7-29
HZZ5-32185-600. FOP-13-2
HZZ5-32185-700. FOP-13-2
HZZ5-32185-800. FOP-13-2
HZZ5-32530-000. FOP-1-6-34
HZZ5-32530-D01 FOP-1-7-30
HZZ5-32545-000. FOP-7-6
HZZ5-32545-000. FOP-7-1-4
HZZ5-32580-600. FOP-13-3
HZZ5-32580-700. FOP-13-3
HZZ5-32580-800. FOP-13-3
HZZ5-32580-D01 FOP-13-3
HZZ5-32580-D11 FOP-13-3
HZZ5-32580-D21 FOP-13-3
HZZ5-35370-D02 FOP-1-7-34
HZZ5-35701-D01 FOP-1-7-36
HZZ5-37210-013. FOP-1-6-44
HZZ5-37210-712. FOP-7-1-11
HZZ5-37210-762. FOP-7-14
HZZ5-37210-D01 FOP-1-7-39
HZZ5-38414-003. FOP-7-17
HZZ5-38414-003. FOP-7-1-14
HZZ5-87701-D00 FOP-1-7-42
HZZ5-87702-A00 FOP-1-7-43
HZZ5-87702-A00 FOP-1-7-72
HZZ5-87703-P00. FOP-1-7-44
HZZ5-87704-D01 FOP-1-7-45
HZZ5-90101-D01 FOP-1-7-46
HZZ5-90102-D01 FOP-1-7-47
HZZ5-90103-D01 FOP-1-7-48
HZZ5-90104-D01 FOP-1-7-49
HZZ5-90106-D01 FOP-1-7-50
HZZ5-90107-D01 FOP-1-7-51
HZZ5-90108-D01 FOP-1-7-52

HZZ5-90109-D01 FOP-1-7-53
HZZ5-90301-D01 FOP-1-7-54
HZZ5-90302-D01 FOP-1-7-56
HZZ5-90501-D01 FOP-1-7-57
HZZ5-90502-D01 FOP-1-7-58
HZZ5-90503-D01 FOP-1-7-59
HZZ5-90504-D01 FOP-1-7-60
HZZ5-90506-D01 FOP-1-7-61
HZZ5-90507-D01 FOP-1-7-62
HZZ5-90508-D01 FOP-1-7-63
HZZ5-90509-D01 FOP-1-7-64
HZZ5-90651-D01 FOP-1-7-65
HZZ5-91151-D01 FOP-1-7-66
HZZ5-91152-D01 FOP-1-7-67
HZZ5-91153-D01 FOP-1-7-68
HZZ5-91154-D01 FOP-1-7-69
HZZ5-91156-D01 FOP-1-7-70
HZZ5-91157-D01 FOP-1-7-71
HZZ5-91501-000. F-7-10-23

Note

Note

Note

Note

2018 PARTS CATALOG

BFT 250A Model

OB No.002-14ZX2-0AH 1712 US

TOHATSU CORPORATION

5-4, Azusawa 3-Chome, Itabashi-Ku
Tokyo 174-0051, Japan
Tel: +81-3-3966-3117 Fax: +81-3-3966-2951
www.tohatsu.com

