

# 2015 PARTS CATALOG

**TOHATSU**

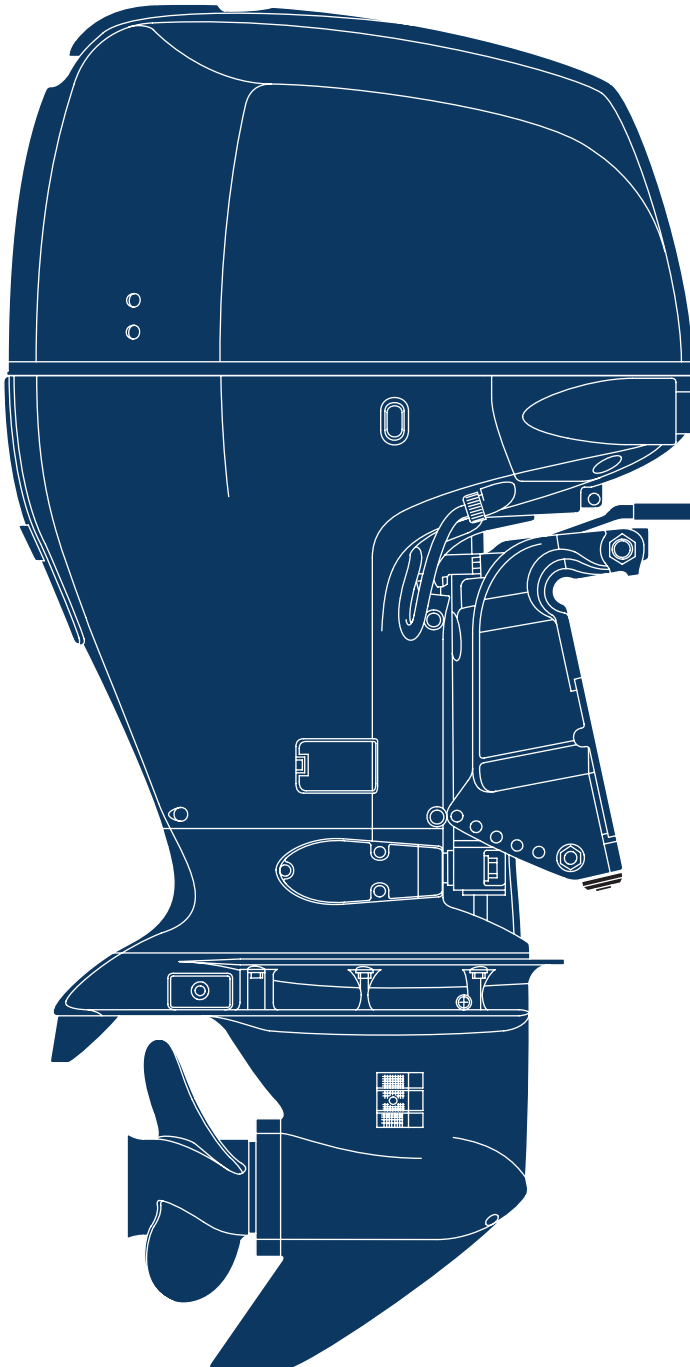

## BFT 150A

OB NO.002-14ZY6-1  
1411US



# Instruction for use of parts catalogue

- **This parts catalogue was prepared based on the latest information available as of October 1, 2014.**
- See the Service Bulletin for any revision that is made after October 1, 2014.
- **Always specify the part number when ordering a part.**
  - Check the model, type, serial numbers, color, maker, and the size as needed before ordering a part.
  - Note that the illustrations (part drawings) can differ from the actual parts in shape.  
Illustrations are given just to help you to refer to the parts.
- **When modifications or additions to this parts catalogue are made, a revised edition will be issued at an appropriate time, with successively progressing revision numbers on the cover. We recommend obtaining such revisions in order to keep your parts catalogue up-to-date at all times.**

**Initial version issue date October 1, 2014**

## CONTENTS

E-1	CYLINDER HEAD COVER	1
E-3	CYLINDER BLOCK	3
E-4	EXHAUST MANIFOLD	7
E-4-10	WATER HOSE	9
E-5	OIL PUMP/FLYWHEEL	11
E-6	OIL PAN	13
E-7	CRANKSHAFT/PISTON	17
E-9	CAMSHAFT/VALVE	21
E-9-10	CHAIN CASE/THERMOSTAT	25
E-9-20	CYLINDER HEAD	27
E-10	BALANCER SHAFT	31
E-13	SILENCER DUCT	33
E-14	INTAKE MANIFOLD/INJECTOR	35
E-15	THROTTLE BODY	39
E-18	FUEL PUMP/FUEL HOSE	41
E-18-1	WATER SEPARATOR	45
E-18-10	VAPOR SEPARATOR ASSY	47
E-19	A.C. GENERATOR	51
E-20	IGNITION COIL/PLUG	55
E-20-10	ELECTRONIC CONTROL UNIT	57
E-21	STARTER MOTOR	59
F-2	SHIFT SHAFT	63
F-3	GEAR CASE	67
F-3-10	GEAR CASE ASSY	69
F-3-20	EXTENSION CASE	71
F-4	WATER PUMP/VERTICAL SHAFT	73
F-5	PROPELLER SHAFT/PROPELLER	77
F-5-1	PROPELLER SHAFT/PROPELLER (COUNTER ROTATION)	81
F-6	FUEL TUBE (1)	85
F-7	WIRE HARNESS	87
F-7-10	STARTER CABLE	89
F-7-20	FUSE BOX/RELAY	91
F-7-30	CLAMP	93
F-8	ENGINE COVER ASSY	95
F-8-10	FR. COVER BRACKET/FR. LOCK	97
F-8-20	UNDER COVER	99
F-9	FUEL TUBE (2)	101
F-10	STERN BRACKET/SWIVEL CASE	103
F-11	POWER TRIM-TILT	109
F-12	LABELS	113
F-13	TOOLS	115
FOP-2	METER	117
FOP-6	CONTROL PANEL (1)	119
FOP-6-1	CONTROL PANEL (2)	123
FOP-7	TRIM ADJUST PLATE SET	125
FOP-8	REMOTE CONTROL (TOP MOUNT SINGLE TYPE) (RIGHT)	127
FOP-8-2	REMOTE CONTROL (TOP MOUNT DUAL TYPE) (RIGHT)	131
FOP-8-4	REMOTE CONTROL (FLUSH MOUNT TYPE) (RIGHT)	135
FOP-8-6	REMOTE CONTROL	137
FOP-9	BOLT KIT	143
FOP-10	WATER PUMP IMPELLER KIT (1)	145
FOP-10-1	WATER PUMP IMPELLER KIT (2)	147
FOP-11	INTERFACE CABLE KIT	149
FOP-12	TROLLING CONTROL SWITCH	151
INDEX		153
INDEX (Parts Number)		159





# How to check the part block and serial numbers

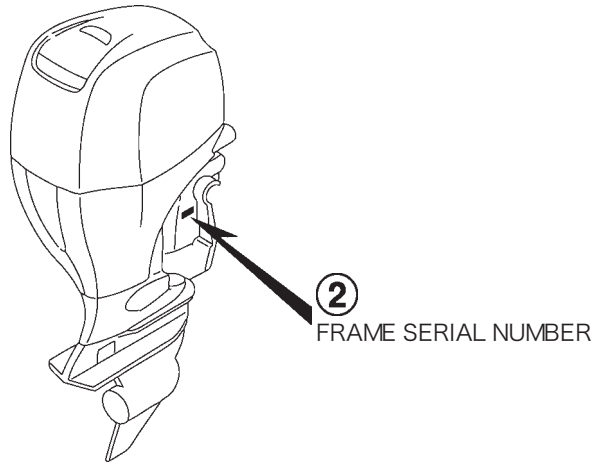
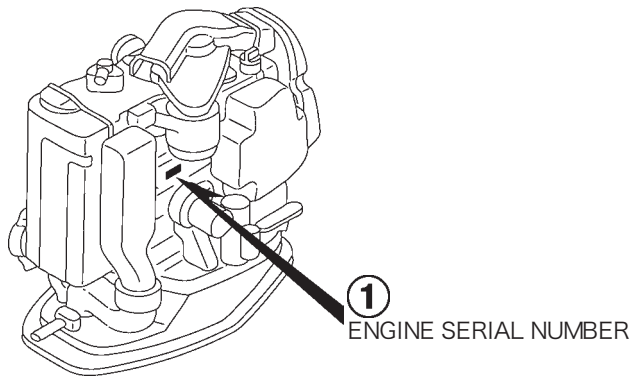
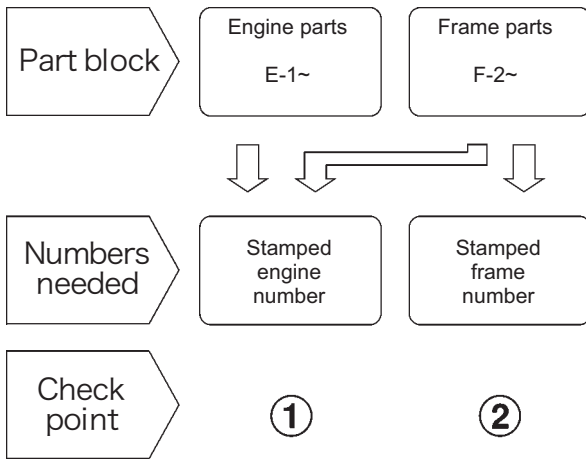

## Models, parts catalogue codes and applicable serial numbers

- Models, parts catalogue codes and applicable serial Nos. given in this parts catalogue can be identified as follows.

Model	Type	Parts catalogue type	Engine		Applicable engine serial No.	Applicable frame serial No.
			Model	Type		
BFT150A	LA	LA	BF150A4	SE	BEANJ-1000001~	BANJ-6000261~
	XA	XA				
	XCA	XCA			BEANJ-1000001~	BAPJ-7000013~

## Features of each type

- See the following table for the features of each type. (Items in brackets are optional)

Specifications		Model	BFT 150A4		
		Type	LA	XA	XCA
Transom height	508 mm	●			
	635 mm		●	●	
Counter rotation				●	
Remote control		(●)	(●)	(●)	
Fuel tank		(●)	(●)	(●)	
Power tilt		●	●	●	
Propeller	14-1/2 x 15	(●)	(●)	(●)	
	14-1/4 x 17	(●)	(●)	(●)	
	14 x 19	(●)	(●)	(●)	
	14-3/4 x 19	(●)	(●)		
	14 x 21	(●)	(●)	(●)	
	14-1/2 x 21	(●)	(●)		
	14-1/2 x 23	(●)	(●)	(●)	
	14-1/4 x 23	(●)	(●)		
	14 x 25	(●)	(●)		
	15-1/2 x 13	(●)	(●)		
	15-1/4 x 15	(●)	(●)		
	15 x 17	(●)	(●)		



# Fuel hose, general purpose hoses and vinyl hose

- The standard part fuel hose, general purpose hose and vinyl hose may be substituted by the coiled bulk part.
- When ordering the standard part fuel hose, general purpose hose and vinyl hose use the bulk part number written in the parts catalog in brackets ( ) underneath the part name.
- When exchanging the hose, cut and use at the specified length as mentioned in the part name. (For the method of cutting the bulk part, and method of filling out orders etc., please refer to the instructions issued with the bulk part.)

## Bulk part number of fuel hose, general purpose hose and vinyl hose.

Example: 95001-75001-50M

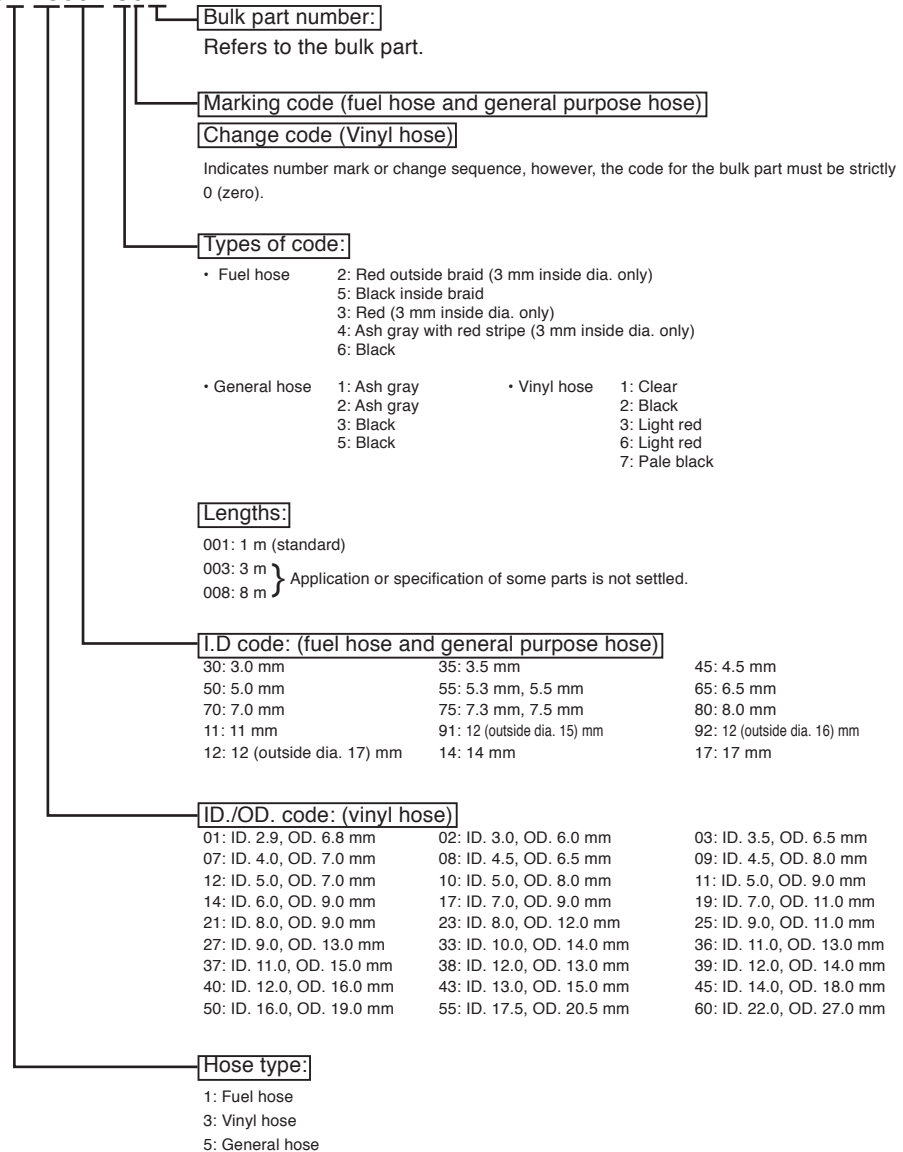

## CAUTION: It is DANGEROUS to confuse the fuel hose with the general purpose hose or vinyl hose.

Never use a general purpose hose or vinyl hose in place of a fuel hose or vice versa. Always use the correct bulk part in the parts catalogue, according to the service manual or the instructions issued with the bulk part.

E-1 CYLINDER HEAD COVER

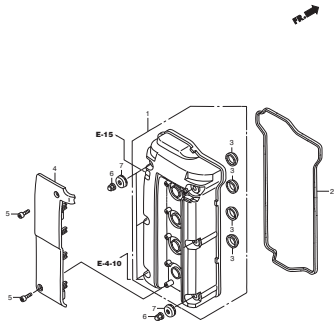

E-3 CYLINDER BLOCK

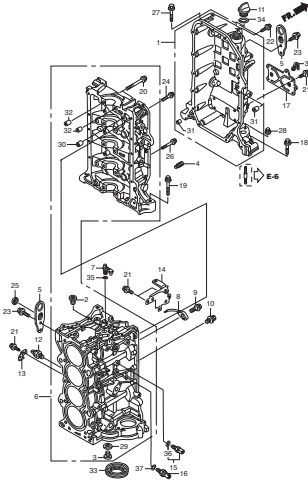

E-4 EXHAUST MANIFOLD

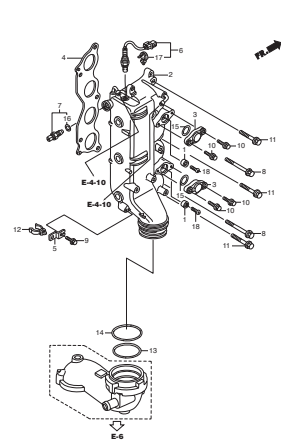

E-4-10 WATER HOSE

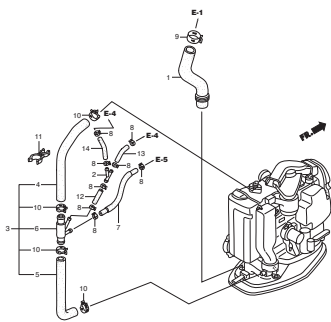

E-5 OIL PUMP/FLYWHEEL

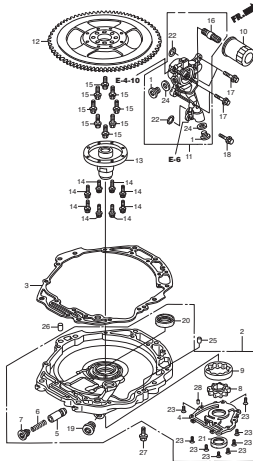

E-6 OIL PAN

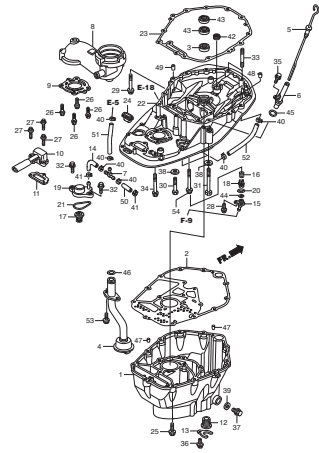

E-7 CRANKSHAFT/PISTON

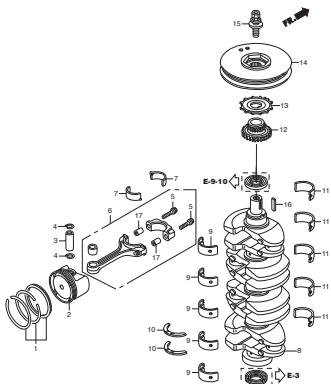

E-9 CAMSHAFT/VALVE

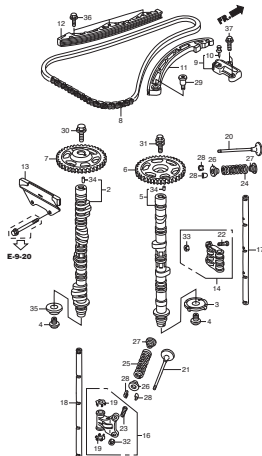

E-9-10 CHAIN CASE/THERMOSTAT

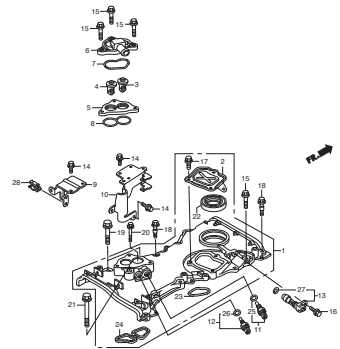

E-9-20 CYLINDER HEAD

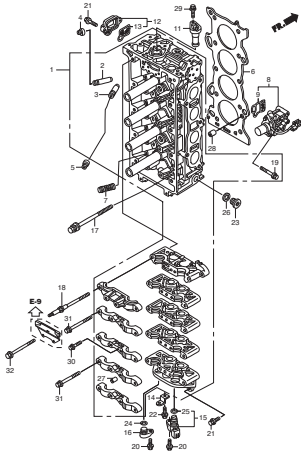

E-10 BALANCER SHAFT

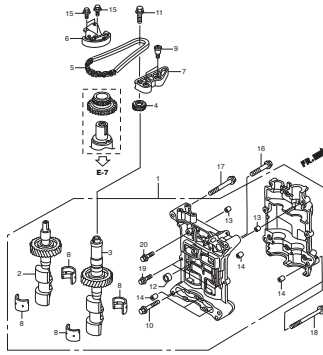

E-13 SILENCER DUCT

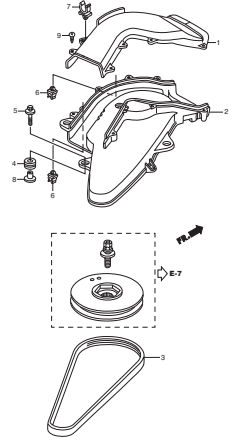

E-14 INTAKE MANIFOLD/INJECTOR

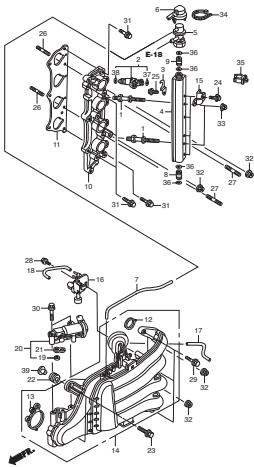

E-15 THROTTLE BODY

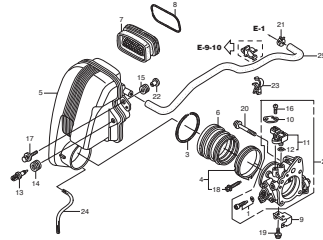

E-18 FUEL PUMP/FUEL HOSE

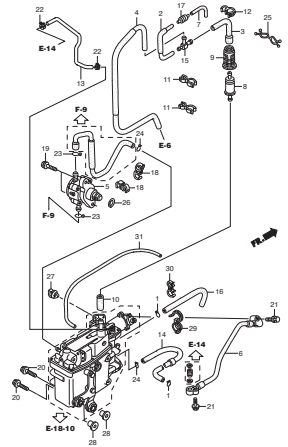

E-18-1 WATER SEPARATOR

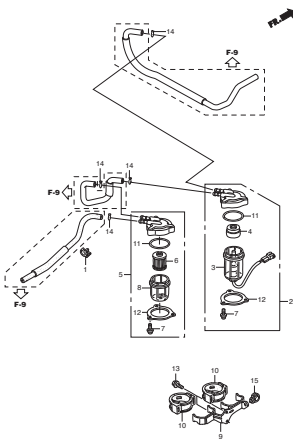

E-18-10 VAPOR SEPARATOR ASSY

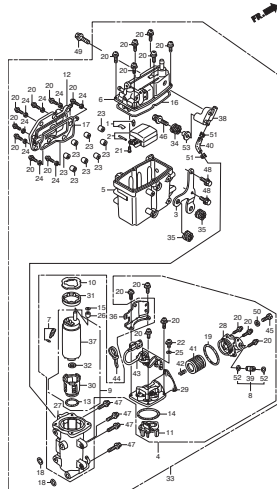

E-19 A.C. GENERATOR

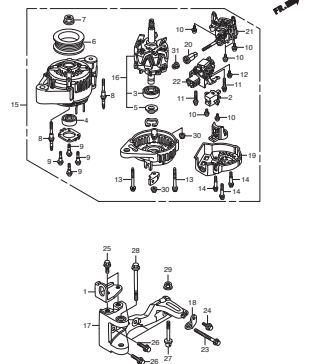

E-20 IGNITION COIL/PLUG

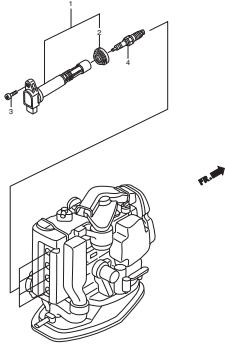

E-20-10 ELECTRONIC CONTROL UNIT

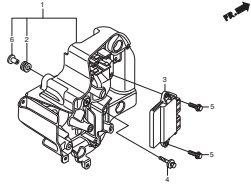

E-21 STARTER MOTOR

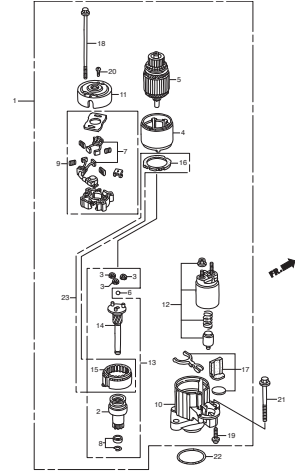

F-2 SHIFT SHAFT

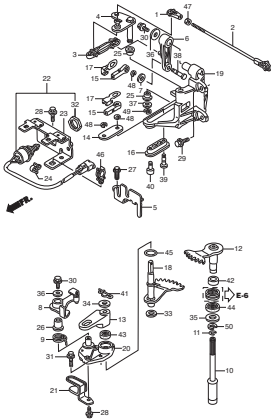

F-3 GEAR CASE

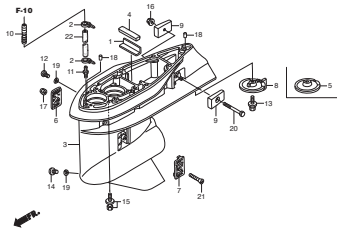

F-3-10 GEAR CASE ASSY

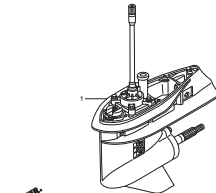

F-3-20 EXTENSION CASE

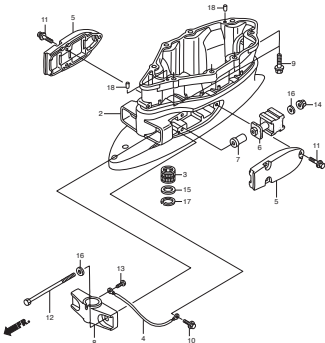

F-4 WATER PUMP/VERTICAL SHAFT

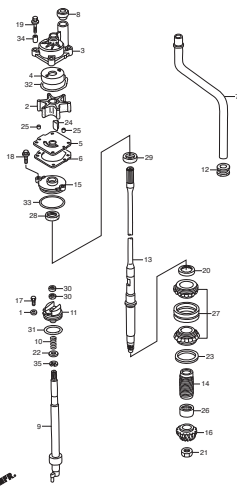

F-5 PROPELLER SHAFT/PROPELLER

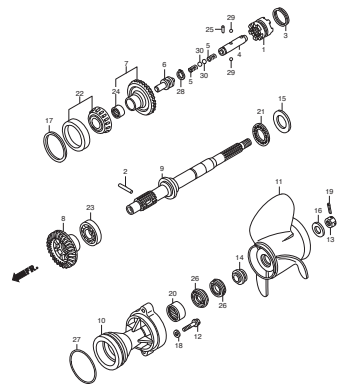

**F-5-1 PROPELLER SHAFT/PROPELLER  
(COUNTER ROTATION)**

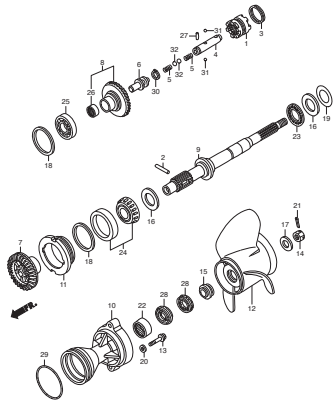

**F-6 FUEL TUBE (1)**

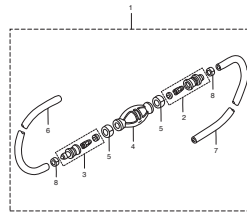

**F-7 WIRE HARNESS**

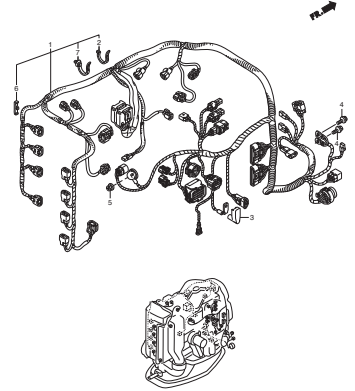

**F-7-10 STARTER CABLE**

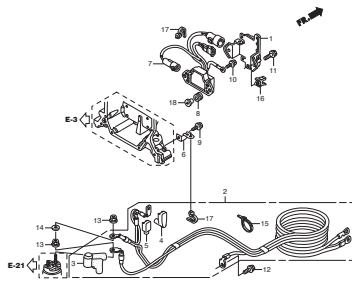

**F-7-20 FUSE BOX/RELAY**

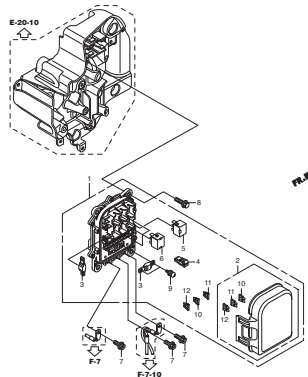

**F-7-30 CLAMP**

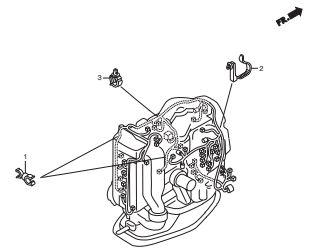

**F-8 ENGINE COVER ASSY**

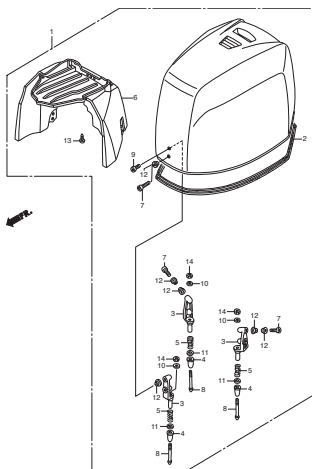

**F-8-10 FR. COVER BRACKET/FR. LOCK**

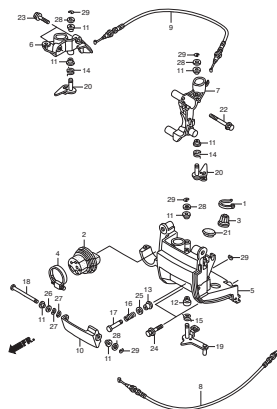

**F-8-20 UNDER COVER**

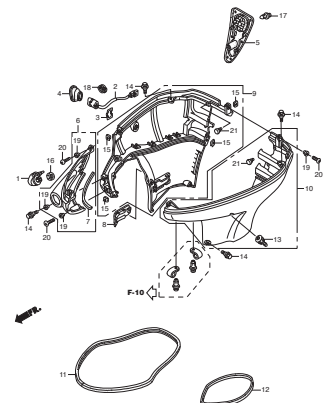

F-9 FUEL TUBE (2)

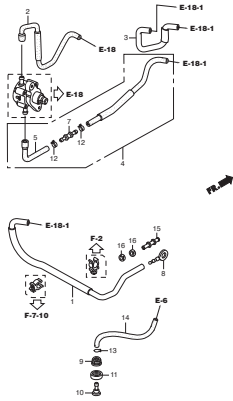

F-10 STERN BRACKET/SWIVEL CASE

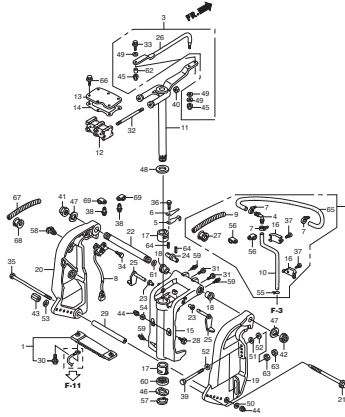

F-11 POWER TRIM-TILT

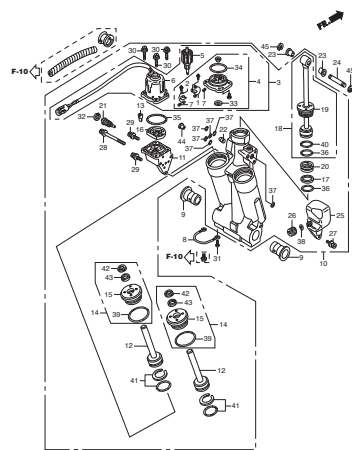

F-12 LABELS

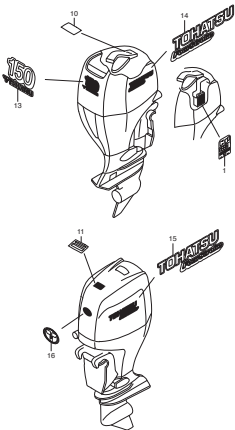

F-13 TOOLS

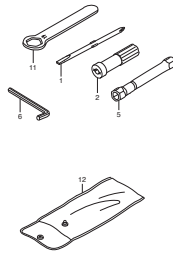

FOP-2 METER

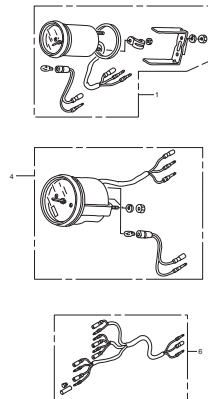

FOP-6 CONTROL PANEL (1)

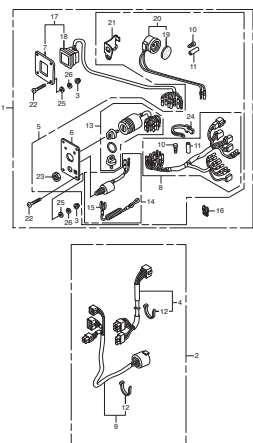

FOP-6-1 CONTROL PANEL (2)

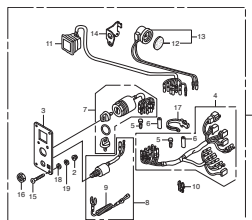

FOP-7 TRIM ADJUST PLATE SET

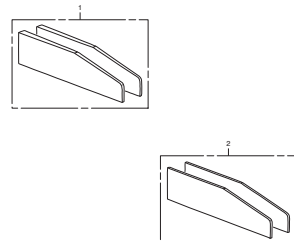

**FOP-8 REMOTE CONTROL  
(TOP MOUNT SINGLE TYPE) (RIGHT)**

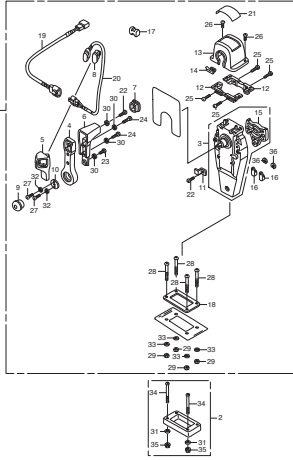

**FOP-8-2 REMOTE CONTROL  
(TOP MOUNT DUAL TYPE) (RIGHT)**

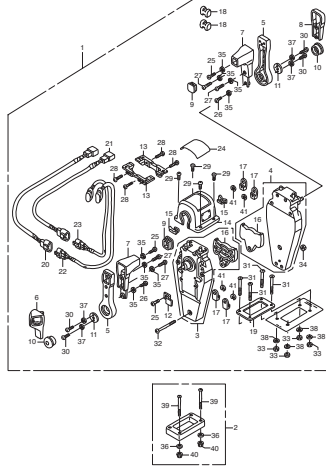

**FOP-8-4 REMOTE CONTROL  
(FLUSH MOUNT TYPE) (RIGHT)**

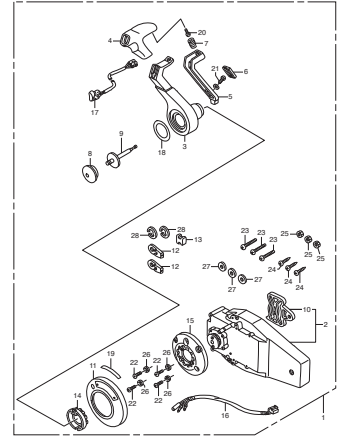

**FOP-8-6 REMOTE CONTROL**

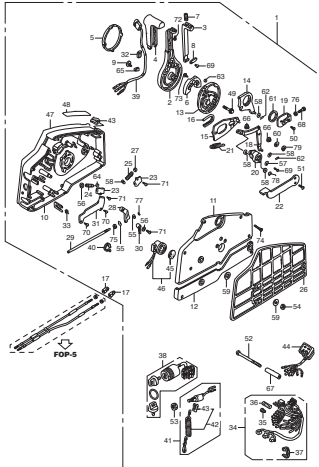

**FOP-9 BOLT KIT**

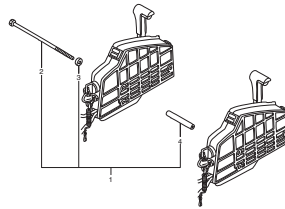

**FOP-10 WATER PUMP IMPELLER KIT (1)**

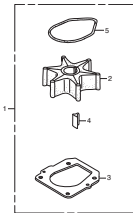

**FOP-10-1 WATER PUMP IMPELLER KIT (2)**

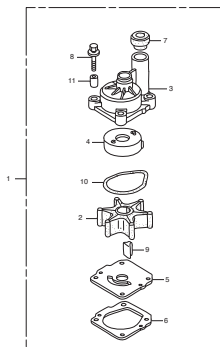

**FOP-11 INTERFACE CABLE KIT**

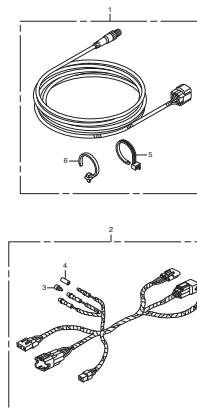

**FOP-12 TROLLING CONTROL SWITCH**

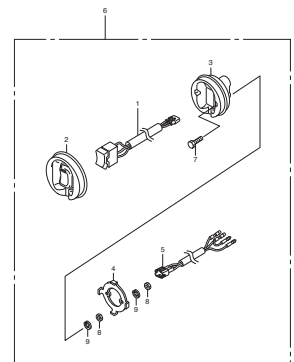

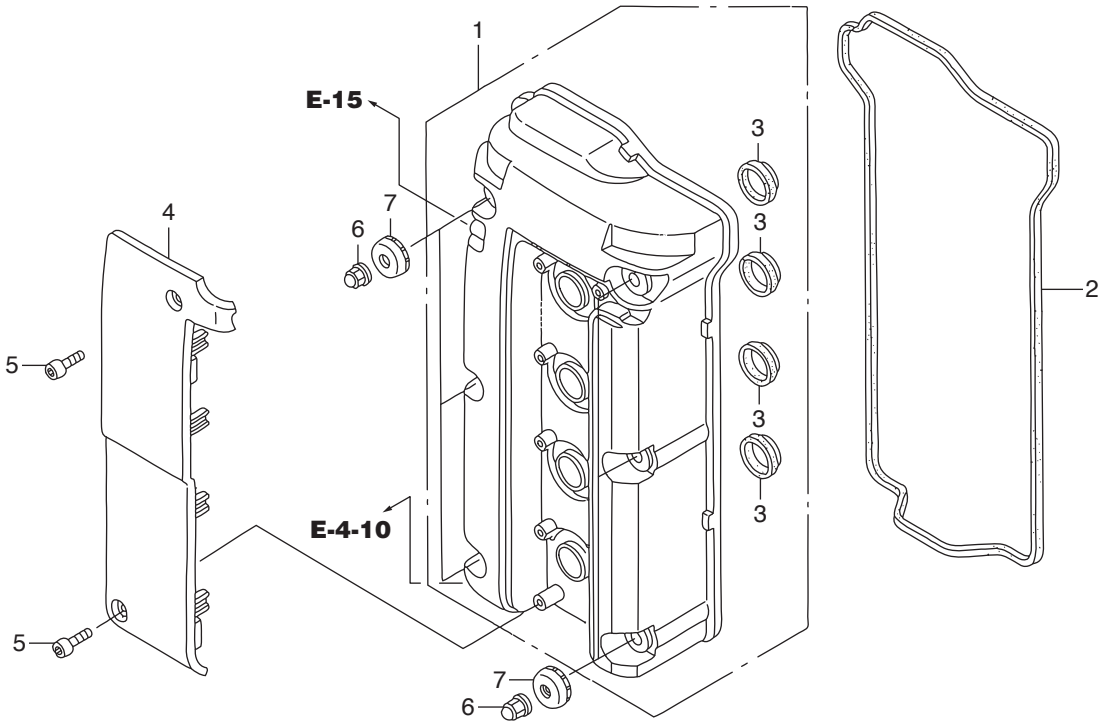





E-3

CYLINDER BLOCK

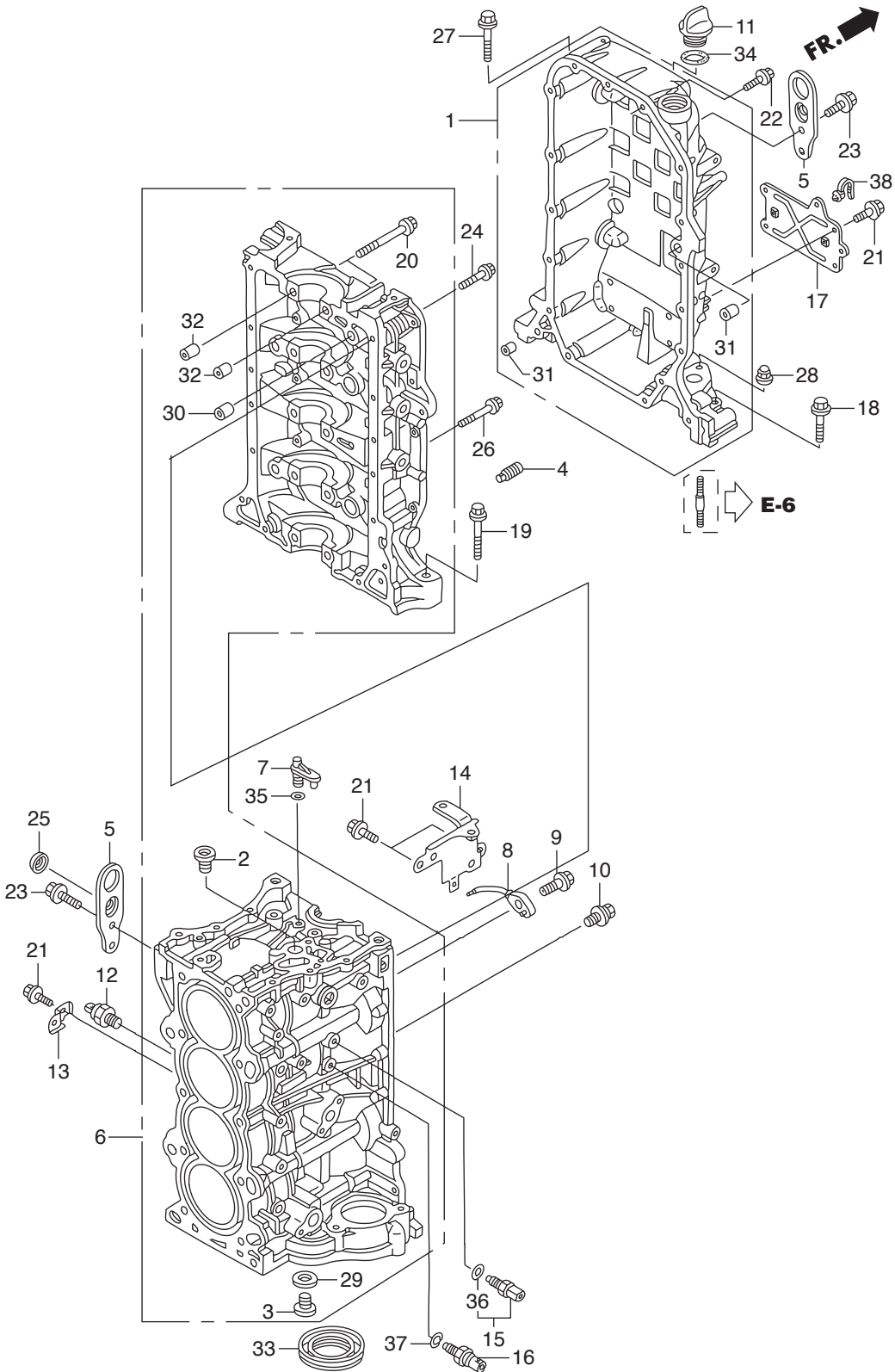

Ref.No.	Part No.	Description	Q' ty	Remarks	
			BFT150A		
E-3	1	HZY6-11100-405	CRANKCASE COMP.	1	
E-3	2	HPNA-11106-300	BOLT, SEALING, 20MM	1	
E-3	3	HPR4-11106-013	BOLT, SEALING, 28MM	1	
E-3	4	HPNA-11135-000	ORIFICE, LOWER BLOCK	1	
E-3	5	HZY6-11911-000	HANGER, ENGINE	2	
E-3	6	HZY6-12000-415ZA	BLOCK ASSY., CYLINDER	1	*NH8* DARK GRAY
E-3	7	HZY6-15152-000	ORIFICE, OIL JET	1	
E-3	8	HPRB-15280-A00	BODY COMP., OIL JET	2	
E-3	9	HPRA-15290-000	BOLT COMP., OIL JET	2	
E-3	10	HZY6-15299-000	BOLT-WASHER, 8X10	2	
E-3	11	H921-15611-000	CAP, OIL(YELLOW)	1	
E-3	12	HZY6-30530-003	SENSOR ASSY., KNOCK	1	
E-3	13	HZW9-32114-730	BRACKET, CLIP B	1	
E-3	14	HZY6-32114-010	BRACKET D, HARNESS CLIP	1	
E-3	15	HZY3-35673-003	SENSOR ASSY., WATER	1	TEMPERATURE
E-3	16	HRNA-37260-A01	SENSOR, OIL PRESSURE	1	
E-3	17	HZY6-38552-000	BRACKET, RELAY	1	
E-3	18	HZY6-90001-000	BOLT, FLANGE, 8X55	2	
E-3	19	HZY6-90005-000	BOLT, FLANGE, 12X83	1	
E-3	20	HPNA-90006-003	BOLT-WASHER, 11X95	10	
E-3	21	HZW9-90011-000	BOLT, FLANGE, 6X14(CT200)	7	
E-3	22	HZW9-90016-000	BOLT, FLANGE, 6X25	18	
E-3	23	HZY3-90026-000	BOLT, FLANGE, 8X20	4	
E-3	24	HZY3-90054-000	BOLT, FLANGE, 8X35	10	
E-3	25	HZY6-90082-003	CAP, BOLT, 8MM	1	
E-3	26	HZW4-90156-000	BOLT, FLANGE, 8X50	4	
E-3	27	HZW4-90162-000	BOLT, FLANGE, 10X70	1	
E-3	28	HZY3-90204-000	NUT, FLANGE CAP, 10MM	2	
E-3	29	HPR4-90401-000	WASHER, SEALING, 28MM	1	

E-3

CYLINDER BLOCK

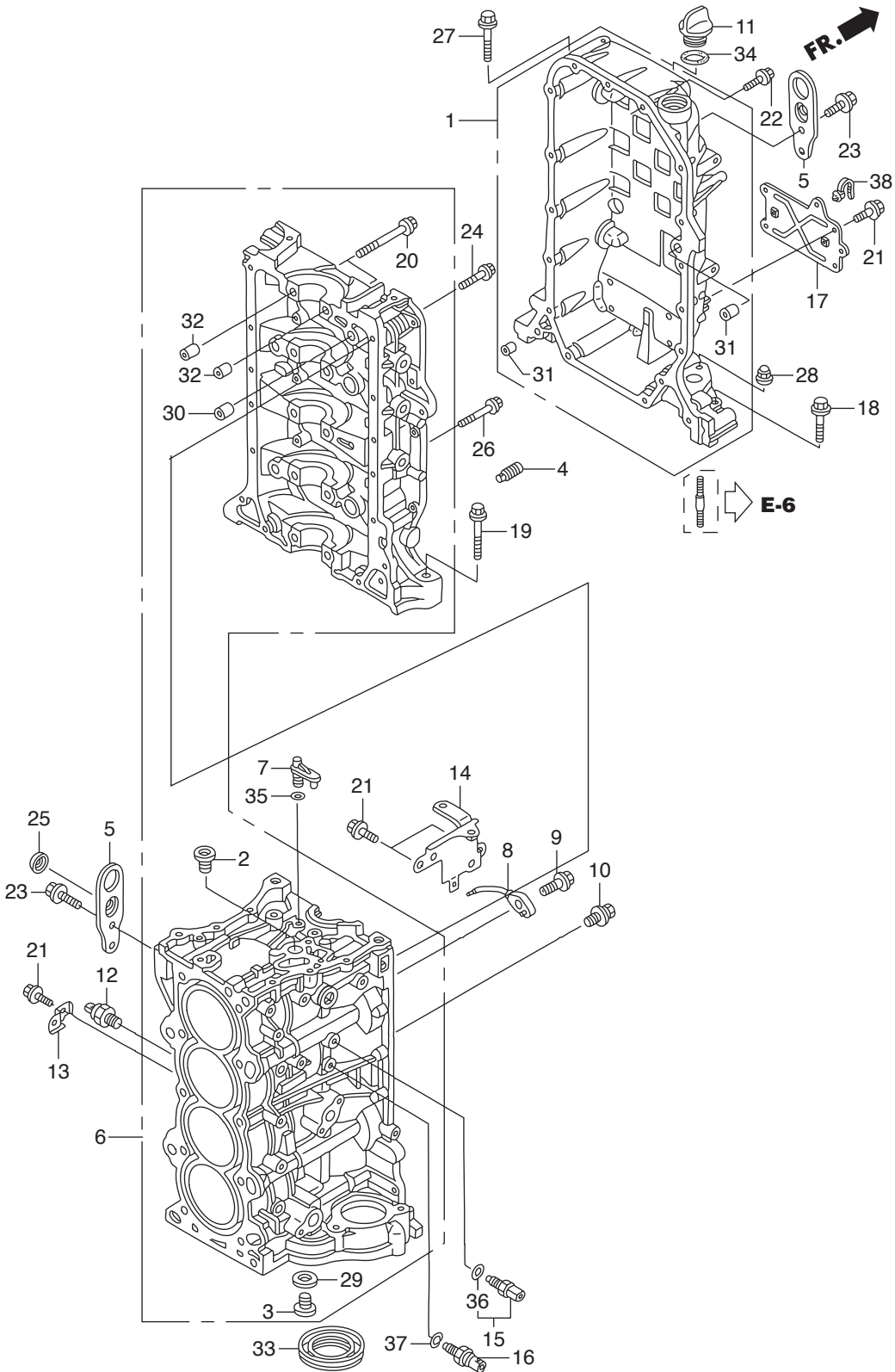



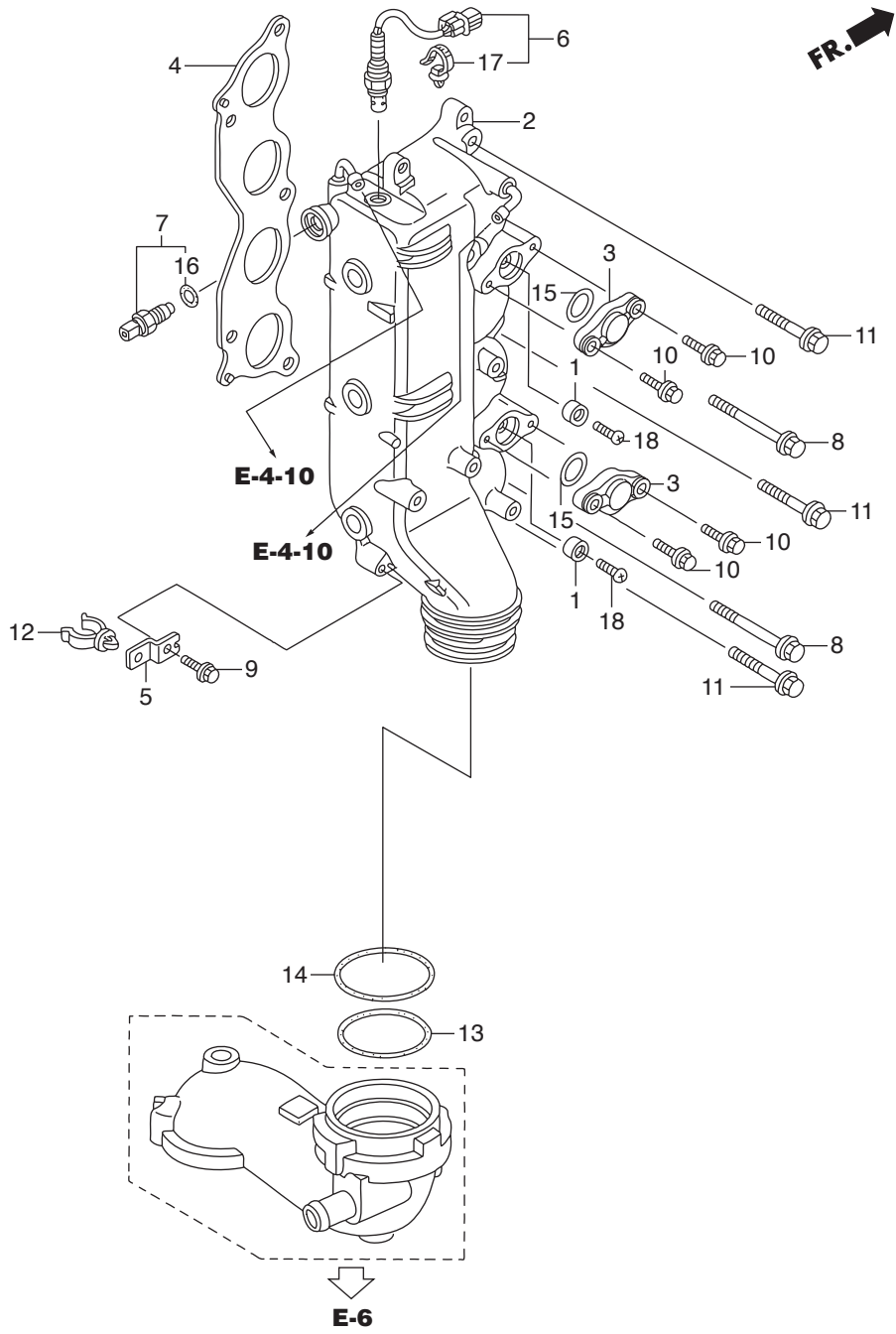



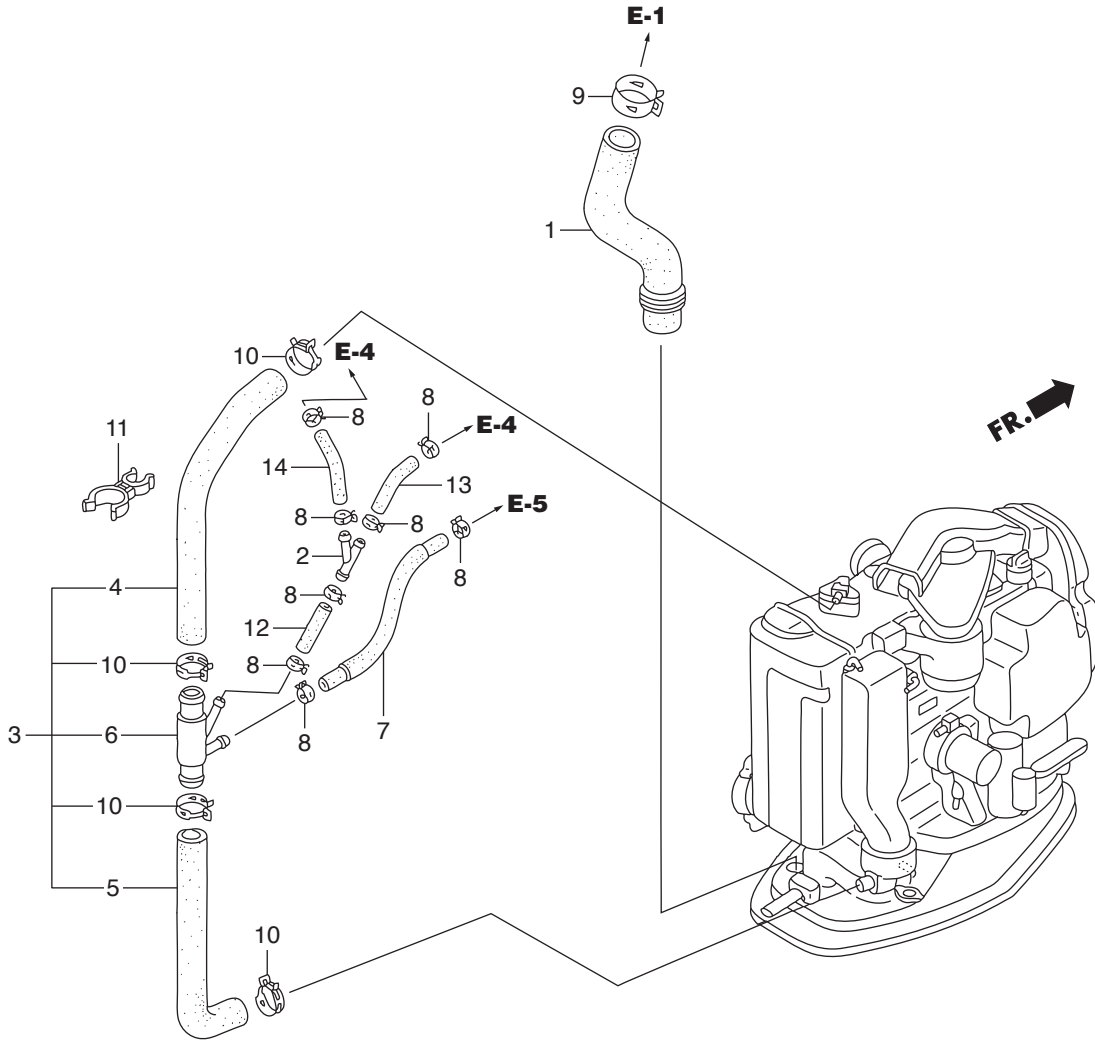





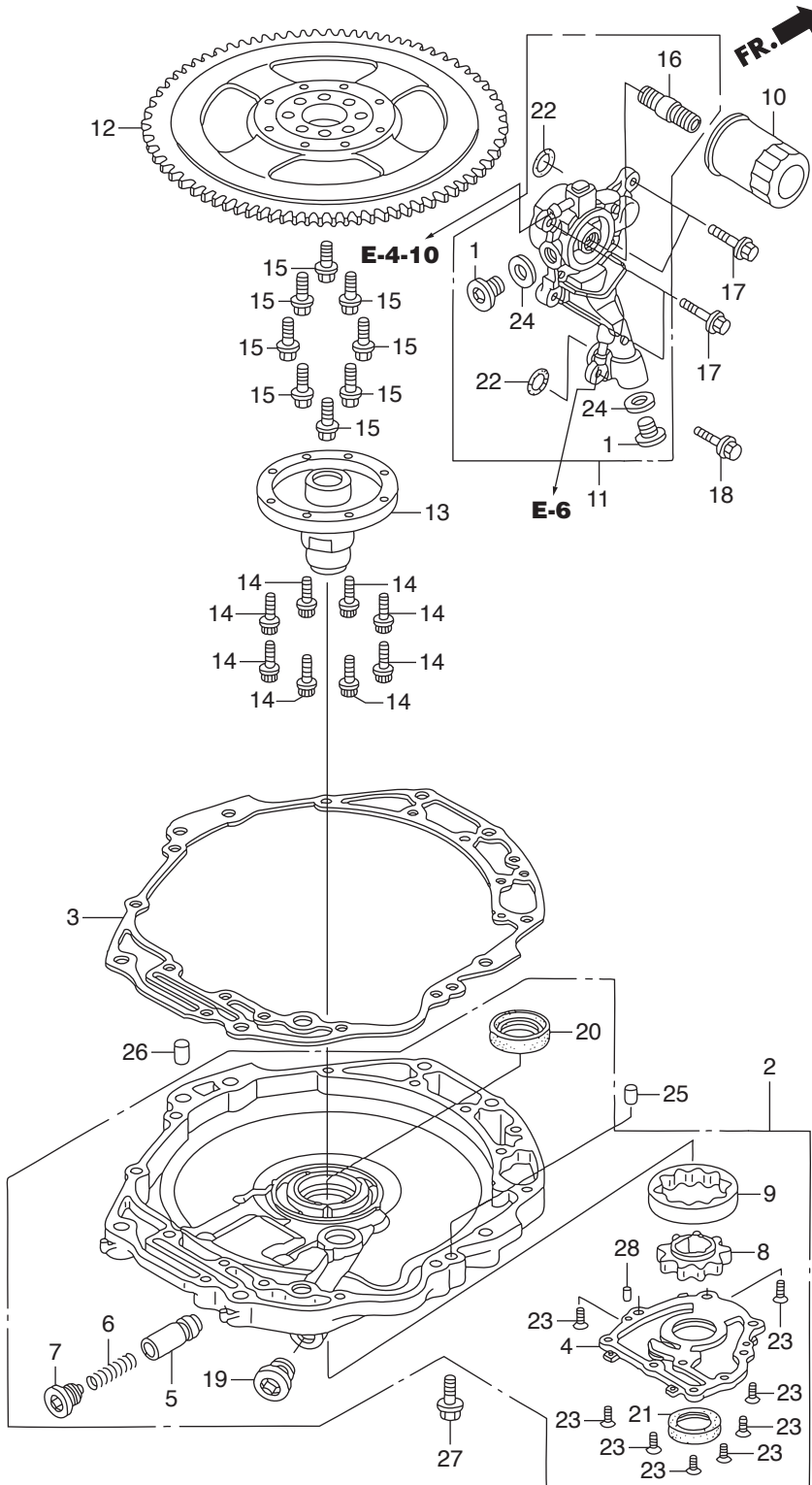

Ref.No.	Part No.	Description	Q' ty	Remarks	
			BFT150A		
E-5	1	HZW1-12217-010	BOLT, SEALING, 20MM	2	
E-5	2	HZY6-15100-000ZA	PUMP ASSY., OIL	1	*NH8* DARK GRAY
E-5	3	HZY6-15112-000	PACKING, OIL PUMP BODY	1	
E-5	4	HZY6-15121-000	COVER, OIL PUMP	1	
E-5	5	HPE0-15231-000	VALVE, RELIEF	1	
E-5	6	HPG6-15232-000	SPRING, RELIEF VALVE	1	
E-5	7	HPC6-15233-000	BOLT, SEALING, 18MM	1	
E-5	8	HZW5-15331-003	ROTOR, INNER OIL PUMP	1	
E-5	9	HZW5-15341-003	ROTOR, OUTER OIL PUMP	1	
E-5	10	HRTA-15400-004	CARTRIDGE, OIL FILTER	1	(TOYO ROKI)
E-5	11	HZY6-15410-010ZA	FLANGE COMP., OIL FILTER	1	*NH8* DARK GRAY
E-5	12	HZY6-31110-000ZA	FLYWHEEL COMP.	1	*TBLACK* BLACK
E-5	13	HZY3-31116-000	BOSS, FLYWHEEL	1	
E-5	14	HZW5-90002-013	BOLT, SPECIAL, 8MM	8	
E-5	15	HPH3-90011-000	BOLT, FLANGE, 12MM	8	
E-5	16	HPH1-90015-013	HOLDER, OIL FILTER	1	
E-5	17	HZW9-90016-000	BOLT, FLANGE, 6X25	4	
E-5	18	HZW5-90018-000	BOLT, FLANGE, 6X20	1	
E-5	19	HZV5-90081-010	BOLT, SEALING, 22MM	2	
E-5	20	HZW5-91201-003	OIL SEAL, 46X60X9	1	
E-5	21	HP01-91212-003	OIL SEAL, 31X46X7(NOK)	1	
E-5	22	HVD6-91360-003	O-RING, 22.5X2.4	2	
E-5	23	HCO-93600-06016-0A	SCREW, FLAT, 6X16	9	
E-5	24	HCO-94109-20000	WASHER, DRAIN PLUG, 20MM	2	
E-5	25	HCO-94301-10160	DOWEL PIN, 10X16	1	
E-5	26	HCO-94301-14200	DOWEL PIN, 14X20	1	
E-5	27	HCO-95701-08032-08	BOLT, FLANGE, 8X32	5	
E-5	28	HCO-96220-50080	ROLLER, 5X8	2	

# E-6 OIL PAN

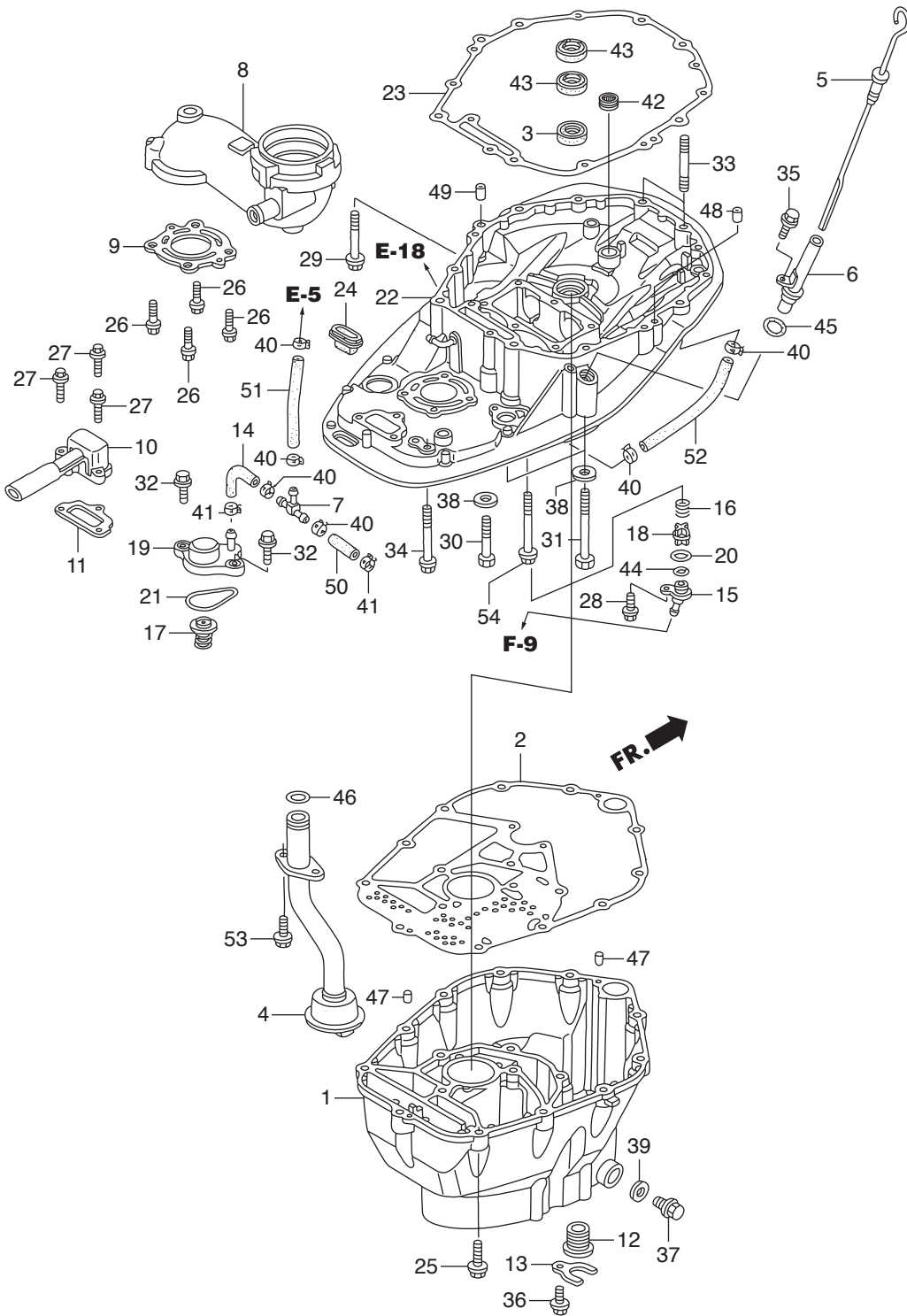

Ref.No.	Part No.	Description	Q' ty	Remarks	
			BFT150A		
E-6	1	HZY6-11321-010ZB	CASE, OIL	1	*TGRAY* GRAY
E-6	2	HZY6-11381-010	PACKING, OIL PAN	1	
E-6	3	HZW5-15113-000	RUBBER, OIL PUMP	1	
E-6	4	HZY6-15220-010	STRAINER COMP., OIL	1	
E-6	5	HZY6-15655-000	GAUGE COMP., OIL LEVEL	1	
E-6	6	HZW1-15665-020	PIPE COMP., OIL LEVEL	1	
E-6	7	HMN5-17195-000	T-JOINT	1	
E-6	8	HZY6-18130-000ZA	GUIDE COMP., EX.	1	*NH8* DARK GRAY
E-6	9	HZY6-18135-003	GASKET, EX. GUIDE	1	
E-6	10	HZY6-18211-000	PORT, IDLE EXHAUST	1	
E-6	11	HZY6-18212-000	GASKET, IDLE EX. PORT	1	
E-6	12	HZW1-19252-000	GROMMET, WATER TUBE	1	
E-6	13	HZY6-19254-000	PLATE, WATER TUBE	1	
E-6	14	HZY6-19256-000	TUBE, WATER RELIEF	1	
E-6	15	HZZ3-19277-000	COVER, FLUSH VALVE	1	
E-6	16	HZW9-19279-000	SPRING, FLUSH VALVE	1	
E-6	17	HZY6-19290-003	VALVE ASSY., RELIEF	1	
E-6	18	HZW9-19291-000	VALVE, FLASH	1	
E-6	19	HZY6-19295-000	COVER, RELIEF VALVE	1	
E-6	20	HZW9-19297-000	PACKING, FLASH VALVE	1	
E-6	21	HZW9-19317-000	O-RING, THERMOSTAT COVER	1	
E-6	22	HZY6-23170-000ZA	CASE COMP., MOUNT	1	*NH8* DARK GRAY
E-6	23	HZY6-23172-000	GASKET, MOUNT CASE	1	
E-6	24	HZY3-23173-010	RUBBER, MOUNT CASE SEAL	1	
E-6	25	HZY6-90002-000	BOLT, FLANGE, 10X40	16	
E-6	26	HZY6-90014-000	BOLT, FLANGE, 8X30	4	
E-6	27	HZW9-90016-000	BOLT, FLANGE, 6X25	3	
E-6	28	HZW9-90105-000	BOLT, FLANGE, 6X20	1	
E-6	29	HZY6-90017-000	BOLT, FLANGE, 10X80	1	

# E-6 OIL PAN

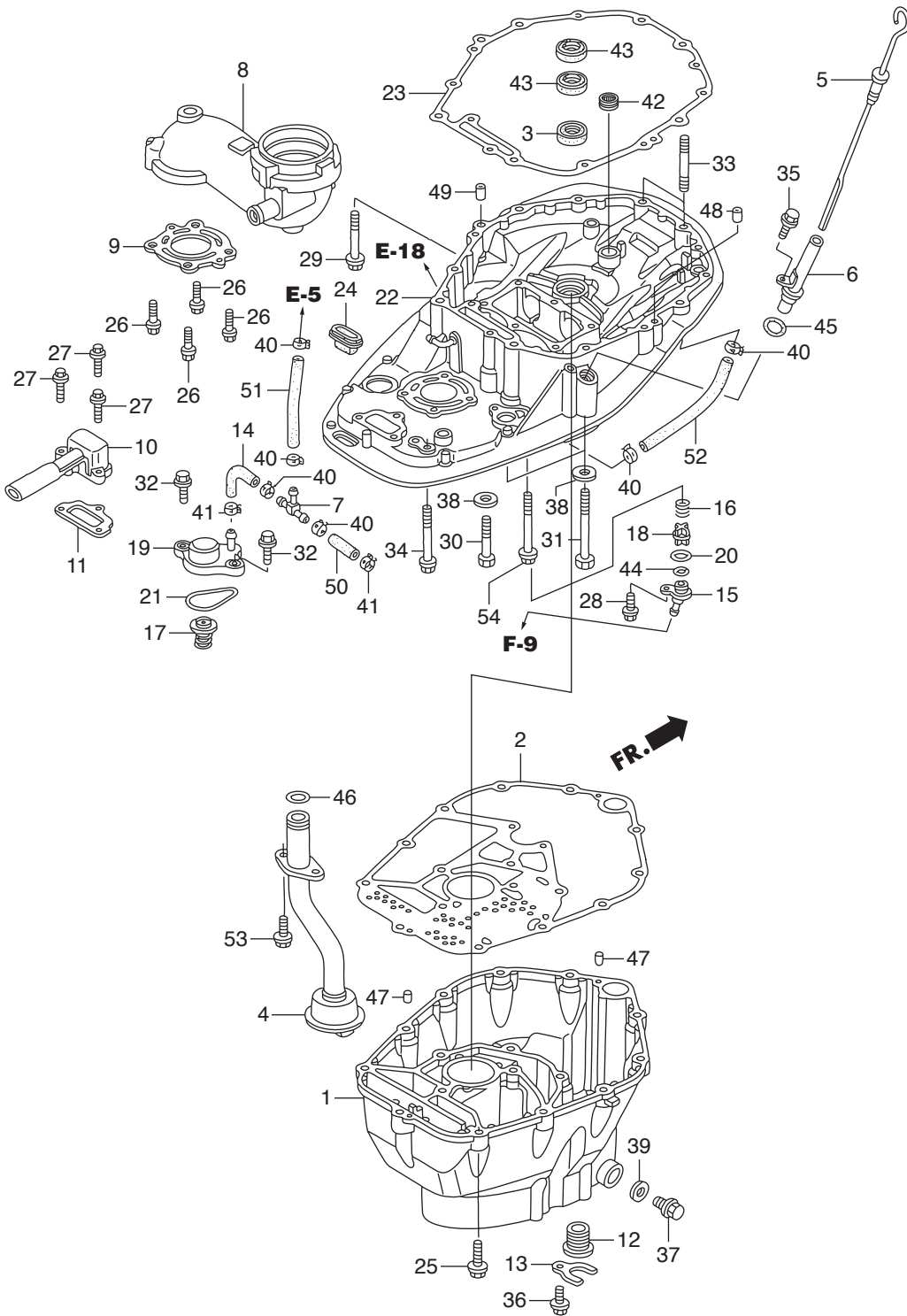

Ref.No.	Part No.	Description	Q' ty	Remarks	
			BFT150A		
E-6	30	HZY6-90018-000	BOLT, HEX., 12X70	1	
E-6	31	HZY6-90019-000	BOLT, HEX., 12X130	2	
E-6	32	HZY3-90030-000	BOLT, FLANGE, 6X22	2	
E-6	33	HZY6-90045-000	BOLT, STUD, 10X55	2	
E-6	34	HZY3-90046-000	BOLT, FLANGE, 8X100	1	
E-6	35	HZY3-90056-000	BOLT, FLANGE, 6X12	1	
E-6	36	HZW9-90102-000	BOLT, FLANGE, 6X12	1	
E-6	37	HZV5-90131-000	BOLT, DRAIN PLUG	1	
E-6	38	HZV5-90559-000	WASHER, PLAIN, 12MM	3	
E-6	39	HZE2-90601-000	WASHER, DRAIN PLUG, 12MM	1	
E-6	40	HZY3-90601-030	CLAMP, TUBE(D10.5)	6	
E-6	41	HZY6-90606-003	CLAMP, TUBE(D10.5)	2	
E-6	42	HZY3-91001-003	BEARING, NEEDLE, 20X28X13	1	(SOLID)
E-6	43	HZW5-91202-003	SEAL, WATER, 22X35X7	2	
E-6	44	H800-91303-000	O-RING, 16MM	1	
E-6	45	HPJ7-91309-010	O-RING, 11.5X3.5	1	
E-6	46	HPC6-91324-000	O-RING, 20.6X2.6	1	
E-6	47	HCO-94301-06100	DOWEL PIN, 6X10	2	
E-6	48	HCO-94301-10160	DOWEL PIN, 10X16	1	
E-6	49	HCO-94301-14200	DOWEL PIN, 14X20	1	
E-6	50	HCO-95005-70040-30	TUBE, 7X40	1	(HC-95005-70001-30M)
E-6	51	HCO-95005-70160-30	TUBE, 7X160	1	(HC-95005-70001-30M)
E-6	52	HCO-95005-70200-30	TUBE, 7X200	1	(HC-95005-70001-30M)
E-6	53	HCO-95701-06018-09	BOLT, FLANGE, 6X18	2	
E-6	54	HCO-95701-10110-09	BOLT, FLANGE, 10X110	2	

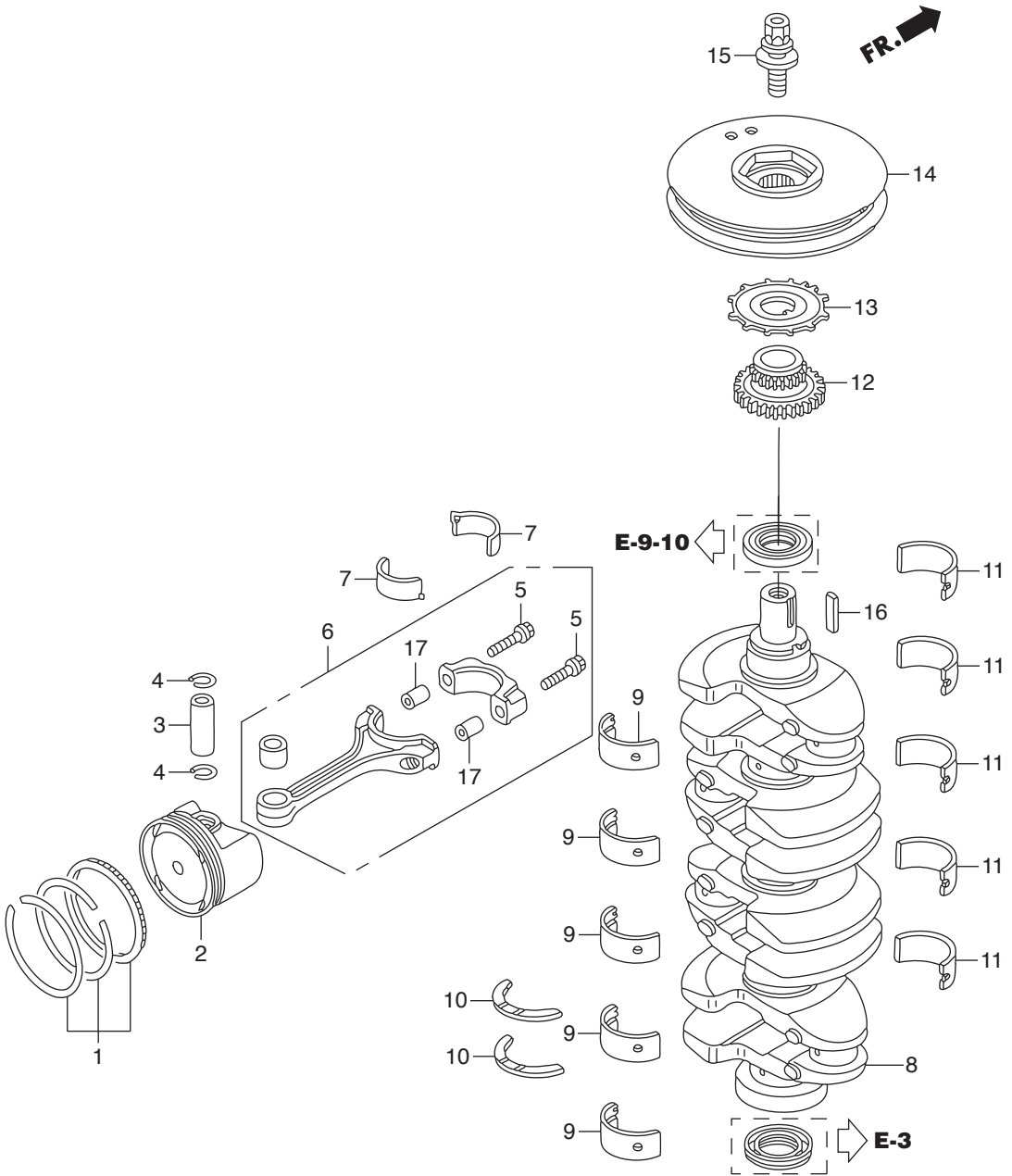



Ref.No.	Part No.	Description	Q' ty	Remarks	
			BFT150A		
E-7	1	HZY6-13010-000	RING SET, PISTON(STD.)	4	
E-7	2	HZY6-13101-000	PISTON A	4	
E-7		HZY6-13102-000	PISTON B	4	
E-7	3	HPNA-13111-010	PIN, PISTON	4	
E-7	4	HP5A-13115-000	CLIP, PISTON PIN	8	
E-7	5	HP8A-13204-A01	BOLT, CONNECTING ROD	8	
E-7	6	HPPA-13210-000	ROD COMP., CONNECTING	4	
E-7	7	HZY6-13211-004	BEARING A, CONNECTING ROD	8	(BLUE)
E-7		HZY6-13212-004	BEARING B, CONNECTING ROD	8	(BLACK)
E-7		HZY6-13213-004	BEARING C, CONNECTING ROD	8	(BROWN)
E-7		HZY6-13214-004	BEARING D, CONNECTING ROD	8	(GREEN)
E-7		HZY6-13215-004	BEARING E, CONNECTING ROD	8	(YELLOW)
E-7		HZY6-13216-004	BEARING F, CONNECTING ROD	8	(PINK)
E-7		HZY6-13217-004	BEARING G, CONNECTING ROD(RE D)	8	
E-7	8	HPPA-13310-000	CRANKSHAFT COMP.	1	
E-7	9	HPNA-13321-003	BEARING A, MAIN UPPER(BLUE)	5	(DAIDO)
E-7		HPNA-13322-003	BEARING B, MAIN UPPER(BLACK)	5	(DAIDO)
E-7		HPNA-13323-003	BEARING C, MAIN UPPER(BROWN)	5	(DAIDO)
E-7		HPNA-13324-003	BEARING D, MAIN UPPER(GREEN)	5	(DAIDO)
E-7		HPNA-13325-003	BEARING E, MAIN UPPER(YELLOW)	5	(DAIDO)
E-7		HPNA-13326-003	BEARING F, MAIN UPPER(PINK)	5	(DAIDO)
E-7	10	HZY6-13331-013	WASHER, THRUST	2	
E-7	11	HPNA-13341-003	BEARING A, MAIN LOWER(BLUE)	5	(DAIDO)
E-7		HPNA-13342-003	BEARING B, MAIN LOWER(BLACK)	5	(DAIDO)
E-7		HPNA-13343-003	BEARING C, MAIN LOWER(BROWN)	5	(DAIDO)
E-7		HPNA-13344-003	BEARING D, MAIN LOWER(GREEN)	5	(DAIDO)
E-7		HPNA-13345-003	BEARING E, MAIN LOWER(YELLOW)	5	(DAIDO)
E-7		HPNA-13346-003	BEARING F, MAIN LOWER(PINK)	5	(DAIDO)
E-7	12	HRAA-13620-A02	SPROCKET COMP., CHAIN DRIVE	1	

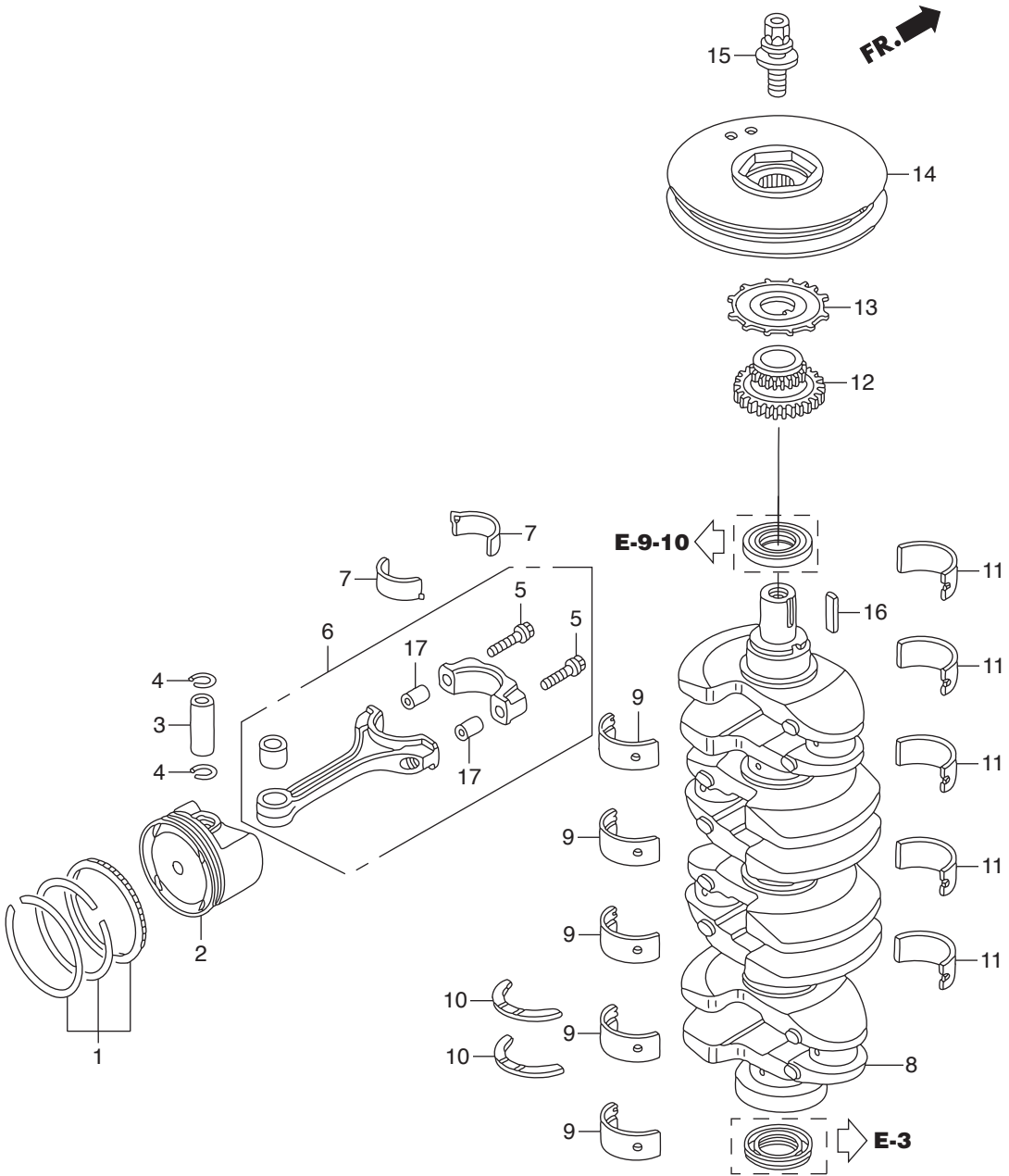



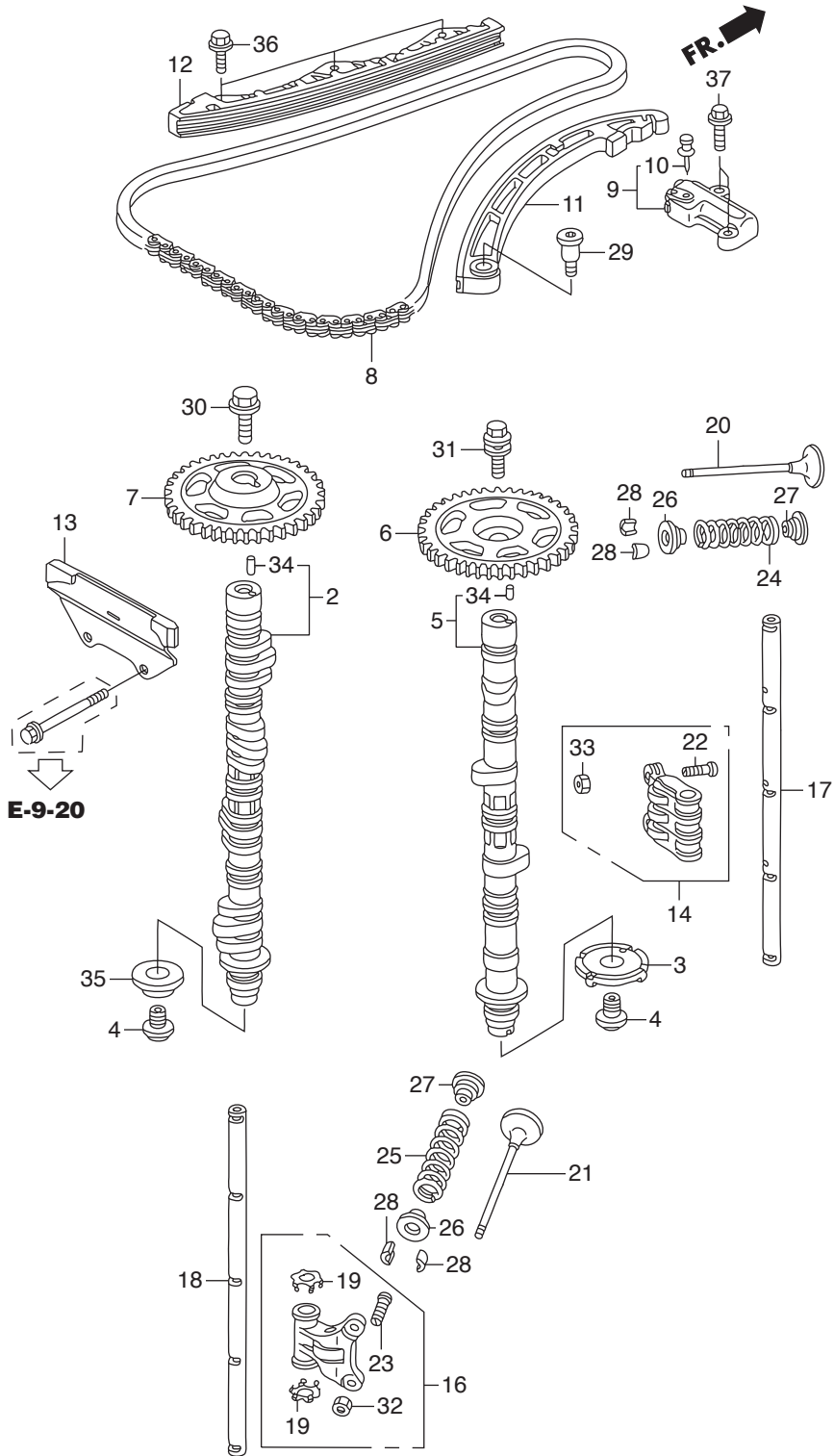

Ref.No.	Part No.	Description	Q' ty	Remarks	
			BFT150A		
E-9	2	HZY6-14110-000	CAMSHAFT COMP., IN.	1	
E-9	3	HPNA-14114-003	PLATE, TDC PULSE	1	
E-9	4	HPNA-14115-000	BOLT, SEALING, 14MM	2	
E-9	5	HZY6-14120-000	CAMSHAFT COMP., EX.	1	
E-9	6	HPNA-14210-000	SPROCKET, CAM CHAIN DRIVEN	1	(46T)
E-9	7	HZY6-14311-000	SPROCKET, CAM CHAIN DRIVEN IN.	1	(46T)
E-9	8	HR40-14401-A01	CHAIN(176L)(DAIDO)	1	
E-9	9	HZY6-14510-003	TENSIONER ASSY., CAM CHAIN	1	
E-9	10	HPNA-14511-003	STOPPER(TOOL)	1	
E-9	11	HPPA-14520-003	ARM COMP., CAM CHAIN TENSIONER	1	
E-9	12	HPPA-14530-003	GUIDE COMP., CAM CHAIN	1	
E-9	13	HRWC-14540-A02	GUIDE COMP. B, CAM CHAIN	1	
E-9	14	HPNA-14620-040	ARM ASSY., ROCKER	4	
E-9	16	HRAA-14624-A00	ARM ASSY., EX. ROCKER	4	
E-9	17	HPNA-14631-000	SHAFT, ROCKER	1	
E-9	18	HR40-14633-A00	SHAFT, EX. ROCKER	1	
E-9	19	HRAA-14647-A00	WASHER, THRUST	8	
E-9	20	HPNA-14711-000	VALVE, IN.	8	
E-9	21	HPRB-14721-A00	VALVE, EX.	8	
E-9	22	HPCX-14744-014	SCREW, TAPPET ADJUSTING	8	
E-9	23	HPNA-14744-004	SCREW, TAPPET ADJUSTING	8	
E-9	24	HZY6-14751-003	SPRING, IN. VALVE(PINK)	8	(NIPPON HATSUJO)
E-9	25	HPNA-14762-003	SPRING, EX. VALVE(GRAY)	8	(NIPPON HATSUJO)
E-9	26	HRAA-14765-A00	RETAINER, VALVE SPRING	16	
E-9	27	HPT0-14775-000	SEAT, VALVE SPRING	16	
E-9	28	HRGM-14781-A01	COTTER, VALVE(FUJI VALVE)	32	
E-9	29	HPNA-90003-000	BOLT, TENSIONER PIVOT	1	
E-9	30	HPNA-90032-000	BOLT, FLANGE, 12X47	1	
E-9	31	HPNA-90042-003	BOLT, FLANGE, 10X32	1	

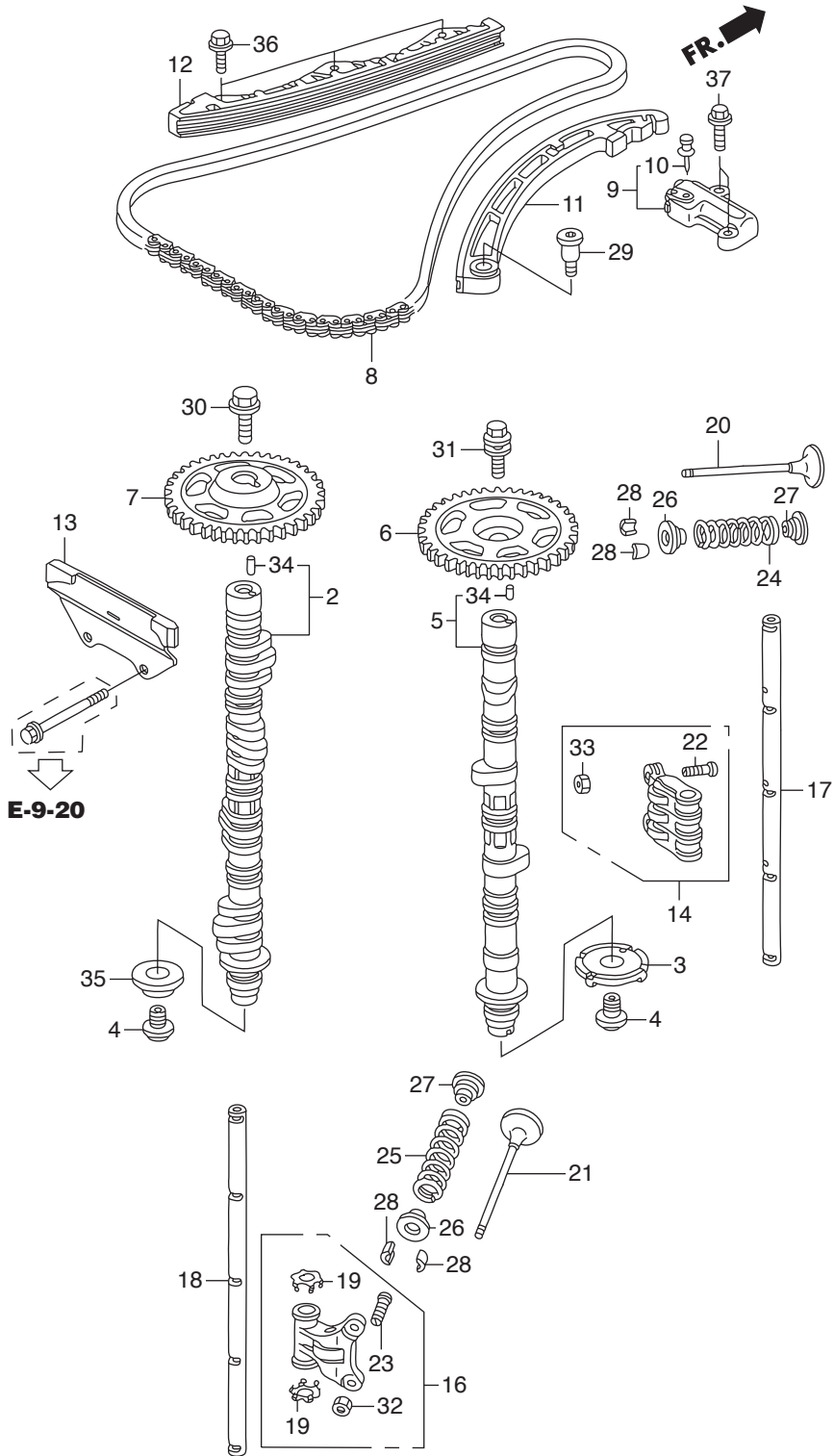



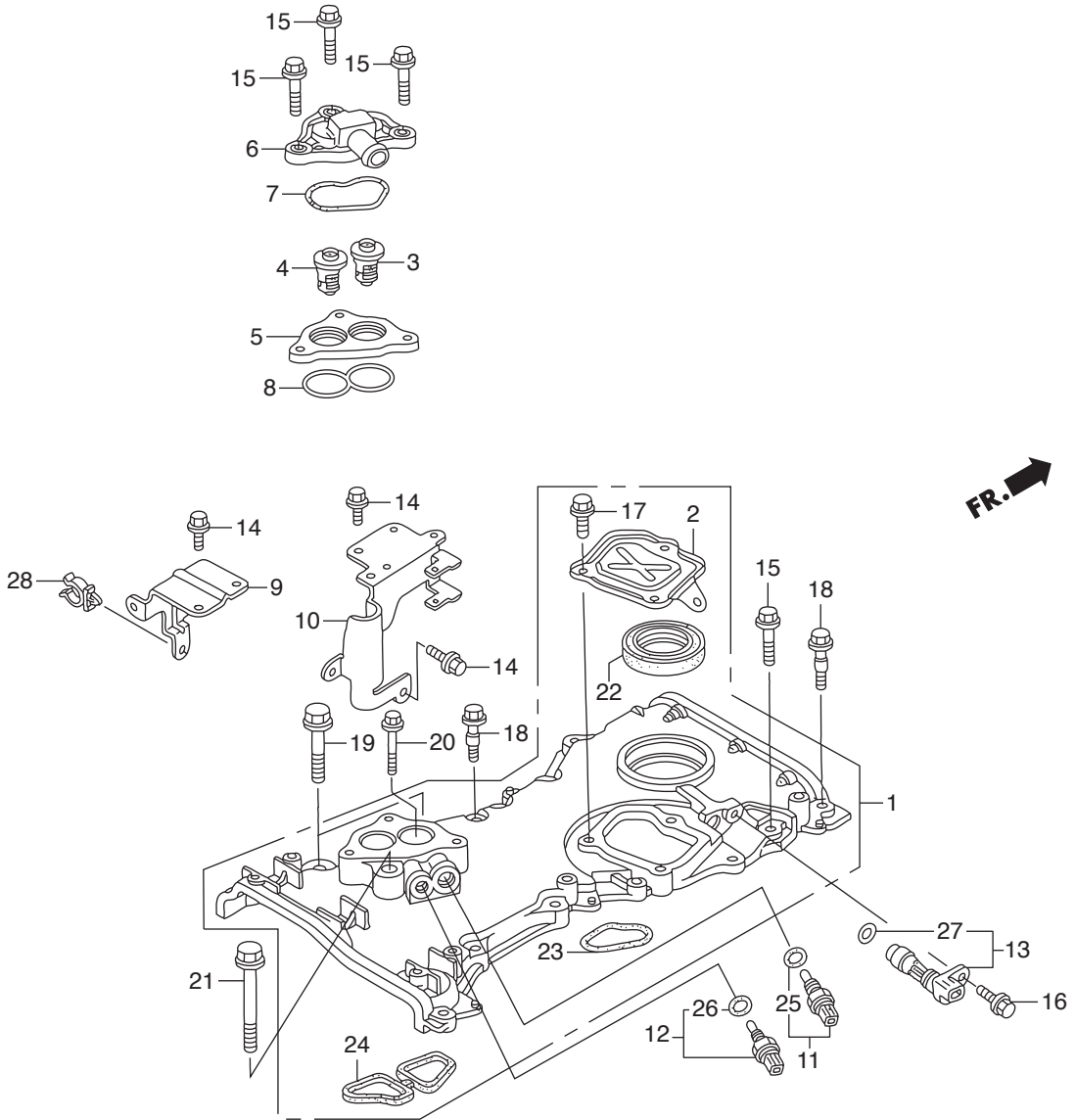



Ref.No.	Part No.	Description	Q' ty	Remarks	
			BFT150A		
E-9-10	1	HZY6-11410-425ZA	CASE ASSY., CHAIN	1	*NH8* DARK GRAY
E-9-10	2	HZY6-11412-000	COVER, CHAIN CASE	1	
E-9-10	3	HZY3-19300-023	THERMOSTAT ASSY.	1	
E-9-10	4	HZY6-19300-003	THERMOSTAT ASSY.	1	
E-9-10	5	HZY6-19313-000ZB	SPACER, THERMOSTAT COVER	1	*TGRAY* GRAY
E-9-10	6	HZY6-19315-010	COVER, THERMOSTAT	1	
E-9-10	7	HZY6-19318-010	PACKING, THERMOSTAT COVER	1	
E-9-10	8	HZY6-19319-000	PACKING, THERMOSTAT SPACER	1	
E-9-10	9	HZY6-32112-000	BRACKET B, HARNESS CLIP	1	
E-9-10	10	HZY6-32113-000	BRACKET C, HARNESS CLIP	1	
E-9-10	11	HZW5-35673-003	SENSOR ASSY., WATER	1	TEMPERATURE
E-9-10	12	HZY3-35673-003	SENSOR ASSY., WATER	1	TEMPERATURE
E-9-10	13	HPNB-37500-003	SENSOR ASSY., CRANK	1	
E-9-10	14	HZW9-90011-000	BOLT, FLANGE, 6X14(CT200)	5	
E-9-10	15	HZY3-90016-000	BOLT, FLANGE, 6X28	13	
E-9-10	16	HZY3-90017-000	BOLT, FLANGE, 6X16	1	
E-9-10	17	HZY3-90021-000	BOLT, FLANGE, 6X14	3	
E-9-10	18	HZY6-90023-000	BOLT, SPECIAL, 6X31	2	
E-9-10	19	HZY3-90040-000	BOLT, FLANGE, 10X43	2	
E-9-10	20	HZY6-90059-000	BOLT, FLANGE, 6X38	1	
E-9-10	21	HZW4-90162-000	BOLT, FLANGE, 10X70	1	
E-9-10	22	HPNC-91212-004	OIL SEAL, 43X58X7(ARAI)	1	
E-9-10	23	HPNA-91302-004	O-RING, CHAIN CASE	1	
E-9-10	24	HZY6-91304-010	PACKING, CHAIN CASE	1	
E-9-10	25	HPK2-91307-005	O-RING, 9.5X1.5(HONDA KIKAKI)	1	
E-9-10	26	HPNA-91307-003	O-RING, 9.5X1.9	1	
E-9-10	27	HPNA-91333-003	O-RING, 15X1.9	1	
E-9-10	28	HSP0-91546-A01	CLAMP, 18.5MM	1	

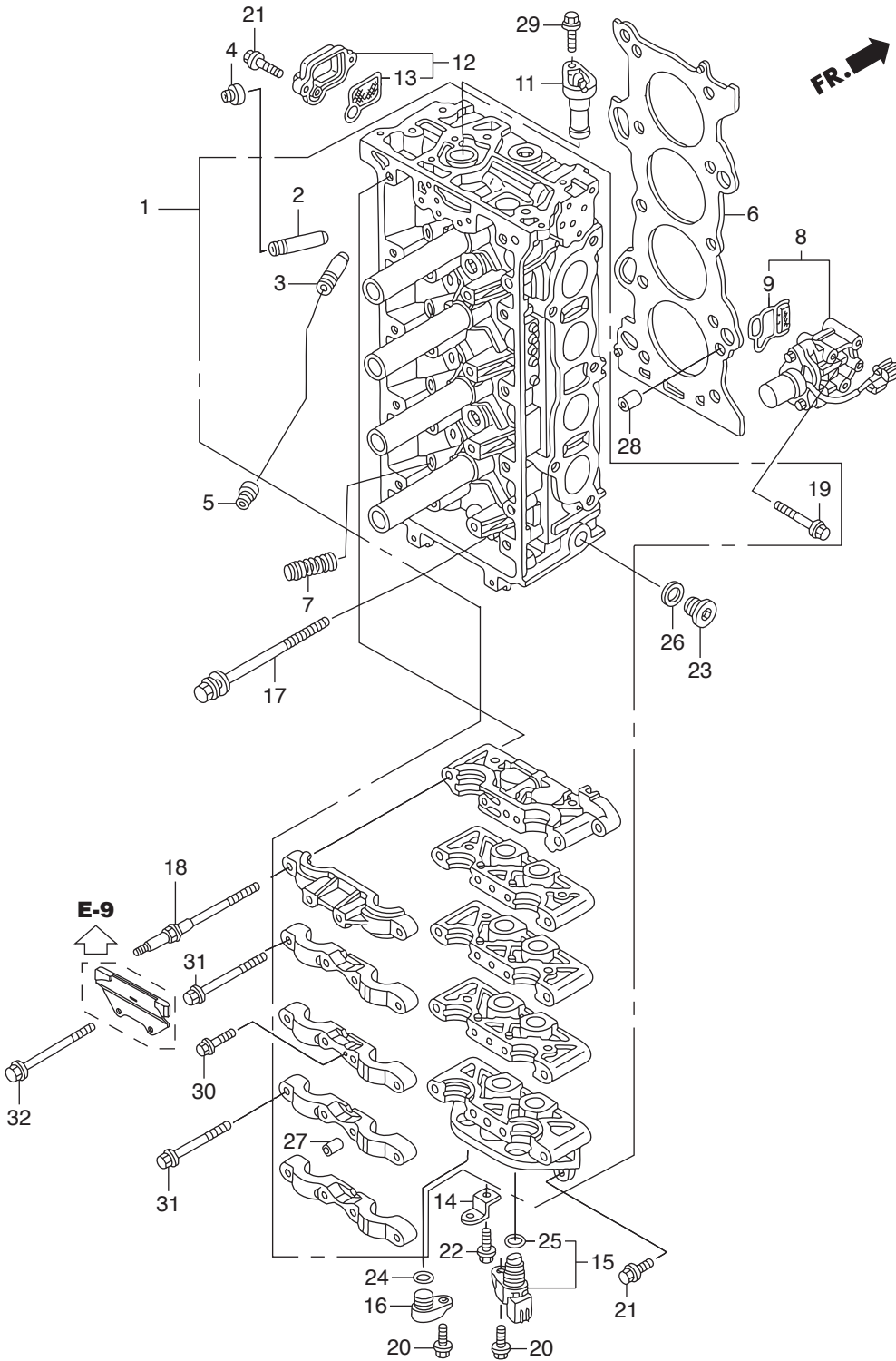

Ref.No.	Part No.	Description	Q' ty	Remarks	
			BFT150A		
E-9-20	1	HZY6-06122-010ZA	HEAD KIT, CYLINDER	1	*NH8* DARK GRAY
E-9-20	2	HPNA-12204-305	GUIDE, IN. VALVE(OS)	8	
E-9-20	3	HPNA-12205-305	GUIDE, EX. VALVE(OS)	8	
E-9-20	4	HPZ1-12210-003	SEAL A, VALVE STEM(ARAI)	8	
E-9-20		HPZ1-12210-004	SEAL A, VALVE STEM(NOK)	8	
E-9-20	5	HPZ1-12211-003	SEAL B, VALVE STEM(ARAI)	8	
E-9-20		HPZ1-12211-004	SEAL B, VALVE STEM(NOK)	8	
E-9-20	6	HZY6-12251-003	GASKET COMP., CYLINDER HEAD	1	
E-9-20	7	HPNA-14820-013	MOTION COMP., LOST	4	
E-9-20	8	HZY6-15810-013ZA	VALVE ASSY., SPOOL	1	*NH8* DARK GRAY
E-9-20	9	HRAA-15815-A02	FILTER ASSY., SPOOL VALVE	1	
E-9-20	11	HZY6-15834-000	PLUG, VTC HOLE	1	
E-9-20	12	HZY6-15840-000ZA	STRAINER ASSY., VTC	1	*NH8* DARK GRAY
E-9-20	13	HRAA-15845-A01	FILTER ASSY., VTC	1	
E-9-20	14	HZY6-32116-000	BRACKET F, CLIP	1	
E-9-20	15	HPNB-37510-003	SENSOR ASSY., TDC	1	
E-9-20	16	HZY6-37521-000	PLUG, TDC HOLE	1	
E-9-20	17	HPNA-90005-003	BOLT-WASHER, 11X155	10	
E-9-20	18	HPNA-90011-003	BOLT A, HEAD COVER	6	
E-9-20	19	HZY6-90011-000	BOLT, FLANGE, 6X52	3	
E-9-20	20	HZY3-90017-000	BOLT, FLANGE, 6X16	2	
E-9-20	21	HZW5-90018-000	BOLT, FLANGE, 6X20	4	
E-9-20	22	HZY3-90021-000	BOLT, FLANGE, 6X14	1	
E-9-20	23	HZY6-90048-010	BOLT, SEALING, 20MM	1	
E-9-20	24	HZY6-91303-003	O-RING, 15X1.9	1	
E-9-20	25	HPNA-91333-003	O-RING, 15X1.9	1	
E-9-20	26	HCO-94109-20000	WASHER, DRAIN PLUG, 20MM	1	
E-9-20	27	HCO-94301-10160	DOWEL PIN, 10X16	20	
E-9-20	28	HCO-94301-14200	DOWEL PIN, 14X20	2	

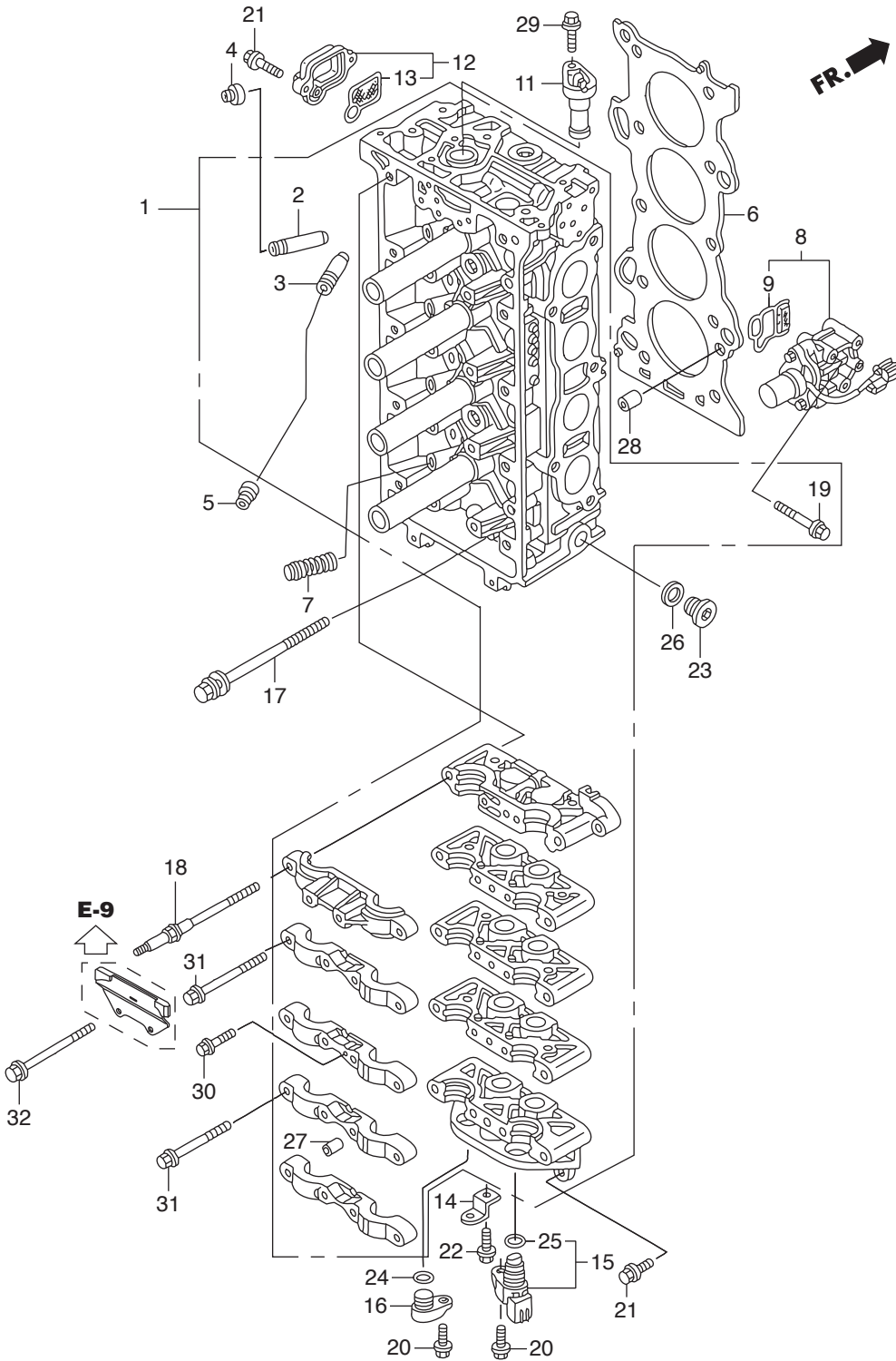







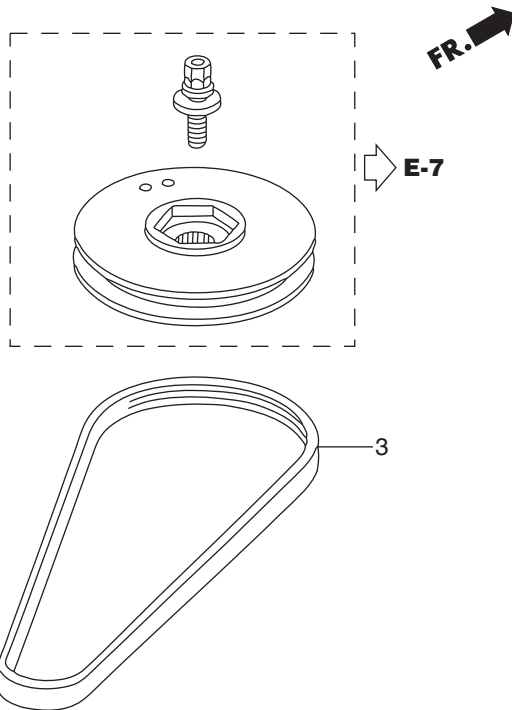
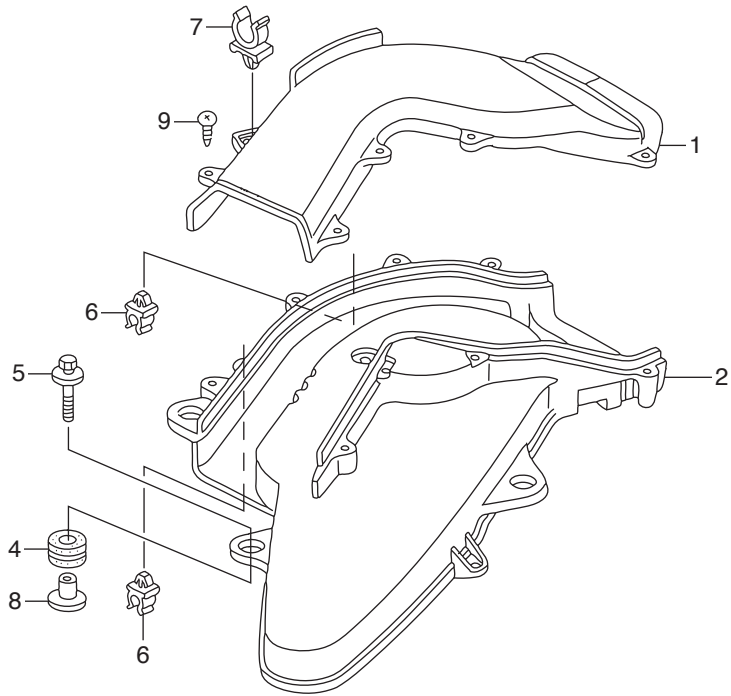





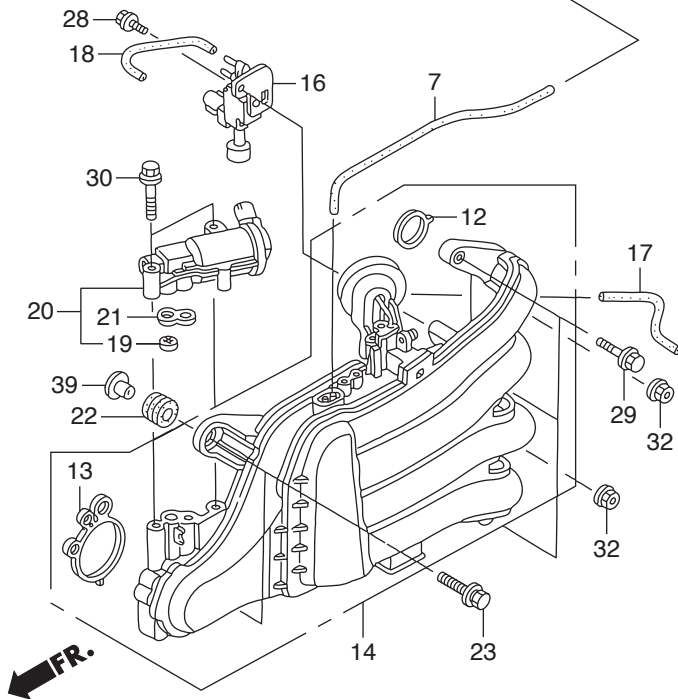
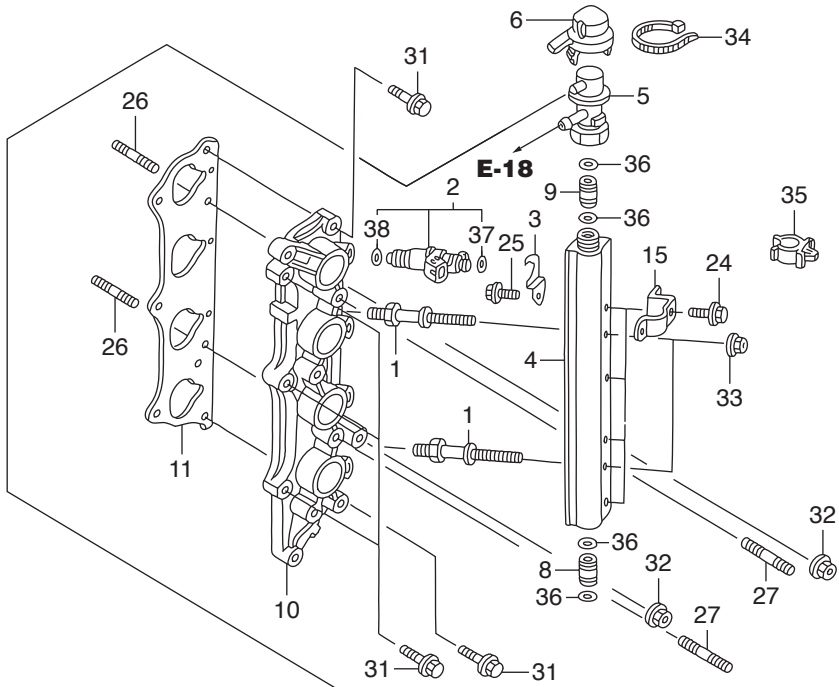

Ref.No.	Part No.	Description	Q' ty	Remarks	
			BFT150A		
E-14	1	HZY6-16089-000	BOLT, FUEL PIPE	2	
E-14	2	HZY6-16450-003	INJECTOR ASSY., FUEL	4	
E-14	3	HZY6-16451-000	CLIP, INJECTOR	4	
E-14	4	HZY6-16621-000	LINE, FUEL	1	
E-14	5	HZY6-16740-003	REGULATOR ASSY., PRESSURE	1	
E-14	6	HZY6-16744-010	CAP, REGULATOR	1	
E-14	7	HZY6-16748-000	TUBE, PRESSURE REGULATOR	1	CONTROL
E-14	8	HZY3-16752-000	JOINT, FUEL PIPE	1	
E-14	9	HZY6-16752-000	JOINT, FUEL PIPE	1	
E-14	10	HZY6-17051-000ZA	BASE, INJECTOR	1	*NH8* DARK GRAY
E-14	11	HPNA-17055-004	GASKET A, INJECTOR BASE	1	
E-14	12	HZY6-17105-000	PACKING, INTAKE MANIFOLD	4	
E-14	13	HZY6-17109-000	PACKING, THROTTLE BODY	1	
E-14	14	HZY6-17110-003	MANIFOLD COMP., INTAKE	1	
E-14	15	HZY6-32111-000	BRACKET A, HARNESS CLIP	4	
E-14	16	HZY3-36163-003	VALVE ASSY., AIR BYPASS	1	
E-14	17	HZY6-36364-000	TUBE, DIAPHRAGM	1	
E-14	18	HZY6-36366-000	TUBE, BYPASS SOLENOID	1	
E-14	19	HPS4-36454-003	FILTER COMP., ELECTRONIC AIR	1	CONTROL VALVE(TOYO ROKI)
E-14	20	HZY6-36550-003	VALVE ASSY., ELECTRONIC AIR	1	CONTROL
E-14	21	HZY6-36551-003	PACKING, ELECTRONIC AIR	1	CONTROL VALVE
E-14	22	H121-51640-730	RUBBER, FR. CARRIER CUSHION	2	
E-14	23	HZW1-90014-000	BOLT-WASHER, 8X35	2	
E-14	24	HZY3-90021-000	BOLT, FLANGE, 6X14	4	
E-14	25	HZY3-90042-000	BOLT, FLANGE, 6X10	4	
E-14	26	HZY6-90043-000	BOLT, STUD 2, 8X25	2	
E-14	27	HZY6-90047-000	BOLT, STUD, 8X32	2	
E-14	28	HZY6-90049-000	BOLT, FLANGE, 5X12	1	
E-14	29	HZY3-90054-000	BOLT, FLANGE, 8X35	3	

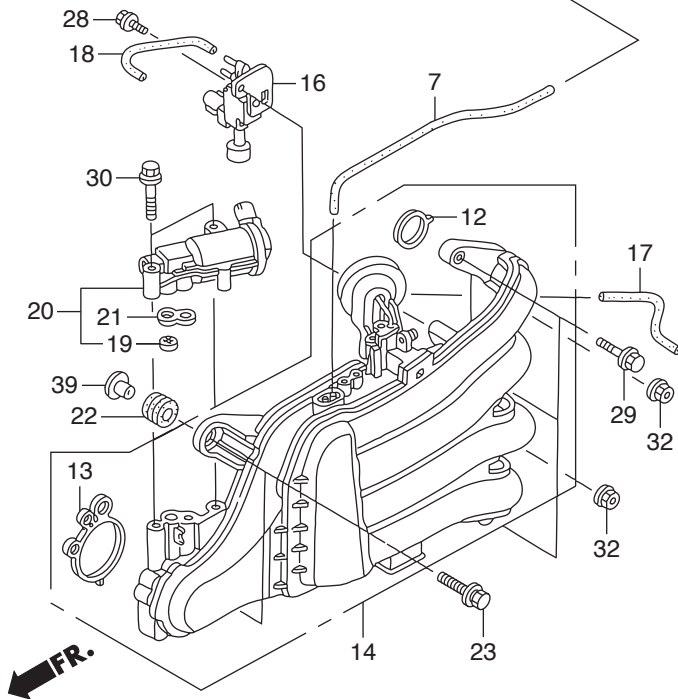
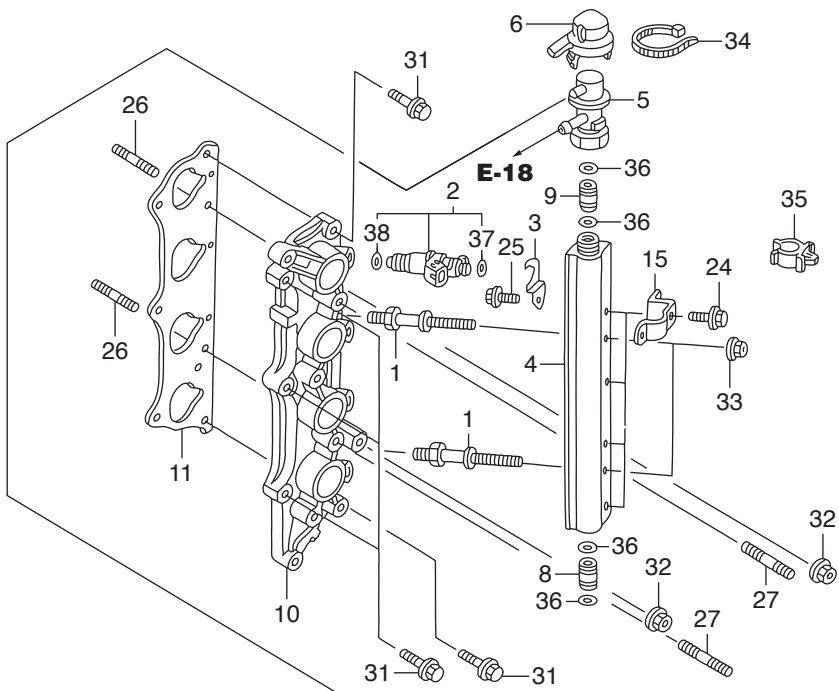



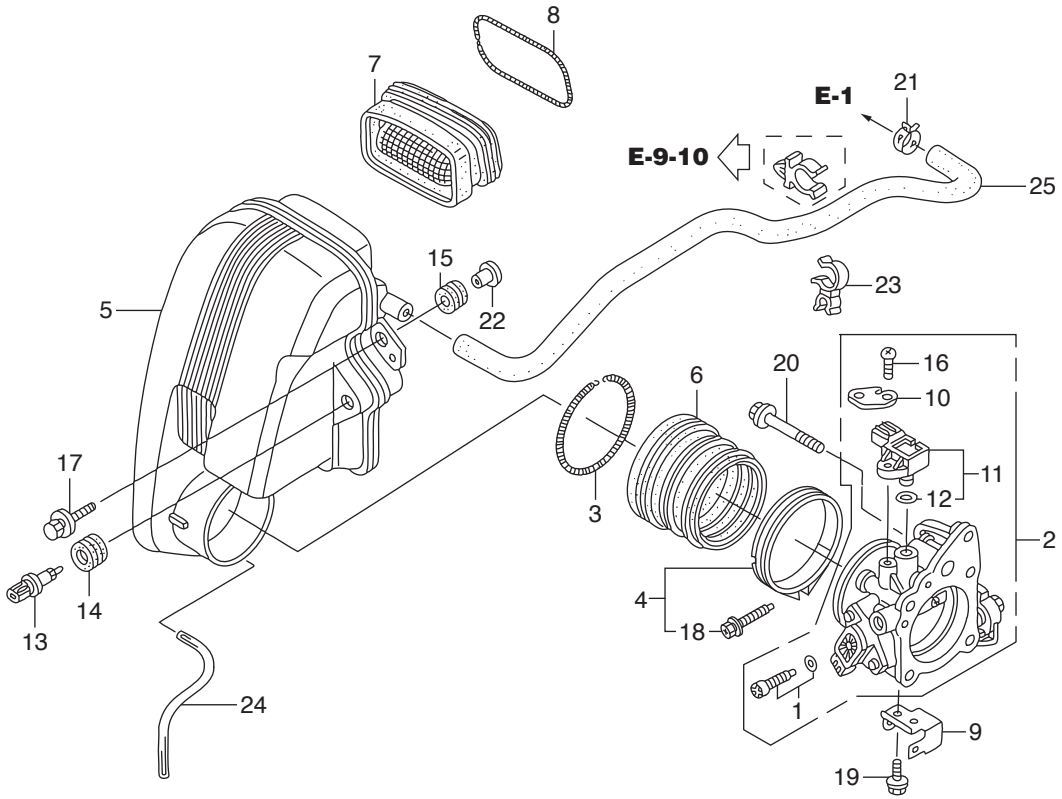

FR.

Ref.No.	Part No.	Description	Q' ty	Remarks	
			BFT150A		
E-15	1	HZY6-16016-003	SCREW SET	1	
E-15	2	HZY6-16400-013	THROTTLE BODY ASSY.	1	
E-15	3	HPY3-17249-000	SPRING, AIR FLOW TUBE	1	
E-15	4	HZY9-17315-000	BAND, AIR FLOW	1	
E-15	5	HZY6-17371-020	CASE COMP., SILENCER	1	
E-15	6	HZY6-17374-000	GROMMET, SILENCER	1	
E-15	7	HZY6-17397-013	GROMMET, SILENCER DUCT	1	
E-15	8	HZY6-17398-000	SPRING, SILENCER DUCT GROMMET	1	
E-15	9	HZY6-32115-000	BRACKET E, HARNESS CLIP	1	
E-15	10	HZY3-32128-000	BRACKET, SENSOR CORD	1	
E-15	11	HRNA-37830-A01	SENSOR ASSY., MAP	1	
E-15	12	HPGK-37835-A01	O-RING	1	
E-15	13	HPLC-37880-004	SENSOR ASSY., AIR TEMP	1	(MATSUSHITA DENSHI)
E-15	14	HP2A-37881-000	GROMMET, TA SENSOR	1	
E-15	15	HZV5-40102-000	GROMMET, UNDER CASE	3	
E-15	16	HZY6-90006-000	SCREW, PAN, 5X18	1	
E-15	17	HZW1-90013-000	BOLT-WASHER, 6X25	3	
E-15	18	HZY9-90017-000	BOLT-WASHER, 5X30	1	
E-15	19	HZY3-90056-000	BOLT, FLANGE, 6X12	1	
E-15	20	HZV1-90127-010	BOLT, FLANGE, 8X60	4	
E-15	21	HZV3-90601-030	CLAMP, TUBE(D17)	1	
E-15	22	HZV5-91553-010	COLLAR, C.D.I. UNIT CASE	3	
E-15	23	HSF1-91595-003	CLAMP, FUEL HOSE	1	
E-15	24	HCO-95003-07016-31	TUBE, VINYL, 4X7X160	1	(HC-95003-07001-60M)
E-15	25	HCO-95005-12740-20	TUBE, 12X740	1	(HC-95005-12001-20M)

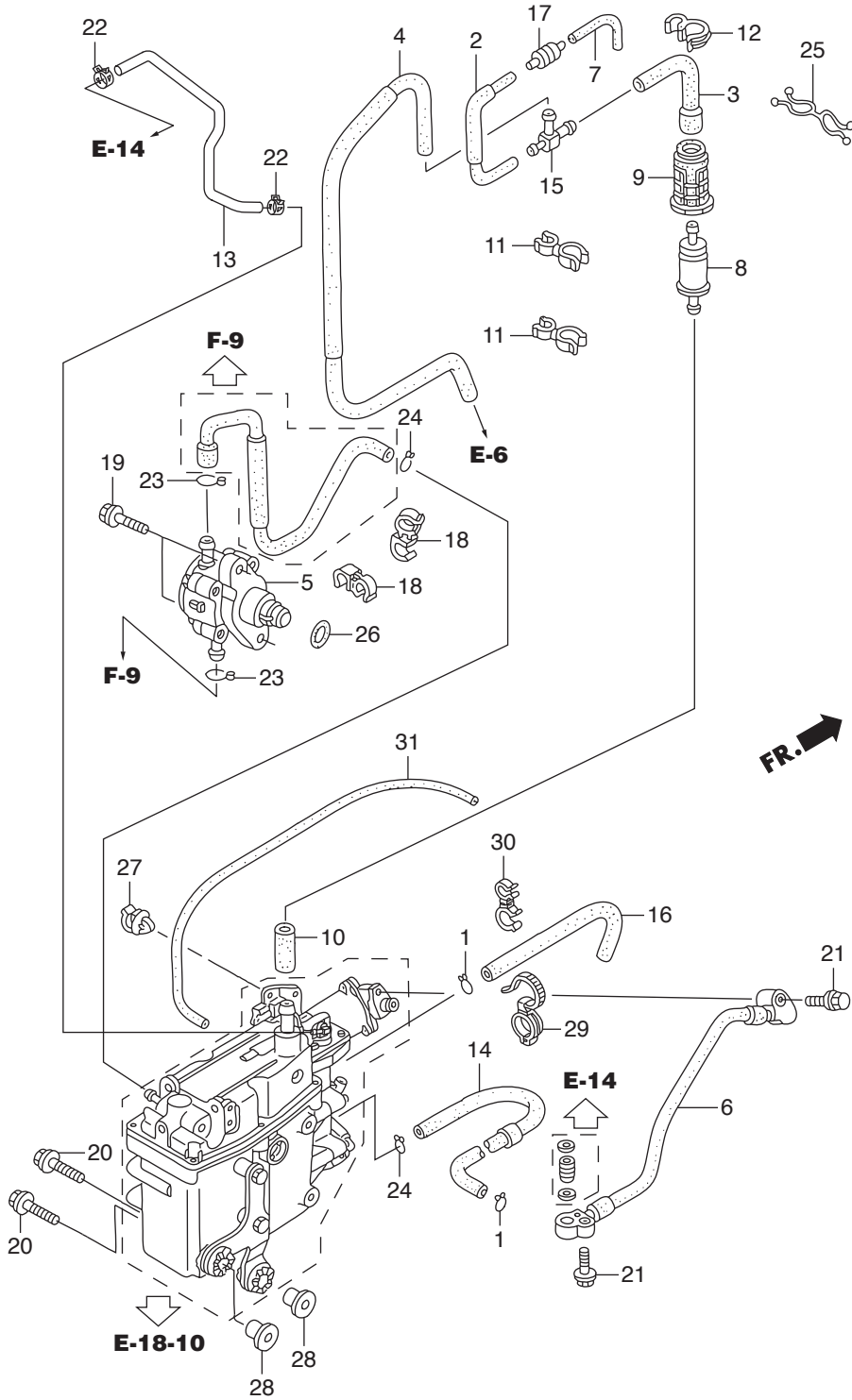



Ref.No.	Part No.	Description	Q' ty	Remarks	
			BFT150A		
E-18	1	HGHB-16163-610	CLIP, TUBE	2	
E-18	2	HZY6-16196-000	TUBE COMP. C, AIR VENT	1	
E-18	3	HZY6-16198-000	TUBE B, AIR VENT	1	
E-18	4	HZY6-16199-000	TUBE COMP., AIR VENT	1	
E-18	5	HZY6-16700-013	PUMP ASSY., FUEL	1	
E-18	6	HZY6-16755-003	HOSE COMP., FUEL	1	
E-18	7	HZV5-16881-000	TUBE D, FUEL	1	
E-18	8	H759-16911-003	STRAINER, FUEL PUMP	1	
E-18	9	HZW5-16915-000	SUSPENSION, STRAINER	1	
E-18	10	HMZ5-16952-000	TUBE B, FUEL	1	
E-18	11	HVM0-16965-771	CLAMP, HOSE	2	
E-18	12	HKV7-17368-671	CLAMP, PIPE	1	
E-18	13	HZY6-17723-020	HOSE, PRESSURE REGULATOR	1	RETURN
E-18	14	HZY6-19267-010	TUBE F, WATER	1	
E-18	15	HZY6-19269-000	T-JOINT	1	
E-18	16	HZY6-19273-000	TUBE G, WATER	1	
E-18	17	HZY6-36135-003	VALVE, CHECK	1	
E-18	18	HSE0-53740-953	CLIP, SENSOR HOSE	2	
E-18	19	HZY6-90010-000	BOLT, FLANGE, 6X27	2	
E-18	20	HZW1-90014-000	BOLT-WASHER, 8X35	2	
E-18	21	HZW9-90016-000	BOLT, FLANGE, 6X25	2	
E-18	22	HZW5-90601-030	CLAMP, TUBE(D10.7)	2	
E-18	23	HZY6-90601-000	CLIP, TUBE(B1 14.5)	2	
E-18	24	HZV0-90604-000	CLIP, TUBE(B12)	2	
E-18	25	HZY6-90605-003	CLIP, FUEL HOSE	1	
E-18	26	HPA9-91317-003	O-RING, 33.2X2.4(NOK)	1	
E-18	27	HSE0-91547-003	CLIP, HARNESS	1	
E-18	28	HZW1-91554-000	COLLAR, 8.5X14.5	2	
E-18	29	HSM4-91558-003	CLIP, TUBE(BLACK)(135MM)	1	





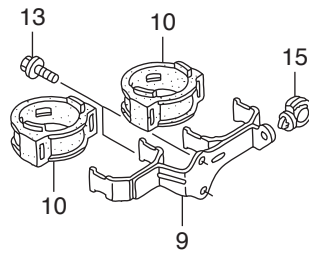
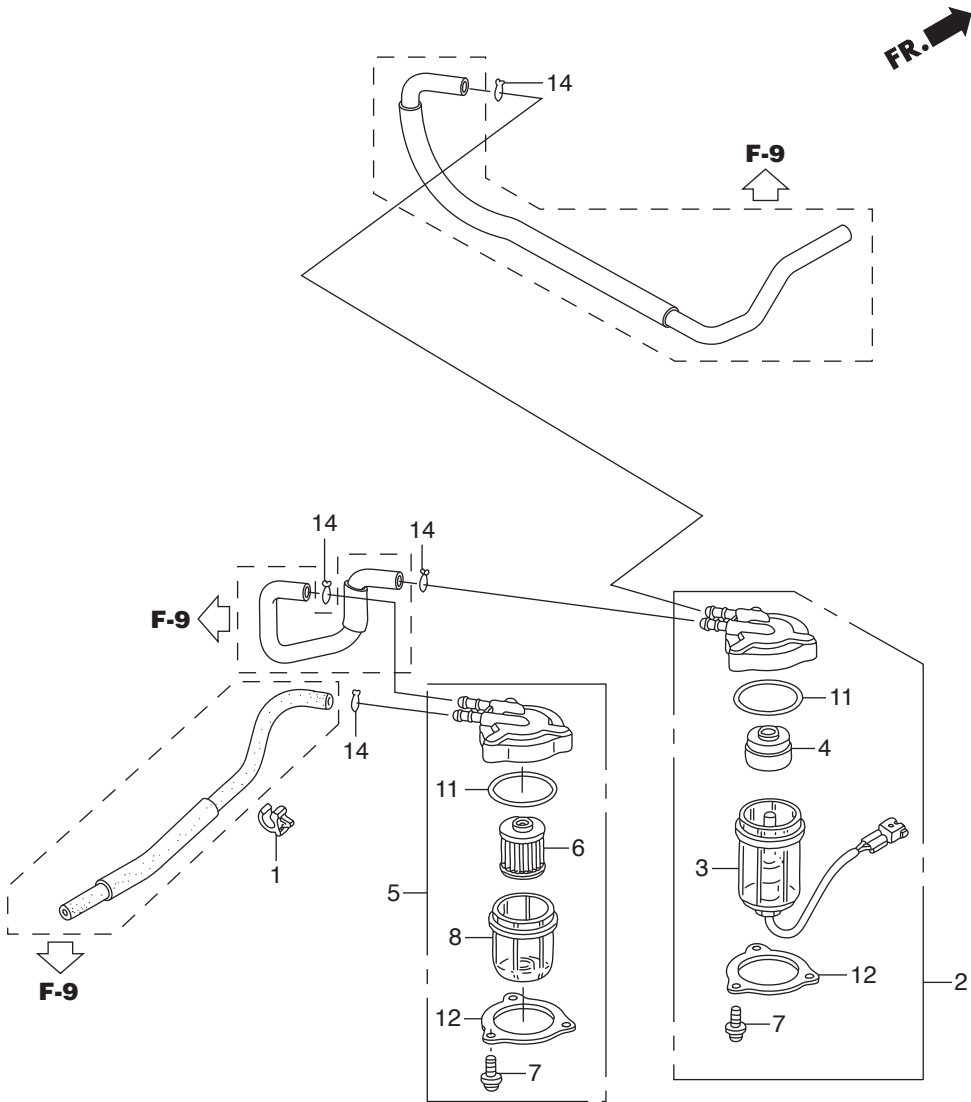



FR. 

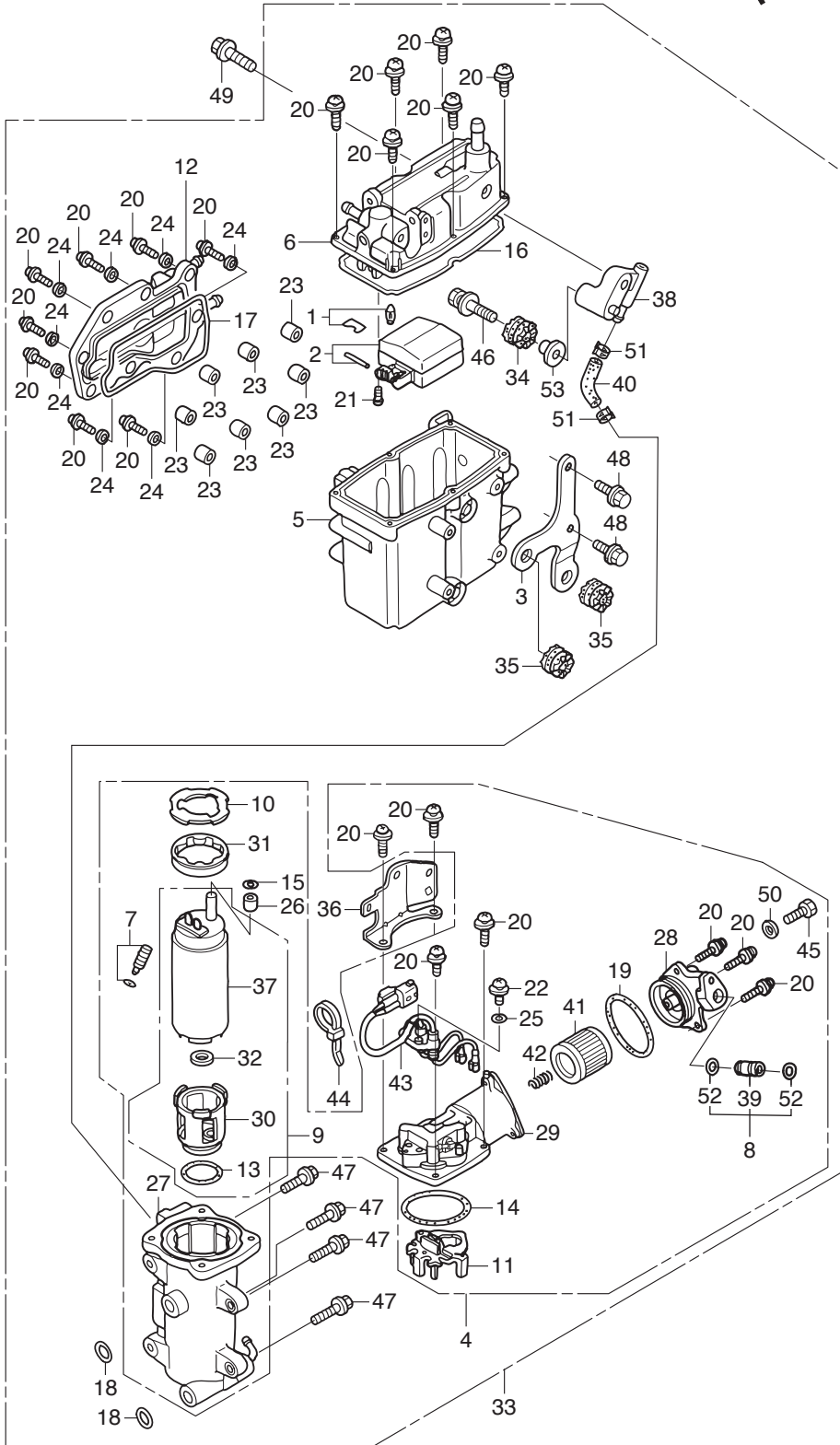

Ref.No.	Part No.	Description	Q' ty	Remarks	
			BFT150A		
E-18-10	1	HZY3-16011-000	VALVE SET, FLOAT	1	
E-18-10	2	HZY3-16013-000	FLOAT SET	1	
E-18-10	3	HZY6-16014-003	STAY A, PLATE	1	
E-18-10	4	HZY6-16017-043	PUMP UNIT, FUEL	1	
E-18-10	5	HZY6-16019-003	BODY COMP., CHAMBER	1	
E-18-10	6	HZY6-16020-023	COVER COMP.	1	
E-18-10	7	HZY3-16024-000	SCREW SET, DRAIN	1	
E-18-10	8	HZY3-16026-000	JOINT SET	1	
E-18-10	9	HZY6-16036-003	PUMP UNIT, FUEL(B)	1	
E-18-10	10	HZY3-16041-000	PLATE	1	
E-18-10	11	HZY3-16042-000	HOLDER	1	
E-18-10	12	HZY3-16061-000	COVER, WATER JACKET	1	
E-18-10	13	HZY3-16072-000	O-RING	1	
E-18-10	14	HZY3-16073-000	O-RING	1	
E-18-10	15	HZY3-16074-000	O-RING	1	
E-18-10	16	HZY3-16075-000	O-RING	1	
E-18-10	17	HZY3-16076-000	O-RING	1	
E-18-10	18	HZY3-16077-000	O-RING	2	
E-18-10	19	HZY3-16078-000	O-RING	1	
E-18-10	20	HZW5-16081-010	SCREW-WASHER	21	
E-18-10	21	HZY3-16082-000	SCREW, PAN	2	
E-18-10	22	HZY3-16083-000	SCREW, WASHER	1	
E-18-10	23	HZW5-16086-000	COLLAR	8	
E-18-10	24	HZW5-16087-000	WASHER, PLAIN	8	
E-18-10	25	HZY3-16087-000	WASHER, PLAIN	1	
E-18-10	26	HZY3-16088-000	COLLAR	1	
E-18-10	27	HZY6-16701-003	CASE COMP., PUMP	1	
E-18-10	28	HZW5-16708-003	COVER, PUMP(B)	1	
E-18-10	29	HZW5-16715-023	COVER, PUMP(A)	1	

FR. 

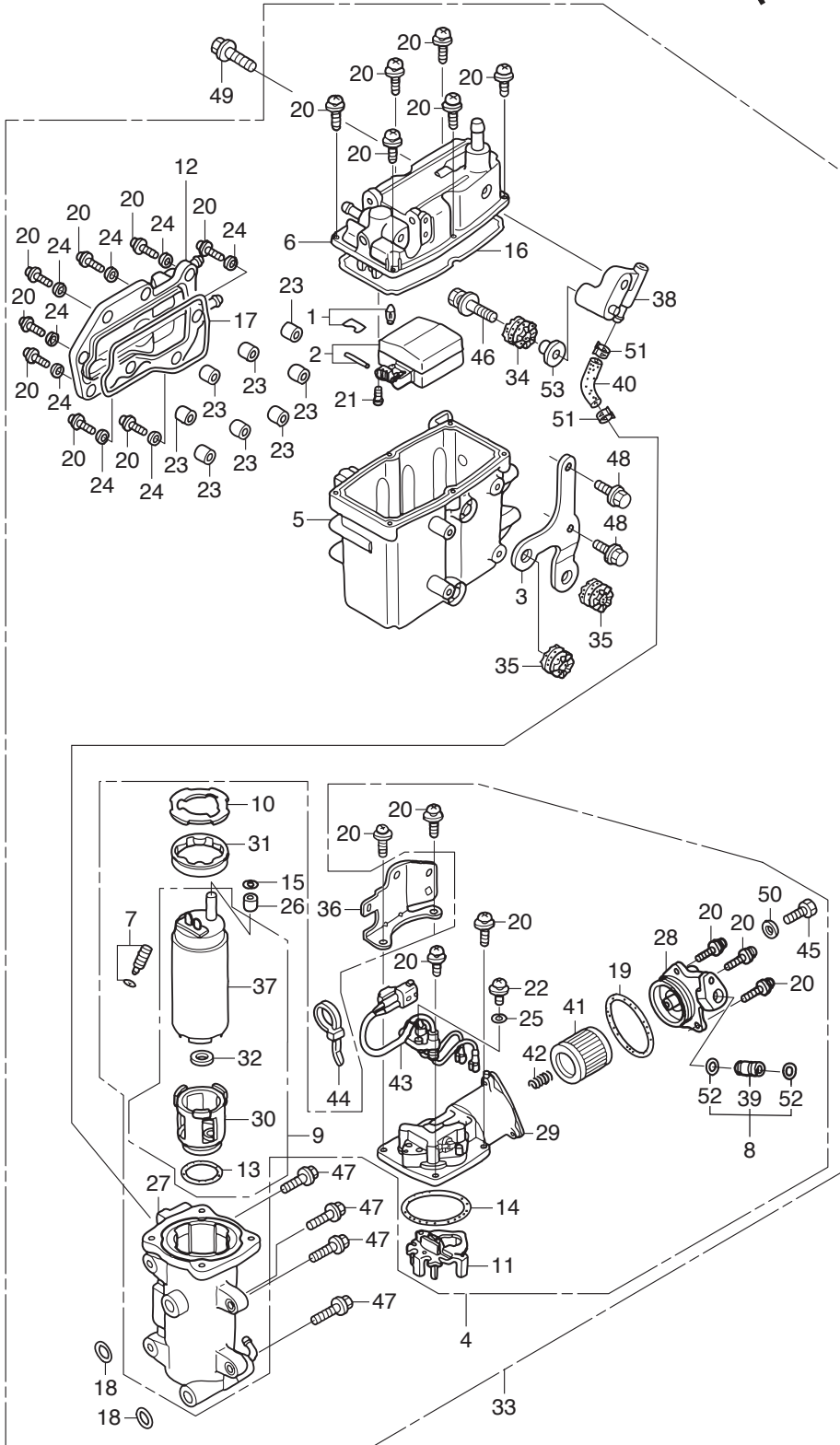



Ref.No.	Part No.	Description	Q' ty	Remarks	
			BFT150A		
E-18-10	30	HZY6-16718-013	INSULATOR COMP.	1	
E-18-10	31	HZY3-16721-000	INSULATOR	1	
E-18-10	32	HZY6-16723-003	RING	1	
E-18-10	33	HZY6-16730-063	SEPARATOR ASSY., VAPOR	1	
E-18-10	34	HZW5-16733-000	GROMMET, VAPOR SEPARATOR	1	
E-18-10	35	HZY3-16733-000	GROMMET, VAPOR SEPARATOR	2	
E-18-10	36	HZY6-16734-003	STAY, PLATE	1	
E-18-10	37	HZW5-16735-003	PUMP UNIT, FUEL	1	
E-18-10	38	HZY6-16736-003	STAY, VAPOR SEPARATOR	1	
E-18-10	39	HZY3-16752-000	JOINT, FUEL PIPE	1	
E-18-10	40	HZY6-16840-A00	TUBE F, FUEL	1	
E-18-10	41	HZY3-16911-010	SCREEN COMP., FUEL STRAINER	1	
E-18-10	42	HZY3-16913-000	SPRING, SET	1	
E-18-10	43	HZY6-32166-003	HARNESS COMP.	1	
E-18-10	44	HZW5-32168-003	BAND	1	
E-18-10	45	HPP4-90009-E01	BOLT, SEALING, 6MM	1	
E-18-10	46	HZW1-90014-000	BOLT-WASHER, 8X35	1	
E-18-10	47	HZW9-90016-000	BOLT, FLANGE, 6X25	4	
E-18-10	48	HZY3-90017-000	BOLT, FLANGE, 6X16	2	
E-18-10	49	HZY3-90049-000	BOLT, FLANGE, 8X30	1	
E-18-10	50	HPD6-90430-003	WASHER, SEALING, 6MM	1	
E-18-10	51	HZY6-90607-000	CLAMP, TUBE(8.0)	2	
E-18-10	52	HMJ0-91301-003	O-RING, 7.8X1.9(ARAI)	2	
E-18-10	53	HZW1-91554-000	COLLAR, 8.5X14.5	1	

FR. 

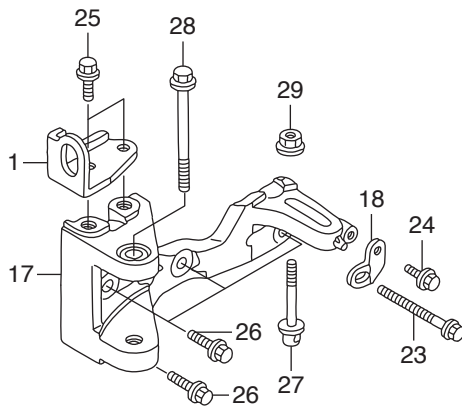
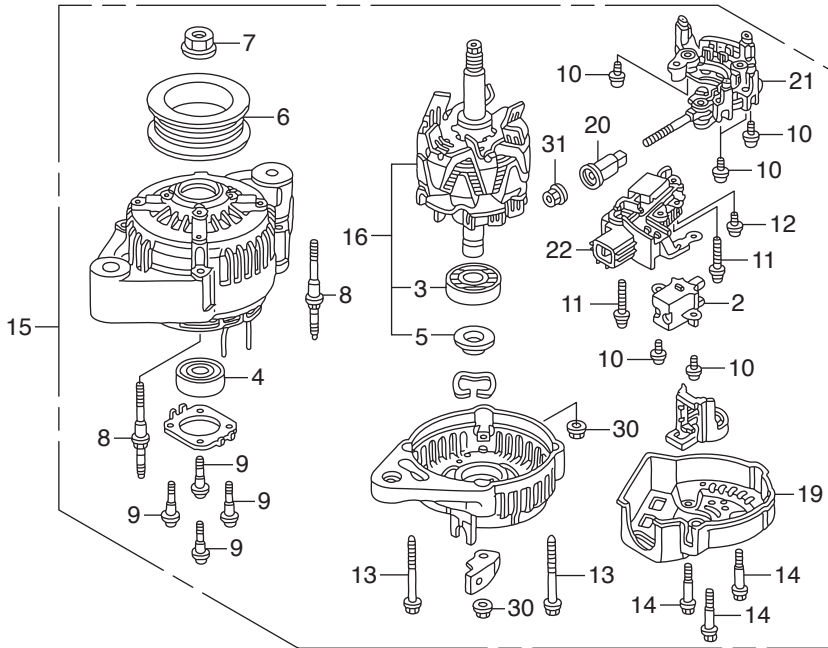

Ref.No.	Part No.	Description	Q' ty	Remarks	
			BFT150A		
E-19	1	HZY6-11912-000	HANGER B, ENGINE	1	
E-19	2	HPZ1-31105-003	HOLDER ASSY., BRUSH	1	
E-19	3	HPJ7-31111-013	BEARING, RR.	1	
E-19	4	HPJ7-31114-013	BEARING, FR.	1	
E-19	5	HPD1-31138-004	COVER, BEARING	1	
E-19	6	HP64-31141-003	PULLEY	1	
E-19	7	HPD1-31142-004	NUT, PULLEY LOCK	1	
E-19	8	HPE9-31145-941	BOLT, STUD	2	
E-19	9	HPJ7-31146-003	SCREW	4	
E-19	10	HPT0-31147-003	SCREW-WASHER	6	
E-19	11	HPD1-31148-004	SCREW-WASHER, 4X25	2	
E-19	12	HPZ1-31149-003	SCREW	1	
E-19	13	HPE9-31152-942	BOLT-WASHER	2	
E-19	14	HPZ1-31153-003	BOLT	3	
E-19	15	HZY6-31630-003	GENERATOR ASSY., A.C.	1	
E-19	16	HZW5-31631-003	ROTOR ASSY.	1	
E-19	17	HZY6-31636-010	BRACKET COMP., A.C. GENERATOR	1	
E-19	18	HZY6-31637-000	STAY, A.C. GENERATOR	1	
E-19	19	HZW5-31639-003	END COVER, RR.	1	
E-19	20	HZW5-31644-003	BUSH, INSULATION	1	
E-19	21	HZW5-31710-003	RECTIFIER ASSY.	1	
E-19	22	HZY6-31750-003	REGULATOR ASSY.	1	
E-19	23	HZW5-90011-010	BOLT, SPECIAL ADJUSTER	1	
E-19	24	HZY3-90017-000	BOLT, FLANGE, 6X16	1	
E-19	25	HZY3-90026-000	BOLT, FLANGE, 8X20	2	
E-19	26	HZY3-90035-000	BOLT, FLANGE, 8X28	4	
E-19	27	HZY3-90055-000	BOLT, TENSIONER	1	
E-19	28	HZW4-90163-000	BOLT, FLANGE, 10X80	1	
E-19	29	HZW5-90203-010	NUT, FLANGE, 8MM	1	

FR. 

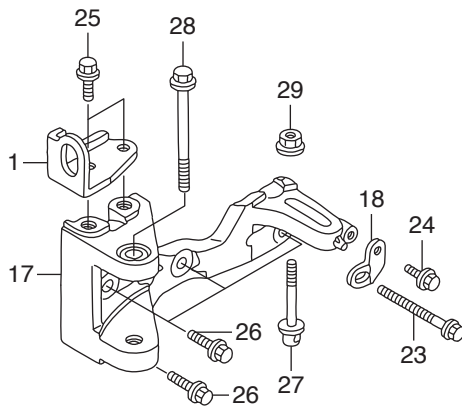
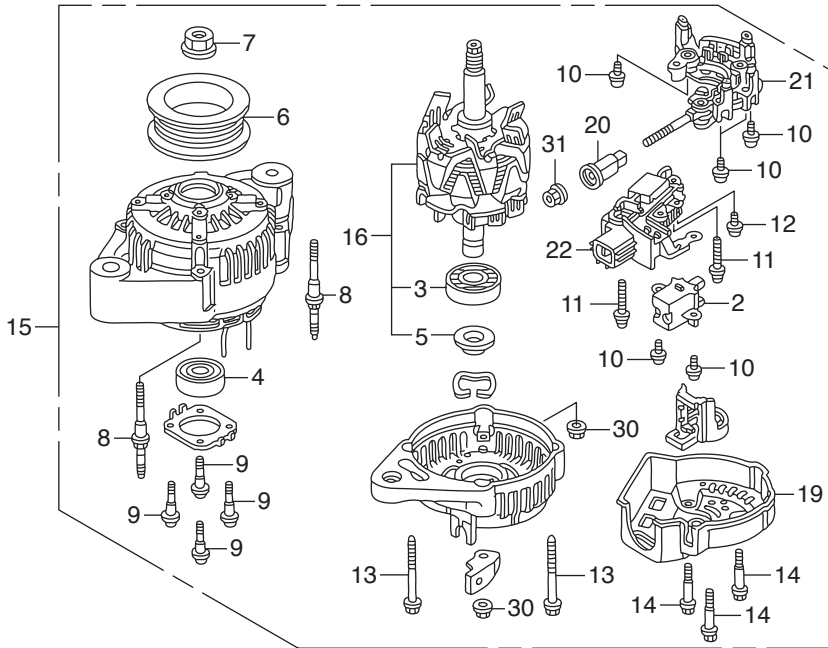



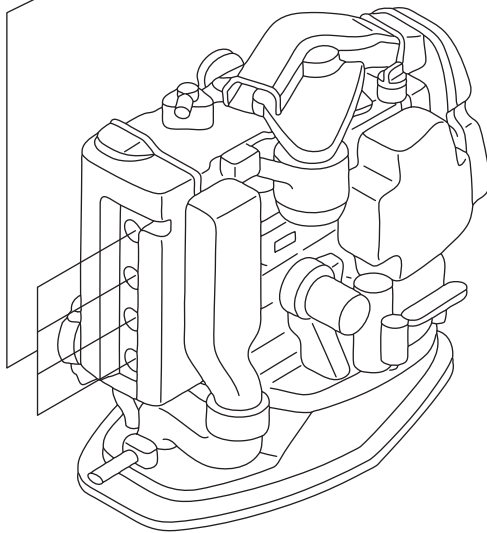
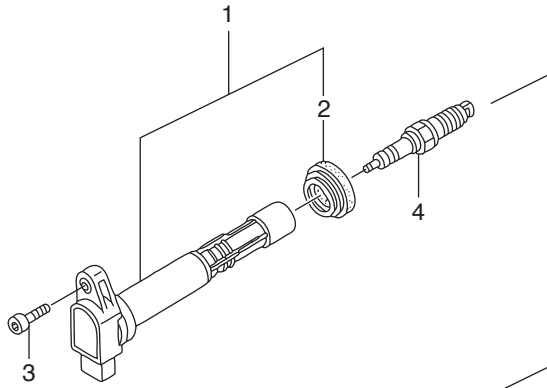

**FR.** →



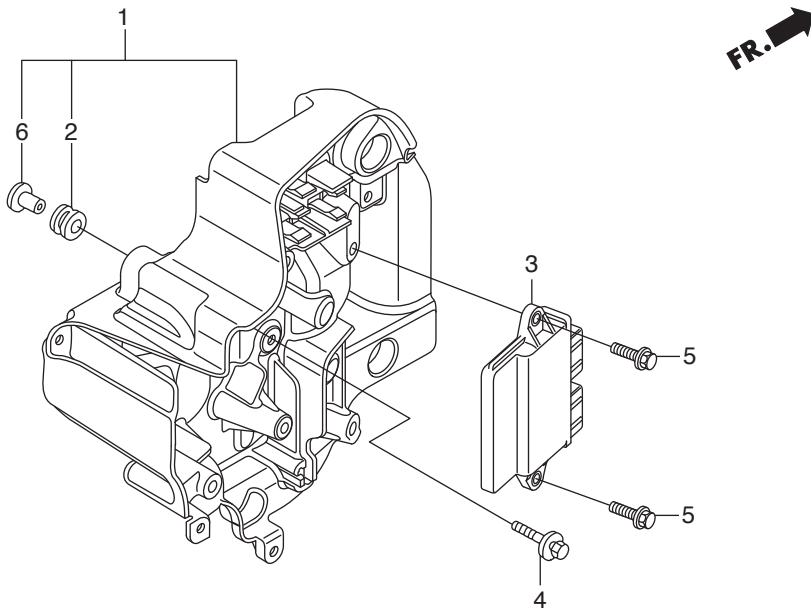





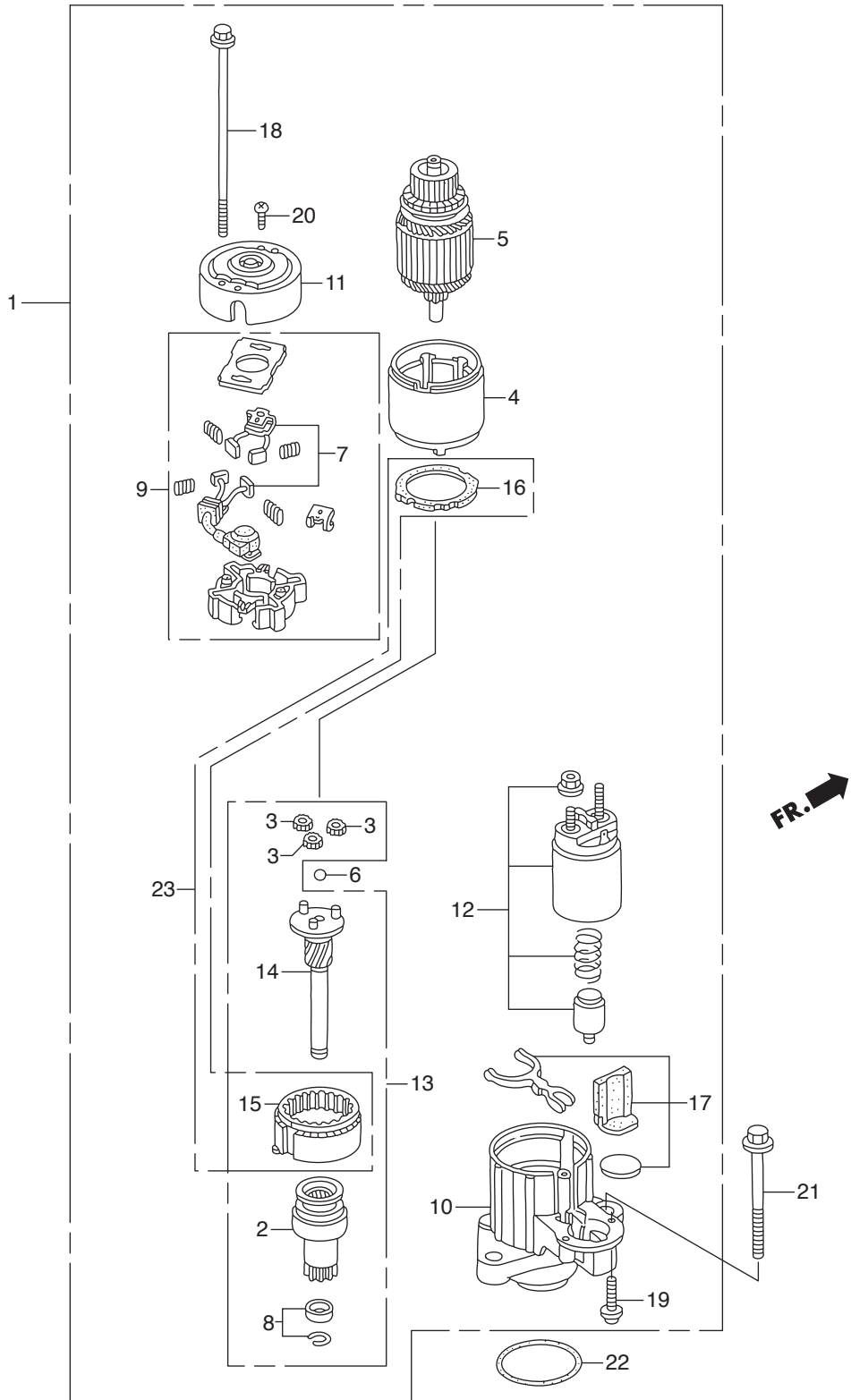

Ref.No.	Part No.	Description	Q' ty	Remarks	
			BFT150A		
E-21	1	HZY6-31200-003	MOTOR ASSY., STARTER	1	
E-21	2	HZY3-31207-003	CLUTCH COMP., OVERRUNNING	1	#~1031330 #~6000198
E-21		HZY9-31207-H01	CLUTCH COMP., OVERRUNNING	1	#1031331~ #6000199~
E-21	3	HPY3-31215-004	GEAR ASSY., PLANETARY	3	
E-21	4	HZY6-31216-003	YOKE COMP.	1	
E-21	5	HZW5-31217-003	ROTOR COMP.	1	
E-21	6	HPY3-31218-004	BALL, STEEL	1	
E-21	7	HZY6-31226-003	BRUSH SET	1	#~1031330 #~6000198
E-21		HZY6-31227-003	BRUSH SET	1	#1031331~ #6000199~
E-21	8	HZW1-31229-004	STOPPER SET, SLEEVE	1	#~1031330 #~6000198
E-21		HZY9-31229-H01	STOPPER SET, SLEEVE	1	#1031331~ #6000199~
E-21	9	HZY6-31231-003	HOLDER COMP., BRUSH	1	#~1031330 #~6000198
E-21		HZY6-31232-003	HOLDER COMP., BRUSH	1	#1031331~ #6000199~
E-21	10	HZY6-31235-003	BRACKET, FR.	1	
E-21	11	HZY6-31236-003	BRACKET, RR.	1	
E-21	12	HZY6-31240-003	SWITCH ASSY., MAGNET	1	#~1031330 #~6000198
E-21		HZY9-31240-003	SWITCH ASSY., MAGNET	1	#1031331~ #6000199~
E-21	13	HZY6-31242-003	SHAFT ASSY., CLUTCH	1	#~1031330 #~6000198
E-21		HZY9-31242-H01	SHAFT ASSY., CLUTCH	1	#1031331~ #6000199~
E-21	14	HZY3-31246-003	SHAFT ASSY., GEAR	1	#~1031330 #~6000198
E-21		HZY9-31246-H01	SHAFT ASSY., GEAR	1	#1031331~ #6000199~
E-21	15	HZW1-31247-004	GEAR ASSY., INTERNAL	1	#~1031330 #~6000198
E-21	16	HZW1-31249-004	PACKING	1	#~1031330 #~6000198
E-21	17	HZW1-31250-004	LEVER SET	1	
E-21	18	HZW1-31261-004	BOLT A, THROUGH	2	
E-21	19	HZW1-90106-004	SCREW, PAN, 6X22(SPECIAL)	2	#~1031330 #~6000198
E-21		HZY9-31226-H01	SCREW, PAN, 6X22	2	#1031331~ #6000199~
E-21	20	HZW1-90107-004	SCREW, PAN, 5X8	2	
E-21	21	HZW4-90164-000	BOLT, FLANGE, 10X90	2	

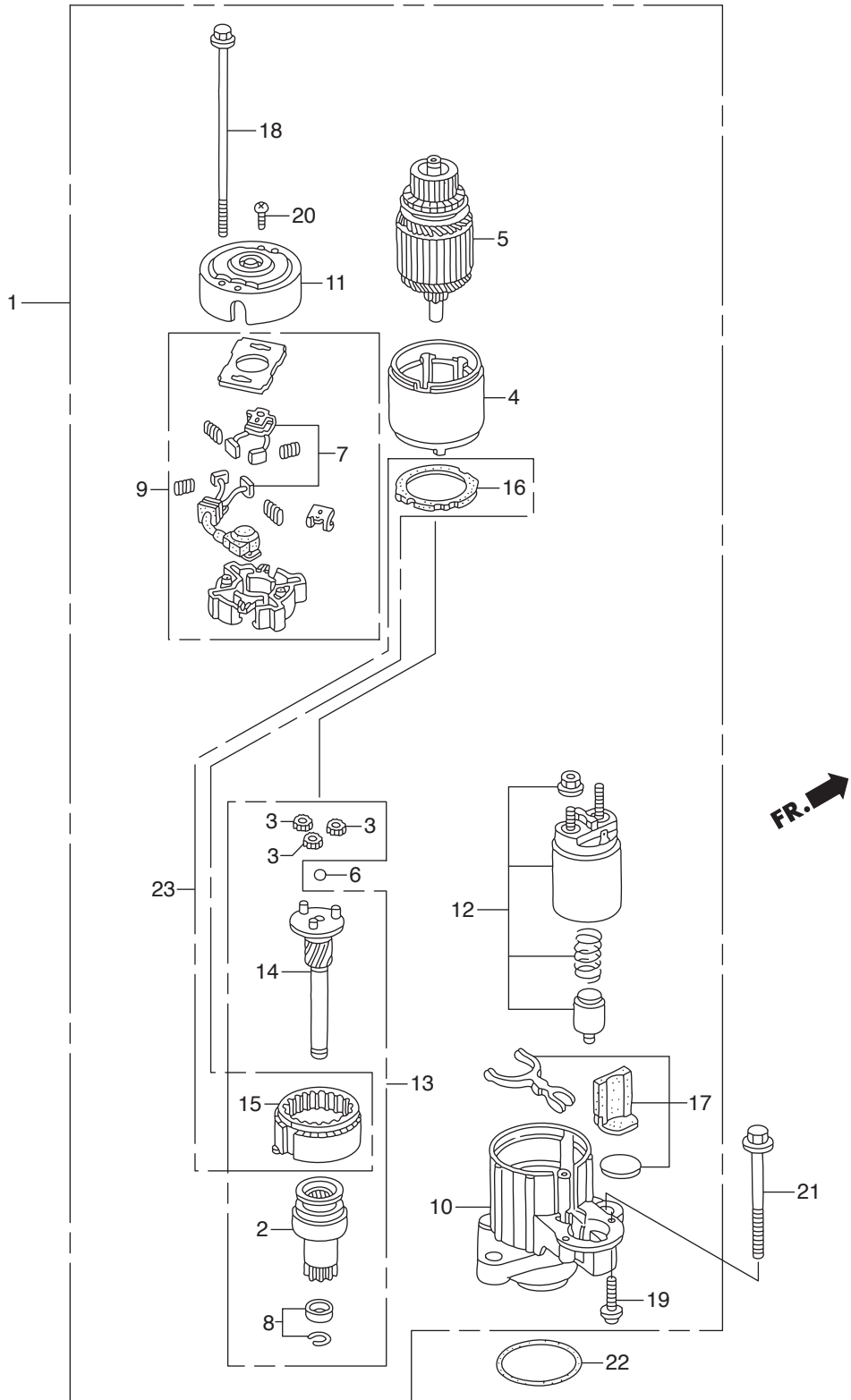



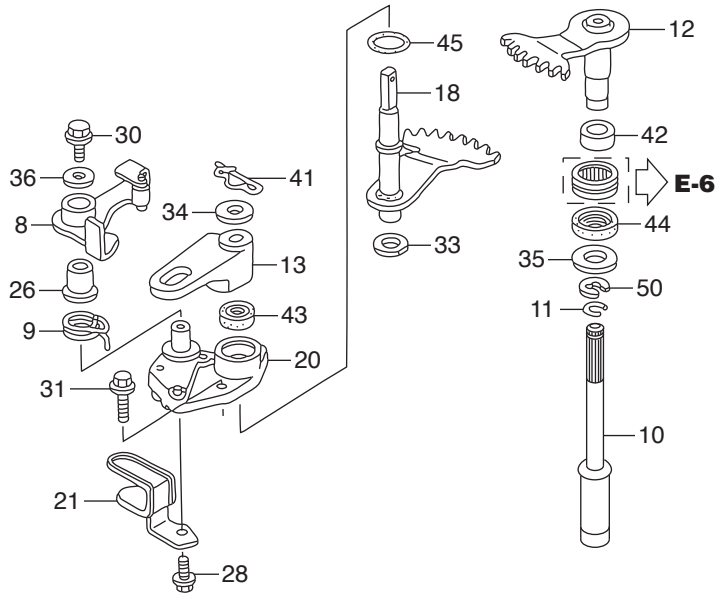
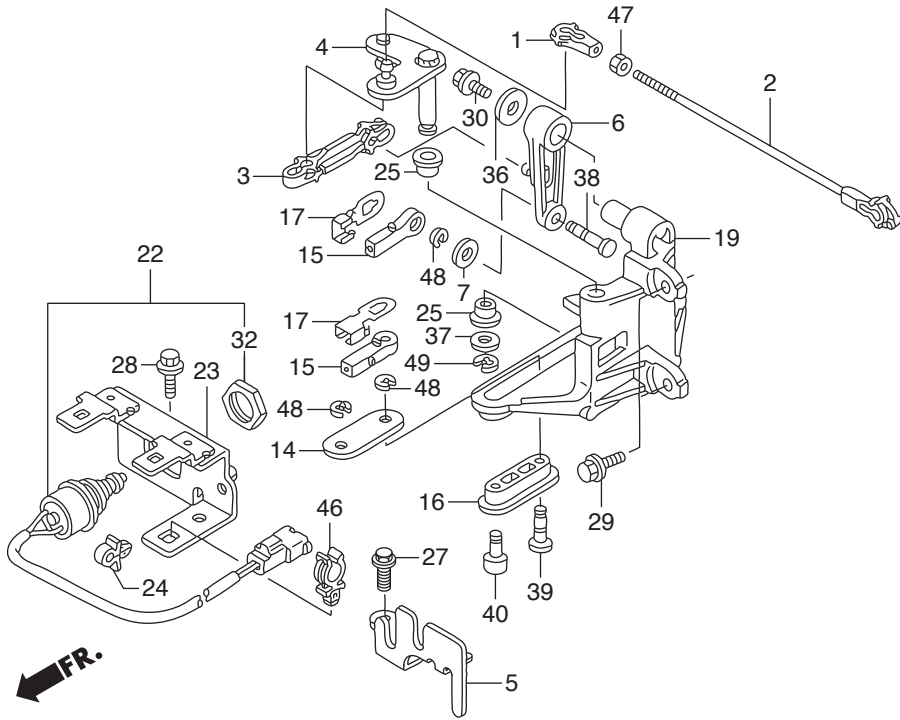

Ref.No.	Part No.	Description	Q' ty	Remarks	
			BFT150A		
F-2	1	HZV5-17838-000	LINKAGE, PIVOT	1	
F-2	2	HZY6-17840-000	ROD COMP., THROTTLE	1	
F-2	3	HZY6-17845-000	LINK, THROTTLE	1	
F-2	4	HZY6-17860-000	PLATE COMP., THROTTLE	1	
F-2	5	HZY6-17877-010	PLATE, REMOTE CONTROL CABLE	1	
F-2	6	HZY6-17931-000	ARM, THROTTLE	1	
F-2	7	H921-17936-000	WASHER, PIVOT	1	
F-2	8	HZY6-24166-000	ARM COMP., CLICK	1	
F-2	9	HZY6-24218-000	SPRING, CLICK	1	
F-2	10	HZY6-24320-000	ROD COMP. A, SHIFT(L)	1	LA
F-2		HZY6-24320-610	ROD COMP. A, SHIFT(XL)	1	XA,XCA
F-2	11	HZW1-24327-000	RING, STOPPER	1	
F-2	12	HZY6-24610-000	SHAFT COMP. A, SHIFT	1	
F-2	13	HZY6-24612-020	ARM, SHIFT	1	
F-2	14	HZY6-24614-000	PLATE, SHIFT PIVOT	1	
F-2	15	HZY3-24618-000	PIVOT, SHIFT	2	
F-2	16	HZY6-24618-000	PIVOT, SHIFT SLIDE	1	
F-2	17	HZY3-24619-000	PLATE, LOCK	2	
F-2	18	HZY6-24620-000	SHAFT COMP. B, SHIFT	1	
F-2	19	HZY6-24628-000	BRACKET, SHIFT LINK	1	
F-2	20	HZY6-24629-000ZA	HOLDER, SEAL	1	*NH8* DARK GRAY
F-2	21	HZY6-32418-000	BRACKET A, CABLE	1	
F-2	22	HZY3-35470-023	SWITCH ASSY., NEUTRAL	1	
F-2	23	HZY6-35475-000	BRACKET, NEUTRAL SWITCH	1	
F-2	24	HVM0-46391-003	CLIP, BRAKE PIPE(A)	1	
F-2	25	HZY3-63205-000	BUSH A, COVER LOCK	2	
F-2	26	H763-75538-C01	BUSH, BLADE BRAKE	1	
F-2	27	HZY3-90017-000	BOLT, FLANGE, 6X16	1	
F-2	28	HZY3-90021-000	BOLT, FLANGE, 6X14	2	

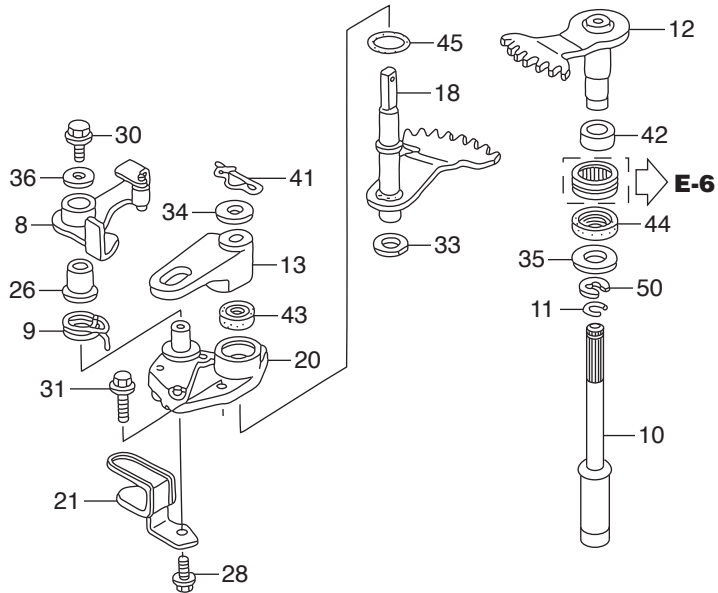
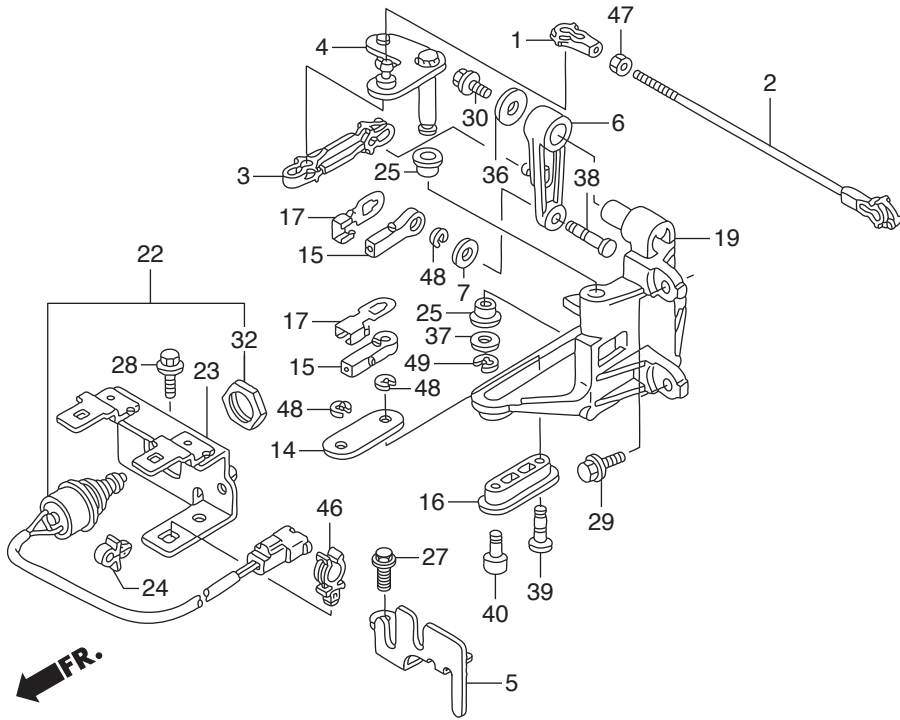



Ref.No.	Part No.	Description	Q' ty	Remarks	
			BFT150A		
F-2	29	HZY3-90028-000	BOLT, FLANGE, 6X18	2	
F-2	30	HZW9-90102-000	BOLT, FLANGE, 6X12	2	
F-2	31	HZW9-90105-000	BOLT, FLANGE, 6X20	2	
F-2	32	HZV5-90302-003	NUT, HEX., 20MM	1	
F-2	33	H958-90428-000	WASHER B, THRUST, 14MM	1	
F-2	34	HZY3-90507-000	WASHER, PLAIN, 12MM	1	
F-2	35	HZV7-90508-000	WASHER	1	
F-2	36	HZV4-90512-000	WASHER, PLAIN, 6MM	2	
F-2	37	H921-90518-000	WASHER, PLAIN, 8MM	1	
F-2	38	HZY3-90751-000	PIN, LINK	1	
F-2	39	HZY6-90752-000	PIN, SHIFT LINK	1	
F-2	40	HZY6-90753-000	PIN, LINK	1	
F-2	41	HZY6-90755-003	PIN, SNAP, 12MM	1	
F-2	42	HZY3-91152-003	RING, INNER(15X20X23)	1	
F-2	43	HZW5-91251-003	OIL SEAL, 14X26X6	1	
F-2	44	HZY3-91255-003	SEAL, WATER(14X26X8)	1	
F-2	45	HP0X-91321-003	O-RING, 25X2.4(NOK)	1	
F-2	46	HSV1-91549-L01	HOLDER, DRAIN TUBE	1	
F-2	47	HCO-94001-05490-0S	NUT, HEX., 5MM	1	
F-2	48	HCO-94540-04029	E-RING, 4MM	3	
F-2	49	HCO-94540-06029	E-RING, 6MM	1	
F-2	50	HCO-94540-12029	E-RING, 12MM	1	

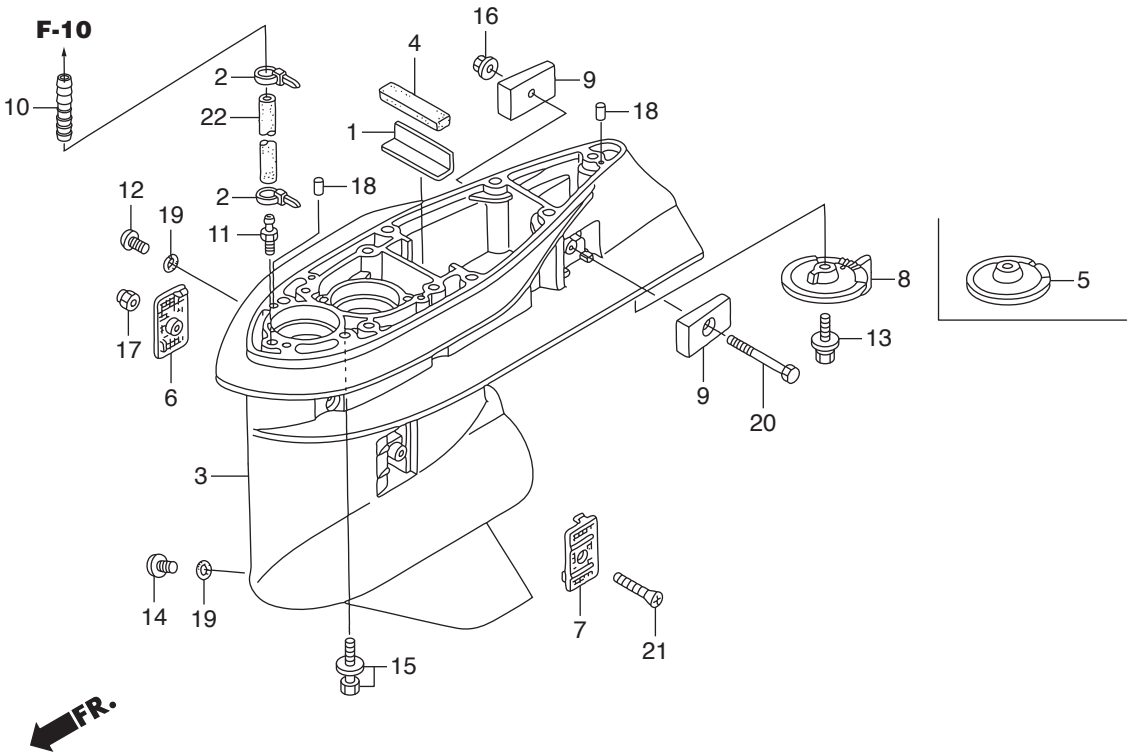

Ref.No.	Part No.	Description	Q' ty	Remarks	
			BFT150A		
F-3	1	HZW1-19286-B00	PLATE, RUBBER SETTING	1	
F-3	2	HKM3-32161-003	BAND, WIRE	2	
F-3	3	HZY6-41101-020ZC	CASE, GEAR	1	*T107* BAY BLUE
F-3	4	HZW1-41102-B00	GROMMET, GEAR CASE	1	
F-3	5	HZX2-41102-E00ZC	COVER, GEAR CASE	1	*T107* BAY BLUE XCA
F-3	6	HZY6-41104-010	SCREEN, R. WATER	1	
F-3	7	HZY6-41105-010	SCREEN, L. WATER	1	
F-3	8	HZX2-41107-C00ZC	TAB, TRIM	1	*T107* BAY BLUE LA,XA
F-3	9	HZW1-41109-B00	METAL COMP., ANODE	2	
F-3	10	HZV5-41171-000	END, NIPPLE	1	
F-3	11	HZV5-41172-000	NIPPLE, SENSOR	1	
F-3	12	HZW9-90101-003	BOLT, OIL CHECK	1	
F-3	13	HZY6-90103-000	BOLT-WASHER, 10X32	1	
F-3	14	HZY3-90120-000	BOLT, DRAIN PLUG	1	
F-3	15	HZY6-90123-000	BOLT-WASHER, 10X40	7	
F-3	16	HZY1-90205-000	NUT, SELF-LOCK, 6MM	1	
F-3	17	HZV4-90302-000	NUT, SELF-LOCK, 5MM	1	
F-3	18	HZV5-90756-000	DOWEL PIN, 6X10	2	
F-3	19	HZW4-91301-003	O-RING, 6.9X1.45	2	
F-3	20	HCO-92101-06050-4J	BOLT, HEX., 6X50	1	
F-3	21	HCO-93700-05050-4J	SCREW, OVAL, 5X50	1	
F-3	22	HCO-95005-50140-30	TUBE, 5X140	1	(HC-95005-50001-30M) LA
F-3		HCO-95005-50270-30	TUBE, 5X270	1	(HC-95005-50001-30M) XA,XCA

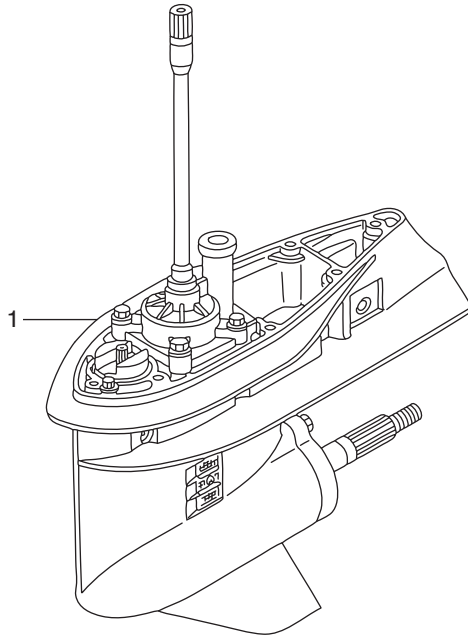

**FR.**



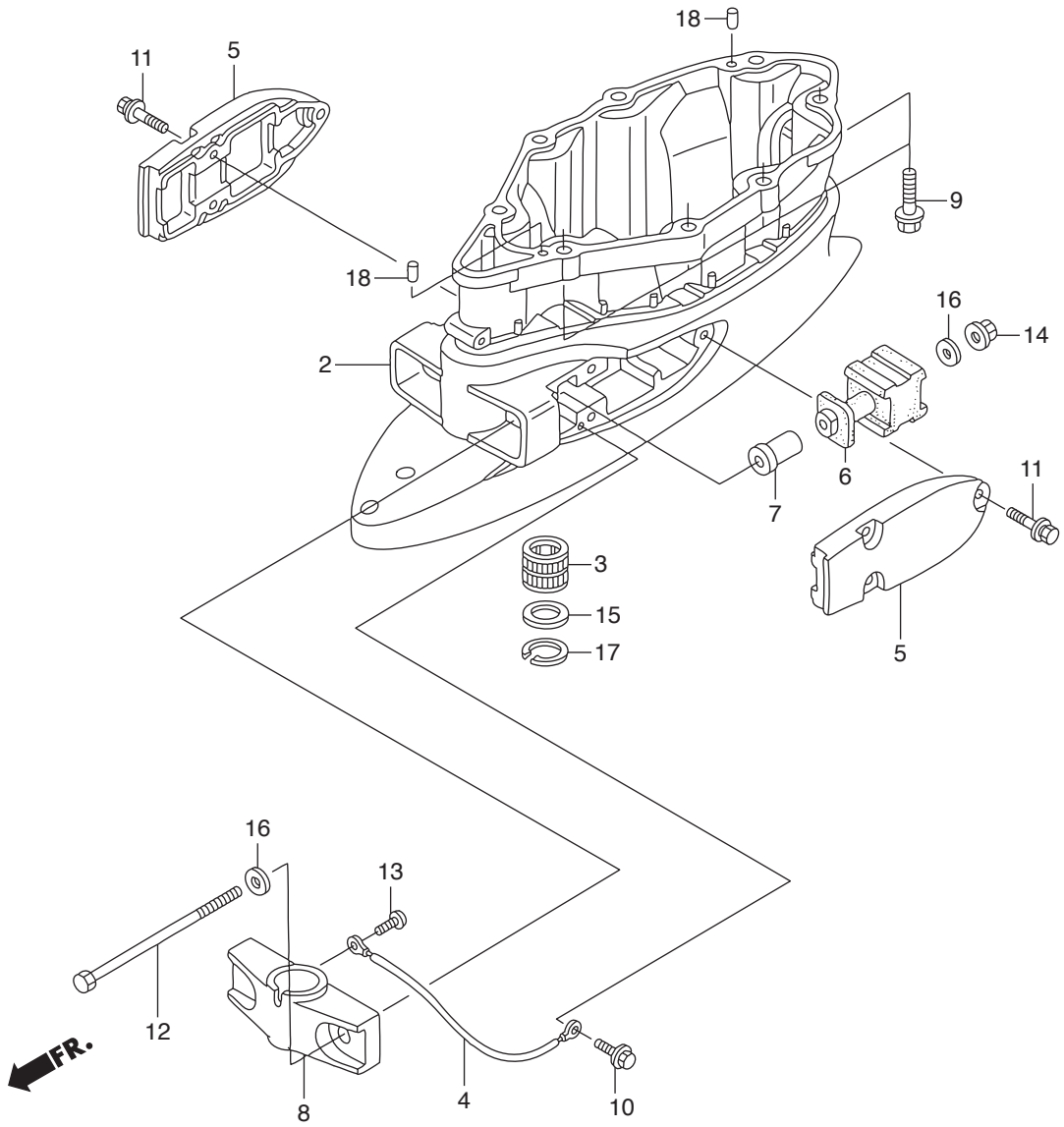



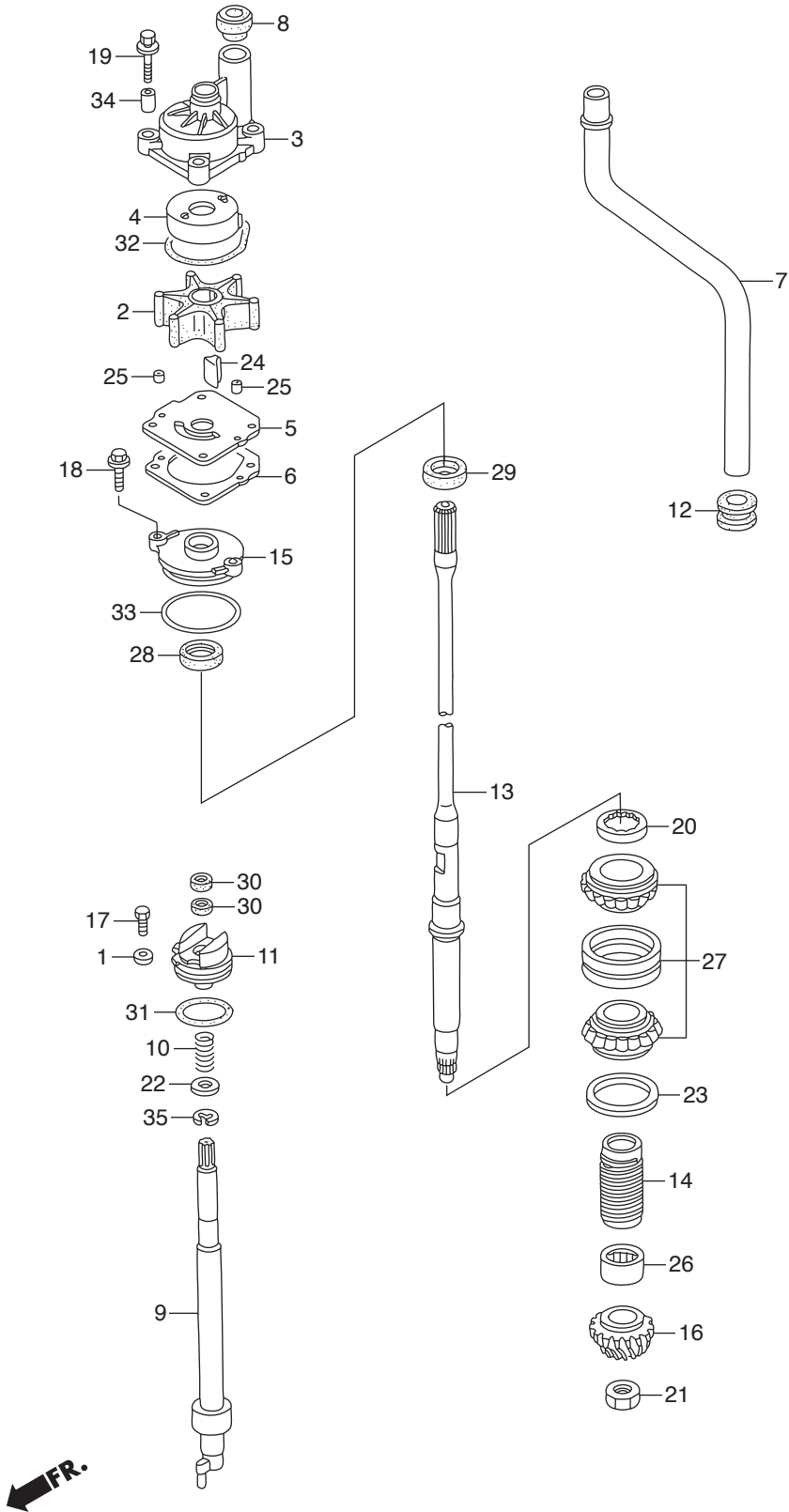



Ref.No.	Part No.	Description	Q' ty	Remarks	
			BFT150A		
F-4	1	H921-17936-000	WASHER, PIVOT	1	
F-4	2	HZW1-19210-B04	IMPELLER, PUMP	1	
F-4	3	HZY6-19221-A00	HOUSING, IMPELLER	1	
F-4	4	HZW1-19223-B00	LINER, PUMP	1	
F-4	5	HZY6-19231-000	COVER, IMPELLER	1	
F-4	6	HZY6-19234-000	GASKET B, IMPELLER	1	
F-4	7	HZY6-19251-000	TUBE, WATER(L)	1	LA
F-4		HZY6-19251-611	TUBE, WATER(XL)	1	XA,XCA
F-4	8	HZW1-19253-B01	RING, WATER TUBE SEAL	1	
F-4	9	HZY6-24310-000	ROD COMP., SHIFT	1	LA,XA
F-4		HZY6-24310-710	ROD COMP., SHIFT	1	(COUNTER ROTATION) XCA
F-4	10	HZY3-24318-000	SPRING, SHIFT ROD	1	
F-4	11	HZY6-24343-000	HOLDER, SHIFT ROD	1	
F-4	12	HZW1-40204-000	GROMMET, EXTENSION CASE	1	
F-4	13	HZY6-41112-010	SHAFT, VERTICAL(L)	1	LA
F-4		HZY6-41112-611	SHAFT, VERTICAL(XL)	1	XA,XCA
F-4	14	HZW1-41116-B00	SLINGER, OIL	1	
F-4	15	HZZ3-41117-000	HOUSING, WATER SEAL	1	
F-4	16	HZY6-41131-000	GEAR, PINION	1	
F-4	17	H881-90105-000	BOLT, HEX., 6X12	1	
F-4	18	HZW9-90105-000	BOLT, FLANGE, 6X20	2	
F-4	19	HZY6-90116-000	BOLT-WASHER, 8X40	4	
F-4	20	HZW1-90242-000	NUT, LOCK, 64MM	1	
F-4	21	HZW5-90303-000	NUT, HEX., 18MM	1	
F-4	22	H723-90472-000	WASHER, PLAIN, 12MM	1	
F-4	23	HZW1-90518-B00	SHIM A, GEAR(0.10)	1	
F-4		HZW1-90519-B00	SHIM B, GEAR(0.15)	1	
F-4		HZW1-90520-B00	SHIM C, GEAR(0.30)	1	
F-4		HZW1-90521-B00	SHIM D, GEAR(0.50)	1	

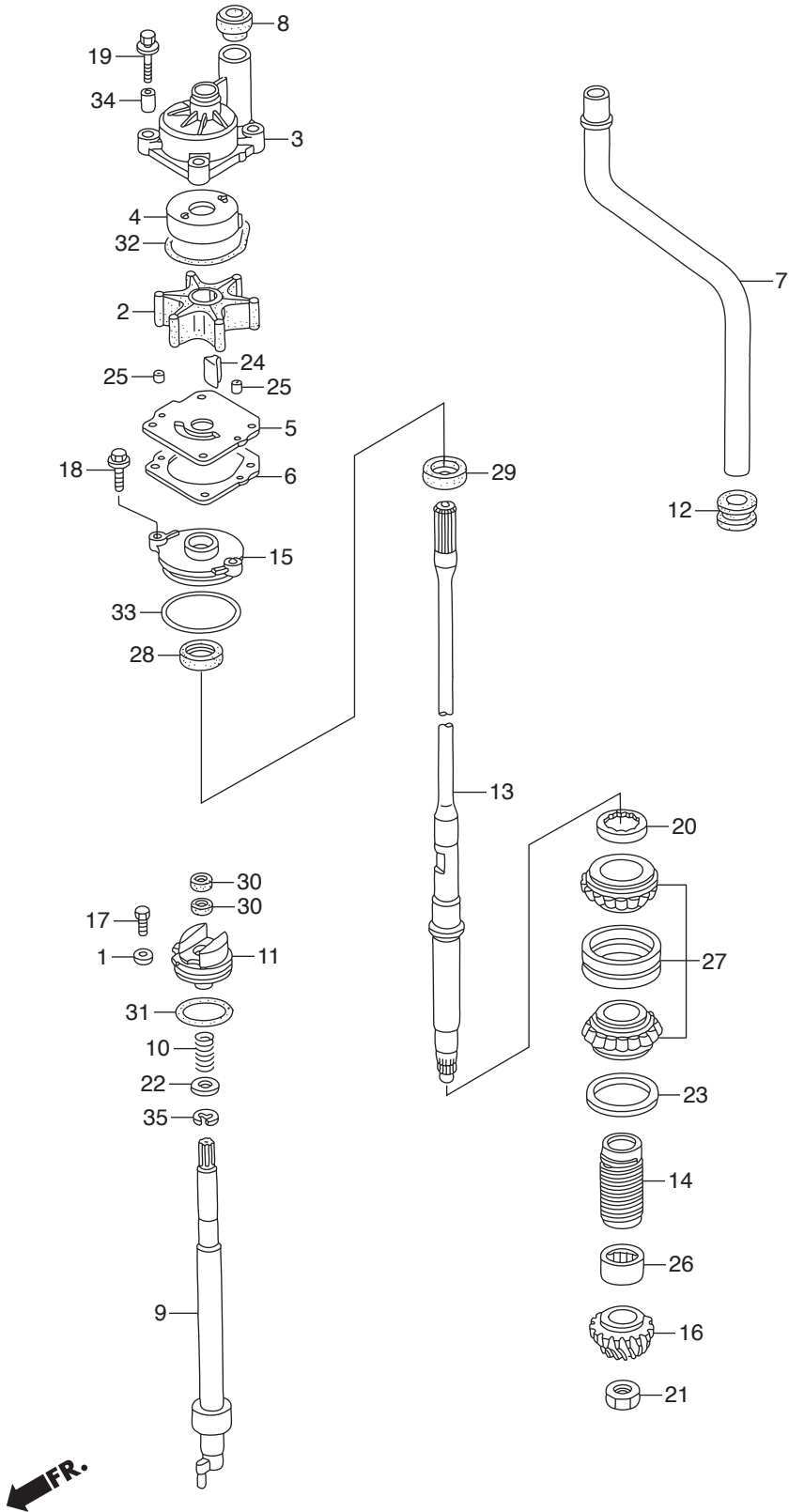



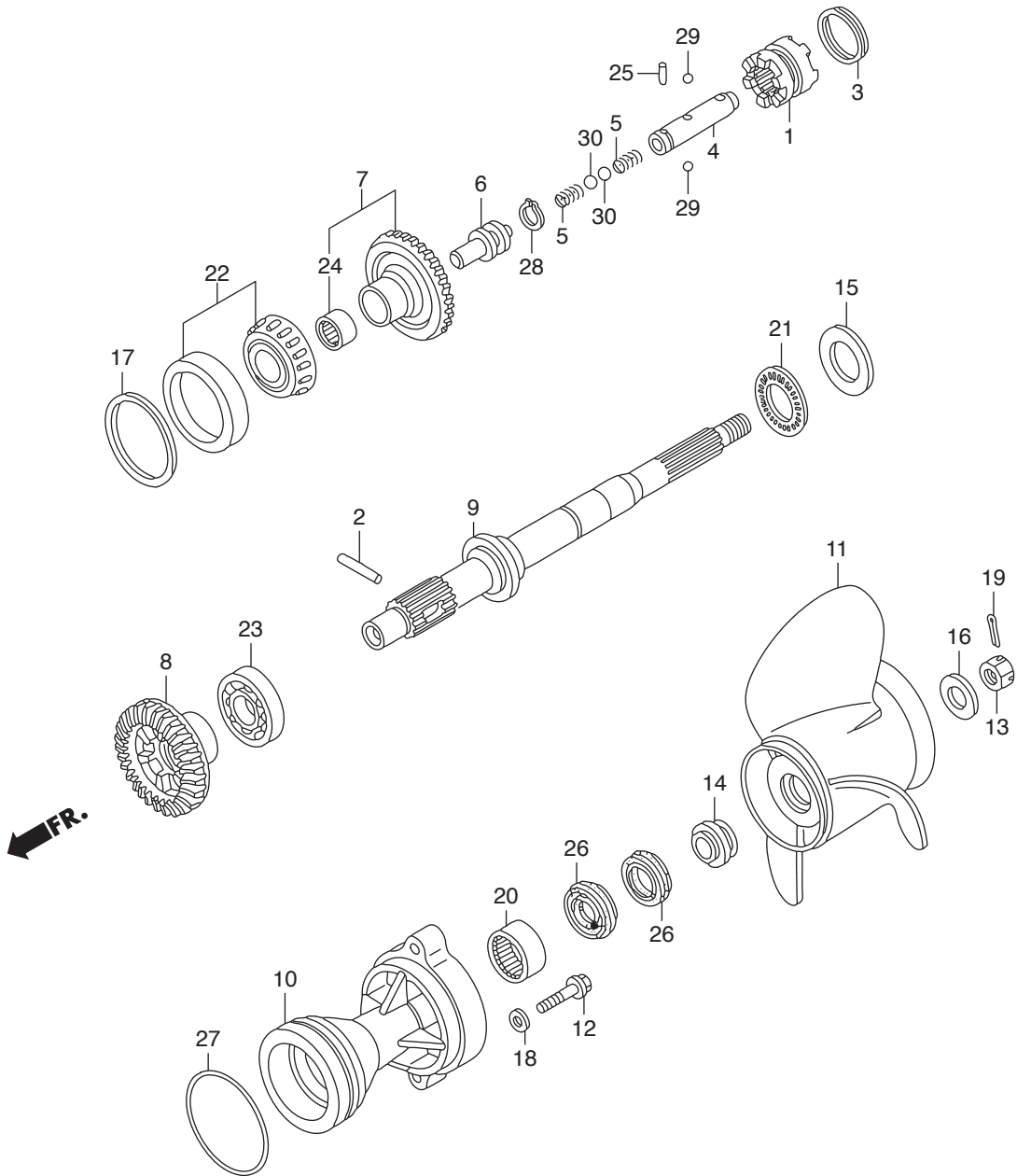

Ref.No.	Part No.	Description	Q' ty	Remarks	
			BFT150A		
F-5	1	HZY6-24101-000	SHIFTER, CLUTCH	1	LA,XA
F-5	2	HZW1-24102-B00	PIN, SHIFTER, 8X47	1	LA,XA
F-5	3	HZW1-24103-B00	RING, CROSS PIN	1	LA,XA
F-5	4	HZY6-24122-000	SLIDER, SHIFT	1	LA,XA
F-5	5	HZY6-24123-000	SPRING, SHIFT	2	LA,XA
F-5	6	HZY6-24124-000	PLATE, SHIFT	1	LA,XA
F-5	7	HZY6-41140-000	GEAR COMP., BEVEL(FORWARD 30T)	1	LA,XA
F-5	8	HZY6-41151-000	GEAR, BEVEL(RVS. 30T)	1	LA,XA
F-5	9	HZY6-41161-000	SHAFT, PROPELLER	1	LA,XA
F-5	10	HZY6-41201-000ZC	HOLDER, PROPELLER SHAFT	1	*T107* BAY BLUE LA,XA
F-5	11	HZY3-58130-T00	PROPELLER COMP., THREE BLADES	1	(14-1/2X15)(SUS) LA,XA
F-5		HZY3-58130-T10	PROPELLER COMP., THREE BLADES	1	(14-1/4X17)(SUS) LA,XA
F-5		HZY3-58130-T20	PROPELLER COMP., THREE BLADES	1	(14X19)(SUS) LA,XA
F-5		HZY3-58130-T30	PROPELLER COMP., THREE BLADES	1	(14X21)(SUS) LA,XA
F-5		HZY3-58130-T40	PROPELLER COMP., THREE BLADES	1	(14-1/2X23)(SUS) LA,XA
F-5		HZY3-58130-T50	PROPELLER COMP., THREE BLADES	1	(14X25)(SUS) LA,XA
F-5		HZY3-58130-V01ZA	PROPELLER COMP., THREE BLADES	1	(15-1/2X13)(AL) *NH283* STIN GRAY LA,XA
F-5		HZY3-58130-V11ZA	PROPELLER COMP., THREE BLADES	1	(15-1/4X15)(AL) *NH283* STIN GRAY LA,XA
F-5		HZY3-58130-V21ZA	PROPELLER COMP., THREE BLADES	1	(15X17)(AL) *NH283* STIN GRAY LA,XA
F-5		HZY3-58130-V31ZA	PROPELLER COMP., THREE BLADES	1	(14-3/4X19)(AL) *NH283* STIN GRAY LA,XA
F-5		HZY3-58130-V41ZA	PROPELLER COMP., THREE BLADES	1	(14-1/2X21)(AL) *NH283* STIN GRAY LA,XA
F-5		HZY3-58130-V51ZA	PROPELLER COMP., THREE BLADES	1	(14-1/4X23)(AL) *NH283* STIN GRAY LA,XA
F-5	12	HZY6-90104-000	BOLT, FLANGE, 10X40	2	LA,XA
F-5	13	HZW1-90301-B00	NUT, CASTLE, 18MM	1	LA,XA
F-5	14	HZY3-90506-000	WASHER, PROPELLER THRUST	1	LA,XA
F-5	15	HZW5-90509-711	WASHER, THRUST BEARING	1	LA,XA
F-5	16	HZY3-90512-000	WASHER, PROPELLER	1	LA,XA
F-5	17	HZY3-90528-000	SHIM A, BEVEL(0.10)	1	LA,XA
F-5		HZY3-90529-000	SHIM B, BEVEL(0.15)	1	LA,XA

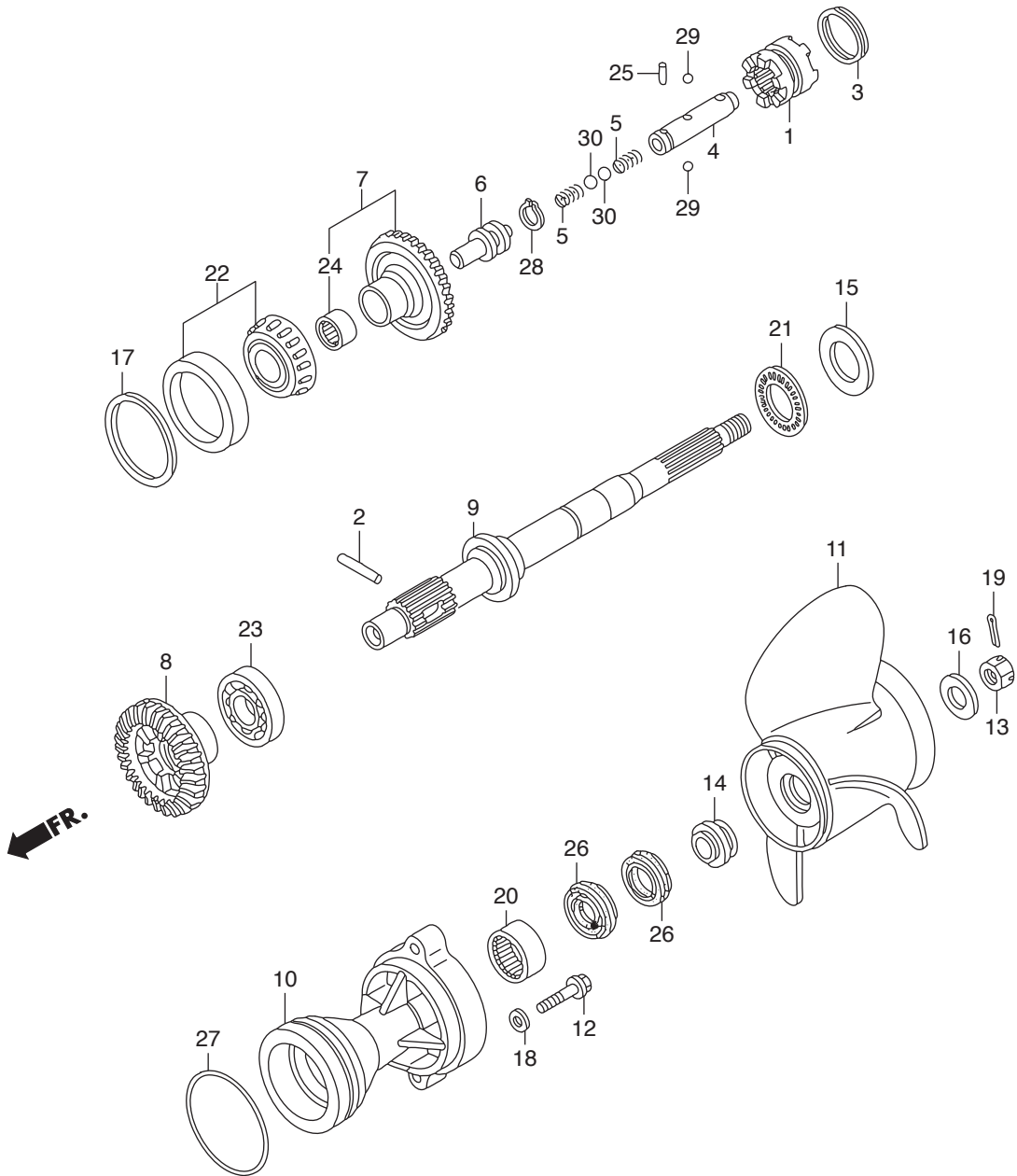



PROPELLER SHAFT/PROPELLER  
(COUNTER ROTATION)

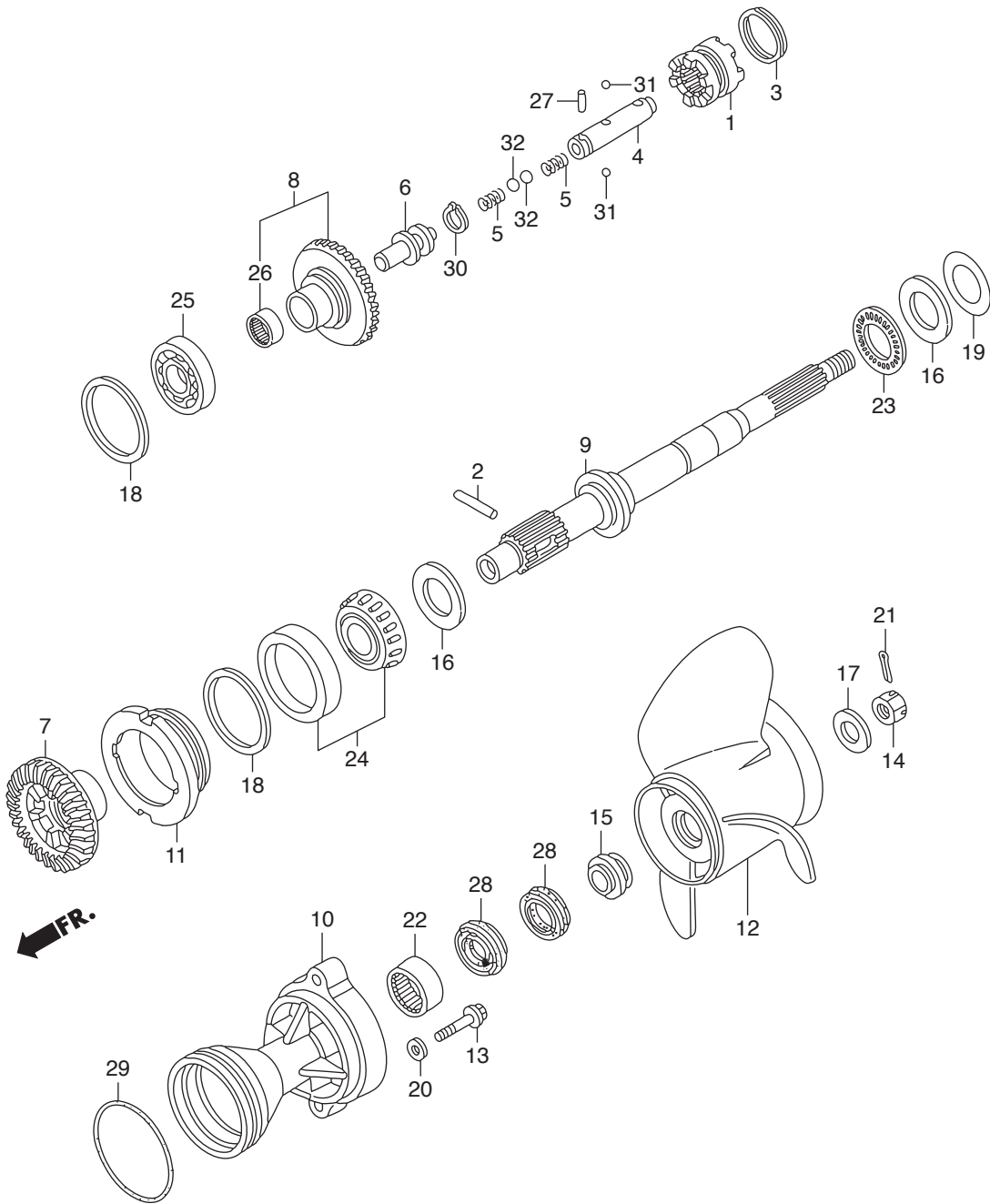



Ref.No.	Part No.	Description	Q' ty	Remarks	
			BFT150A		
F-5-1	1	HZY6-24101-000	SHIFTER, CLUTCH	1	XCA
F-5-1	2	HZW1-24102-B00	PIN, SHIFTER, 8X47	1	XCA
F-5-1	3	HZW1-24103-B00	RING, CROSS PIN	1	XCA
F-5-1	4	HZY6-24122-000	SLIDER, SHIFT	1	XCA
F-5-1	5	HZY6-24123-000	SPRING, SHIFT	2	XCA
F-5-1	6	HZY6-24124-000	PLATE, SHIFT	1	XCA
F-5-1	7	HZY6-41141-710	GEAR, BEVEL(FORWARD 30T)	1	(COUNTER ROTATION) XCA
F-5-1	8	HZY6-41150-710	GEAR COMP., BEVEL(RVS. 30T)	1	(COUNTER ROTATION) XCA
F-5-1	9	HZY6-41161-710	SHAFT, PROPELLER	1	(COUNTER ROTATION) XCA
F-5-1	10	HZY6-41201-710ZC	HOLDER, PROPELLER SHAFT	1	*T107* BAY BLUE XCA
F-5-1	11	HZY6-41202-710	HOLDER, BEARING	1	(COUNTER ROTATION) XCA
F-5-1	12	HZY3-58180-T00	PROPELLER COMP., THREE BLADES	1	(14-1/2X15)(C/R) XCA
F-5-1		HZY3-58180-T10	PROPELLER COMP., THREE BLADES	1	(14-1/4X17)(C/R) XCA
F-5-1		HZY3-58180-T20	PROPELLER COMP., THREE BLADES	1	(14X19)(C/R) XCA
F-5-1		HZY3-58180-T30	PROPELLER COMP., THREE BLADES	1	(14X21)(C/R) XCA
F-5-1		HZY3-58180-T40	PROPELLER COMP., THREE BLADES	1	(14-1/2X23)(C/R) XCA
F-5-1	13	HZY6-90104-000	BOLT, FLANGE, 10X40	2	XCA
F-5-1	14	HZW1-90301-B00	NUT, CASTLE, 18MM	1	XCA
F-5-1	15	HZY3-90506-000	WASHER, PROPELLER THRUST	1	XCA
F-5-1	16	HZW5-90509-711	WASHER, THRUST BEARING	2	XCA
F-5-1	17	HZY3-90512-000	WASHER, PROPELLER	1	XCA
F-5-1	18	HZY3-90528-000	SHIM A, BEVEL(0.10)	2	XCA
F-5-1		HZY3-90529-000	SHIM B, BEVEL(0.15)	2	XCA
F-5-1		HZY3-90530-000	SHIM C, BEVEL(0.30)	2	XCA
F-5-1		HZY3-90531-000	SHIM D, BEVEL(0.50)	2	XCA
F-5-1	19	HZW5-90548-710	SHIM A, THRUST(0.10)	1	XCA
F-5-1		HZW5-90549-710	SHIM B, THRUST(0.15)	1	XCA
F-5-1		HZW5-90550-710	SHIM C, THRUST(0.30)	1	XCA
F-5-1		HZW5-90551-710	SHIM D, THRUST(0.50)	1	XCA

PROPELLER SHAFT/PROPELLER  
(COUNTER ROTATION)

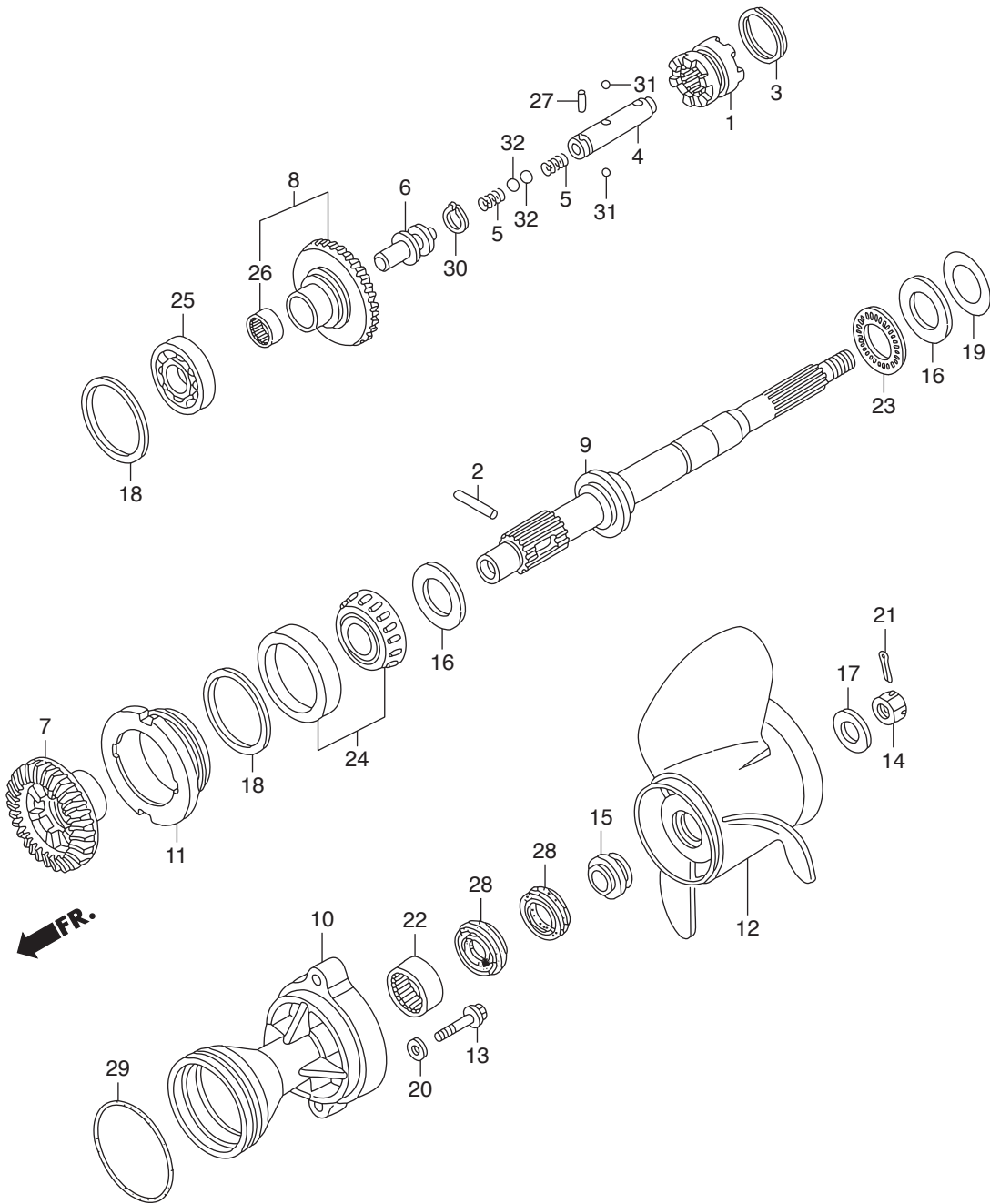



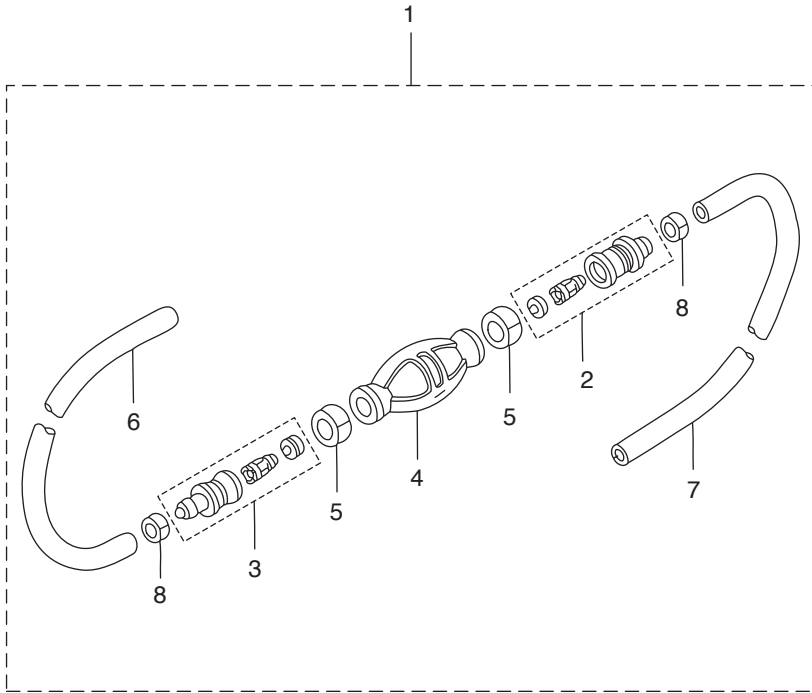



FR. →

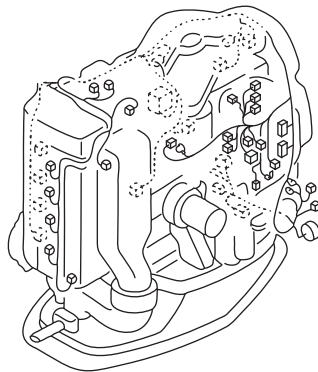
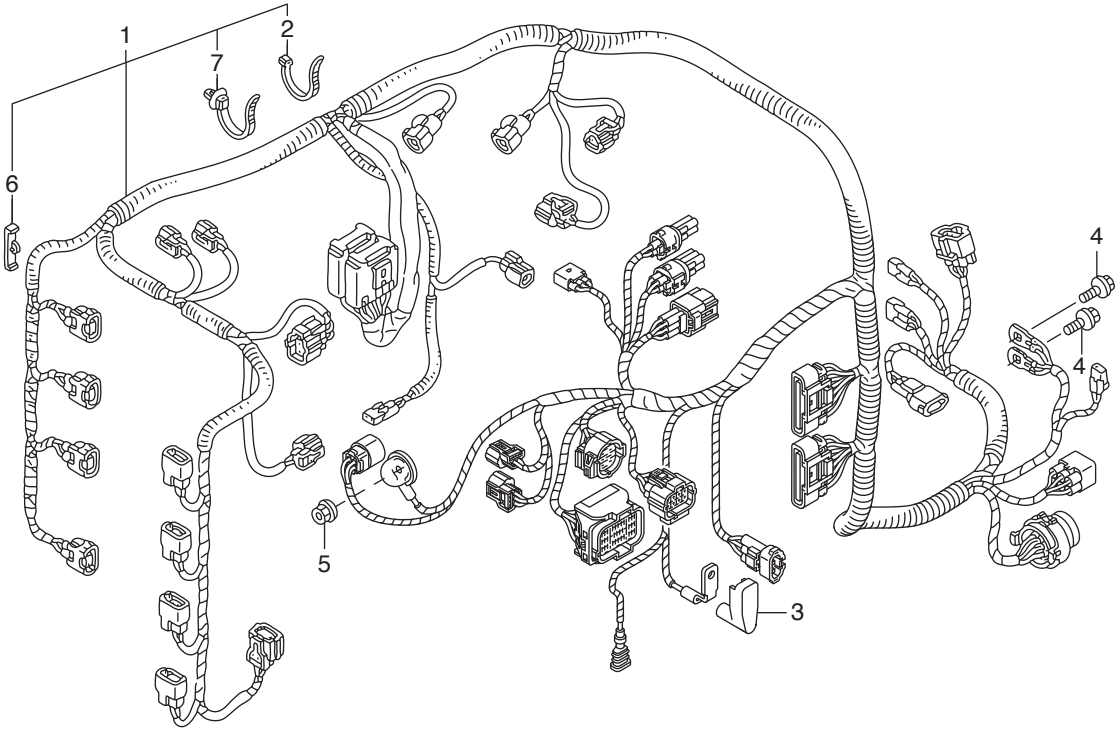



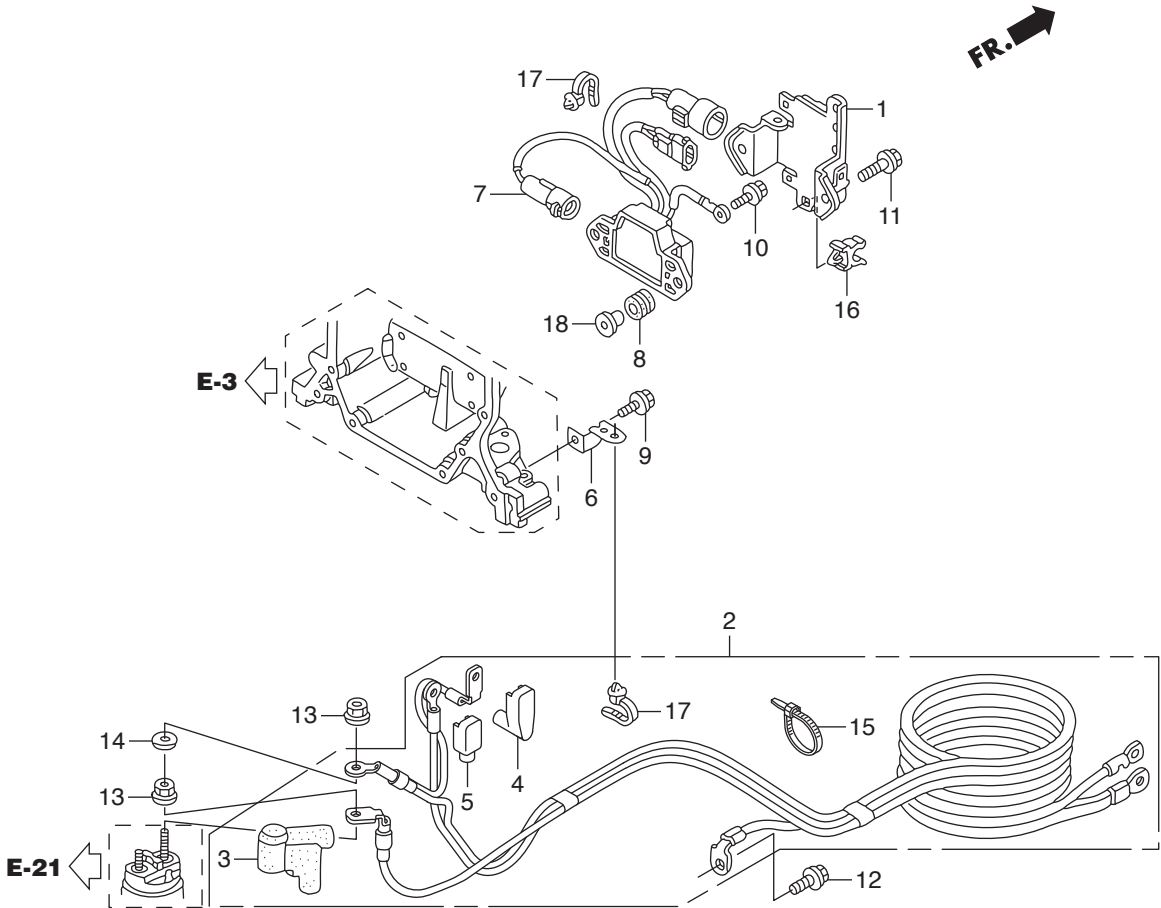





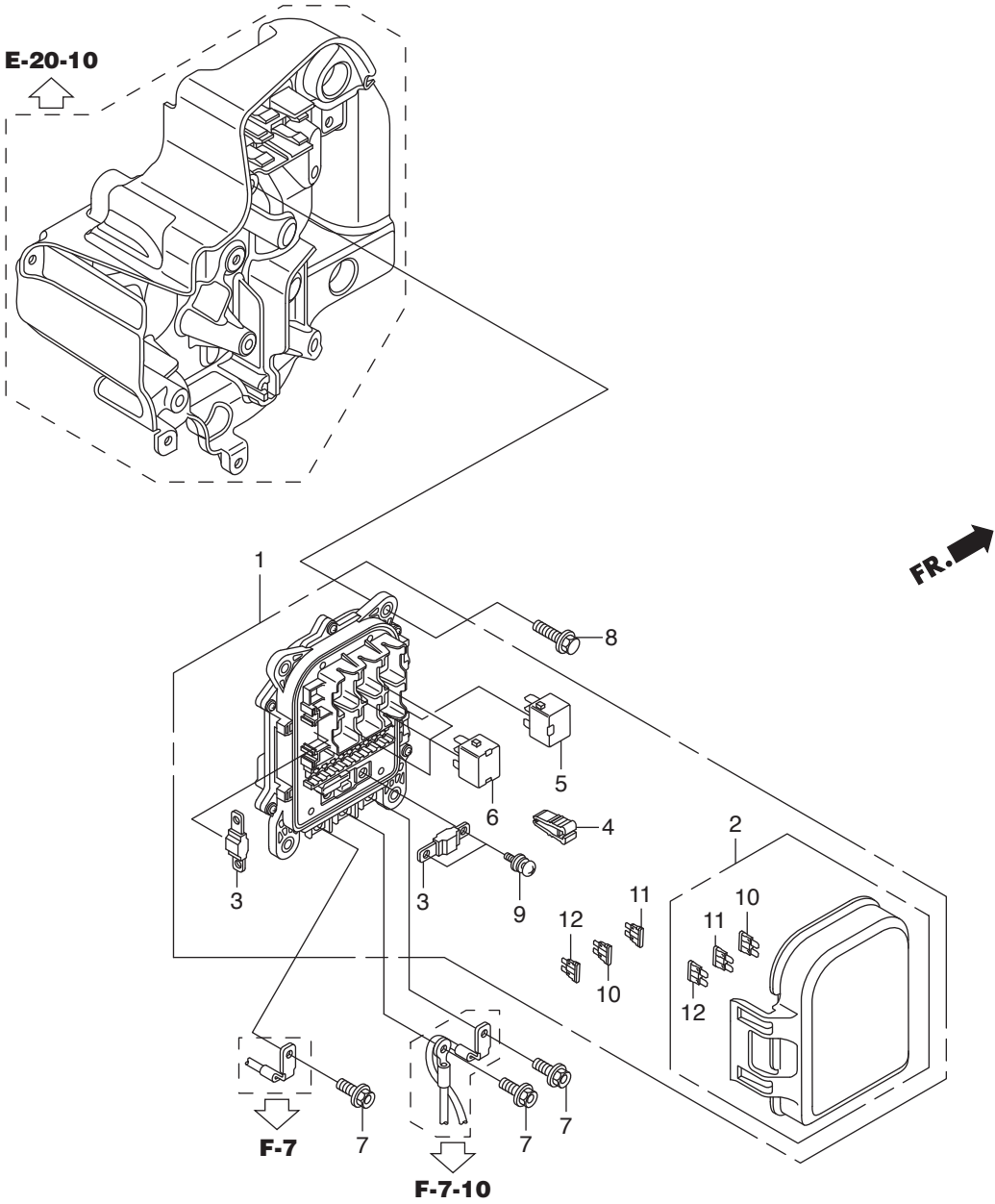



FR. 

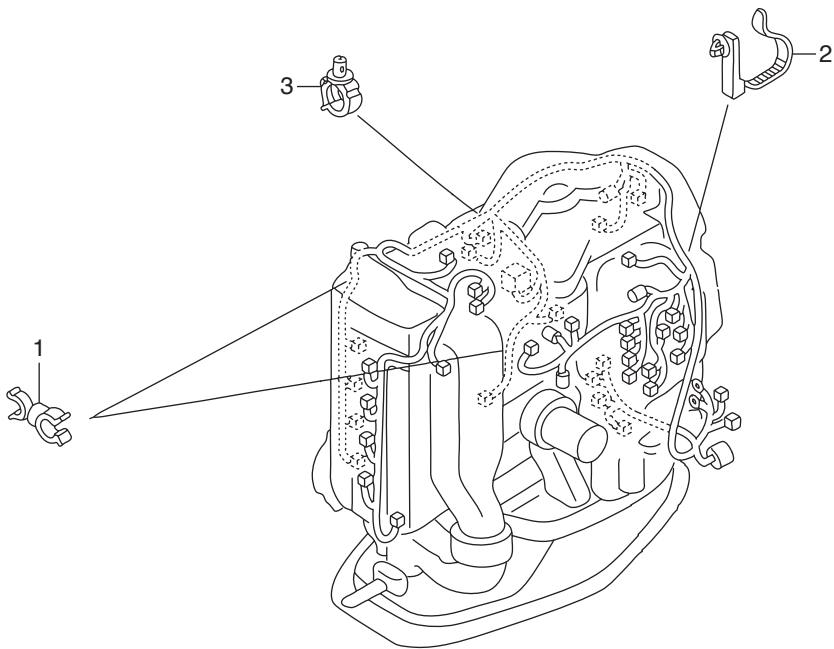



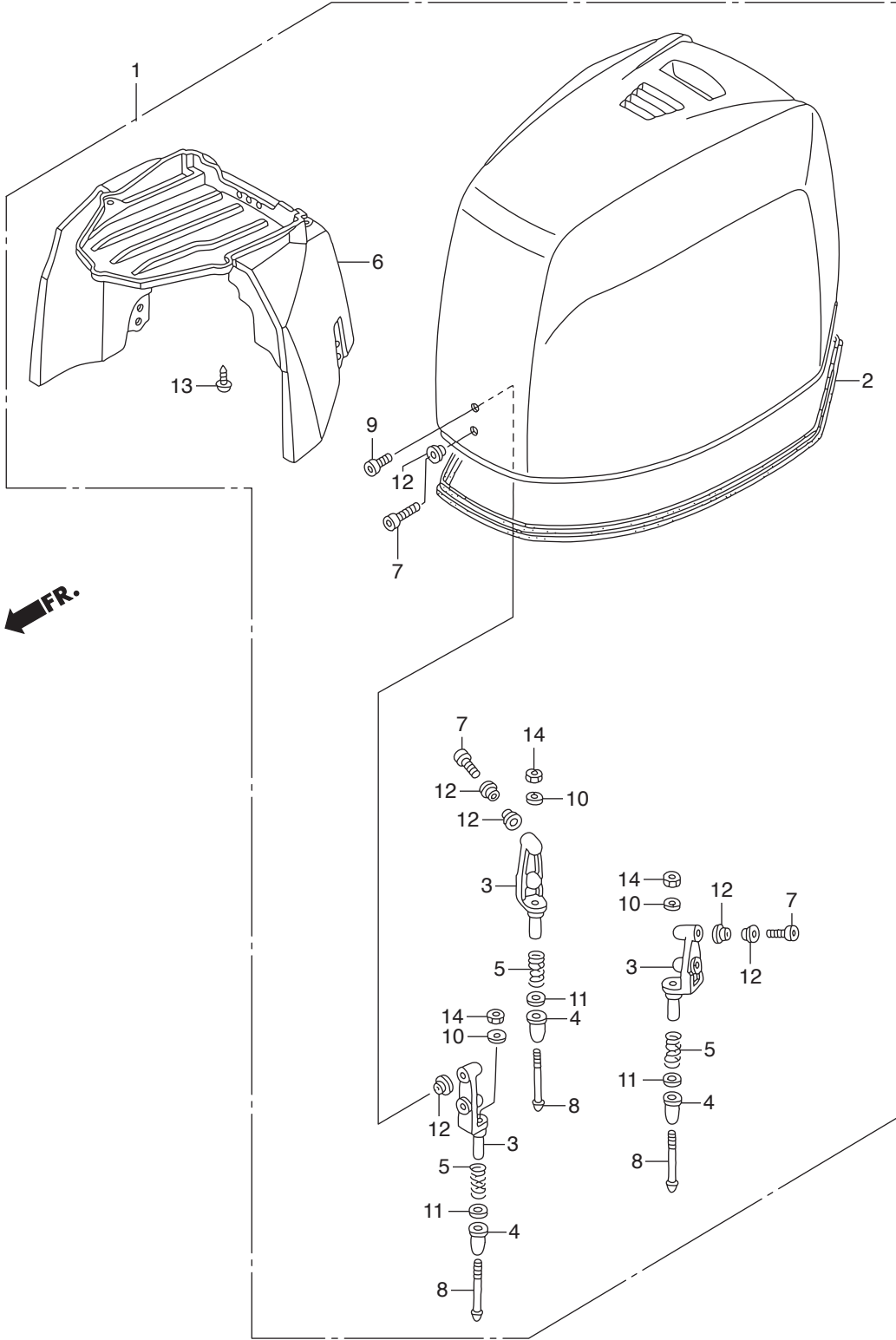



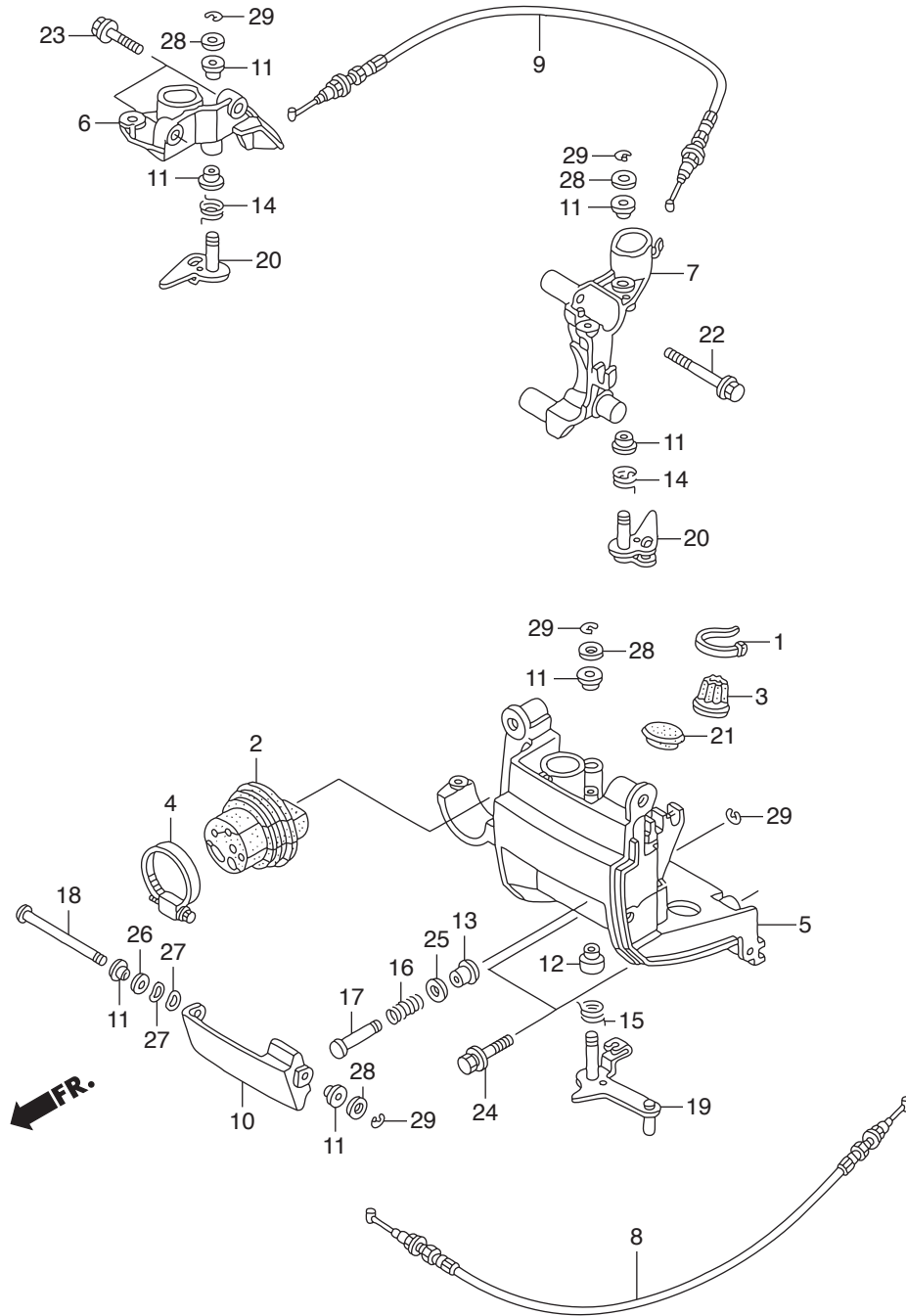



Ref.No.	Part No.	Description	Q' ty	Remarks	
			BFT150A		
F-8-10	1	HMG9-35701-950	BAND(BLACK 3.5X140)	1	
F-8-10	2	HZY6-40105-020	GROMMET, REMOTE CONTROL CABLE	1	
F-8-10	3	HZW1-40107-700	GROMMET, UNDER CASE(C)	1	
F-8-10	4	HZY3-40119-003	BAND, UNDER CASE GROMMET	1	
F-8-10	5	HZY6-40154-000ZC	BRACKET, FR. UNDER COVER	1	*T107* BAY BLUE
F-8-10	6	HZY6-40155-000	BRACKET, R. SIDE COVER	1	
F-8-10	7	HZY6-40157-000	BRACKET, L. SIDE COVER	1	
F-8-10	8	HZY6-60180-003	CABLE COMP. A, COVER LOCK	1	
F-8-10	9	HZY6-60185-003	CABLE COMP. B, COVER LOCK	1	
F-8-10	10	HZY3-63201-000ZC	LEVER, COVER LOCK	1	*T107* BAY BLUE
F-8-10	11	HZY3-63205-000	BUSH A, COVER LOCK	7	
F-8-10	12	HZY6-63205-000	BUSH A, COVER LOCK	1	
F-8-10	13	HZY3-63208-000	BUSH B, COVER LOCK	1	
F-8-10	14	HZY3-63212-000	SPRING, COVER LOCK HOOK	2	
F-8-10	15	HZY6-63212-000	SPRING, COVER LOCK HOOK	1	
F-8-10	16	HZY6-63223-000	SPRING, LOCK LEVER RETURN	1	
F-8-10	17	HZY3-63224-000	SHAFT, COVER OPEN	1	
F-8-10	18	HZY6-63225-000	SHAFT, FR. LOCK	1	
F-8-10	19	HZY6-63240-000	LOCK COMP., FR.	1	
F-8-10	20	HZY3-63260-000	LOCK COMP., SIDE	2	
F-8-10	21	HZC0-63515-700	CAP, L. SIDE COVER	1	
F-8-10	22	HZY6-90001-000	BOLT, FLANGE, 8X55	2	
F-8-10	23	HZY3-90030-000	BOLT, FLANGE, 6X22	2	
F-8-10	24	HZY6-90105-000	BOLT-WASHER, 8X30	2	
F-8-10	25	HMM8-90501-610	WASHER, PLAIN, 8MM	1	
F-8-10	26	HMM8-90502-610	WASHER, PLAIN, 10MM	1	
F-8-10	27	HZW9-90506-000	WASHER, WAVE, 10MM	2	
F-8-10	28	H921-90518-000	WASHER, PLAIN, 8MM	4	
F-8-10	29	HCO-94540-06029	E-RING, 6MM	5	

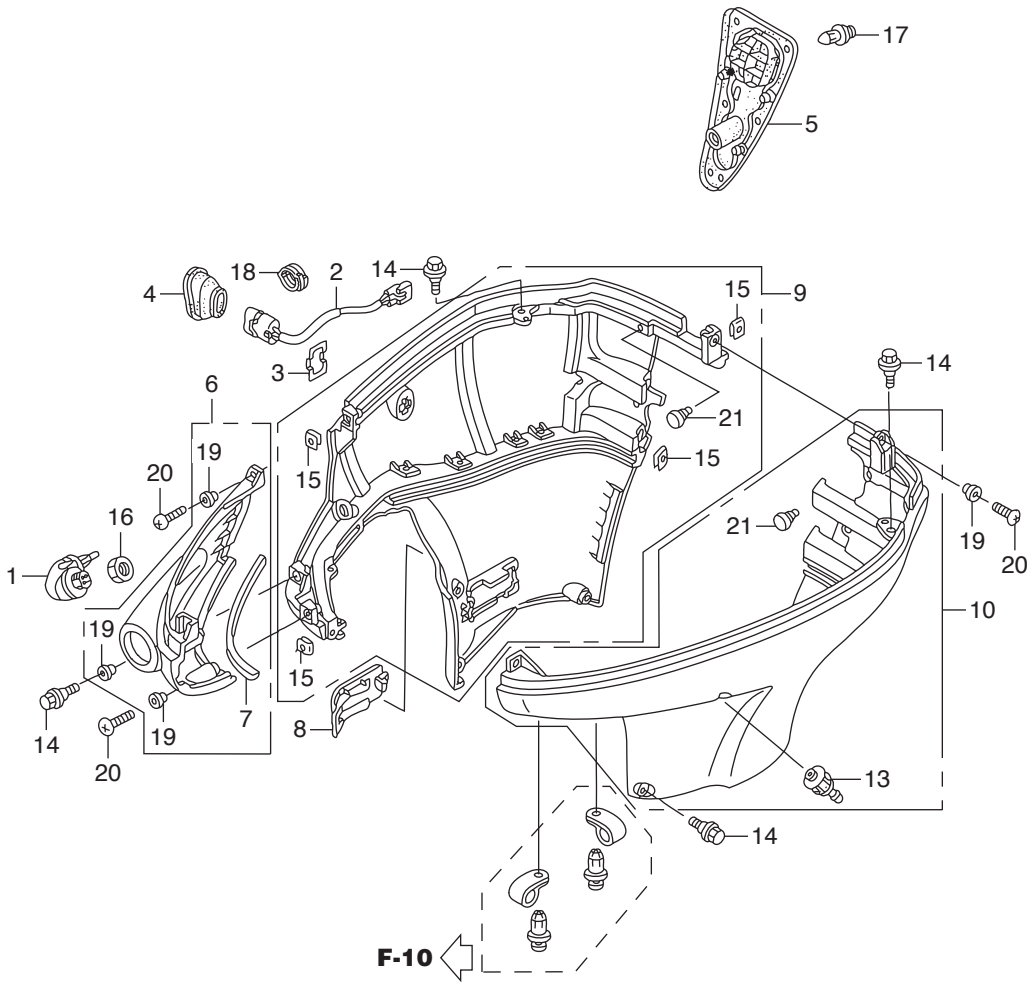

FR.

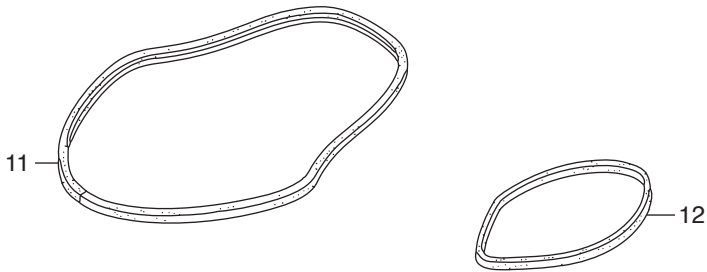

Ref.No.	Part No.	Description	Q' ty	Remarks	
			BFT150A		
F-8-20	1	HZY6-19289-000	CAP, WATER JOINT	1	
F-8-20	2	HZY6-35640-003	SWITCH ASSY., POWER TILT	1	
F-8-20	3	HZY3-35645-000	STAY, POWER TILT SWITCH	1	
F-8-20	4	HZY6-40114-010	GROMMET, POWER TILT SWITCH	1	
F-8-20	5	HZY6-40116-000	GROMMET, UNDER COVER	1	
F-8-20	6	HZY6-40151-010ZD	COVER, FR. SEPARATE	1	*T107* BAY BLUE
F-8-20	7	HZY6-40152-300	SEAL, FR. SEPARATE COVER	1	
F-8-20	8	HZY6-40212-020ZC	COVER, DRAIN PLUG	1	*T107* BAY BLUE
F-8-20	9	HZY6-63711-010ZC	COVER, R. ENGINE UNDER	1	*T107* BAY BLUE
F-8-20	10	HZY6-63716-010ZC	COVER, L. ENGINE UNDER	1	*T107* BAY BLUE
F-8-20	11	HZY6-63718-000	SEAL A, COVER UNDER	1	
F-8-20	12	HZY6-63719-000	SEAL B, COVER UNDER	1	
F-8-20	13	HZY6-82873-000	GROMMET, WATER CHECK	1	
F-8-20	14	HZY3-90111-000	BOLT, SPECIAL, 6X17	12	
F-8-20	15	HZY6-90301-000	NUT, CLIP	6	
F-8-20	16	H921-90302-000	NUT, HEX., 16MM	1	
F-8-20	17	HHC4-90653-900	CLIP, MUDGUARD	6	
F-8-20	18	HKJ2-90683-003	CLIP, WIRE HARNESS	1	
F-8-20	19	HZY6-91553-000	COLLAR, DISTANCE, 6.5X9X5	6	
F-8-20	20	HCO-93500-06025-4J	SCREW, PAN, 6X25	6	
F-8-20	21	HCO-95011-62000	RUBBER B, STAND STOPPER	2	

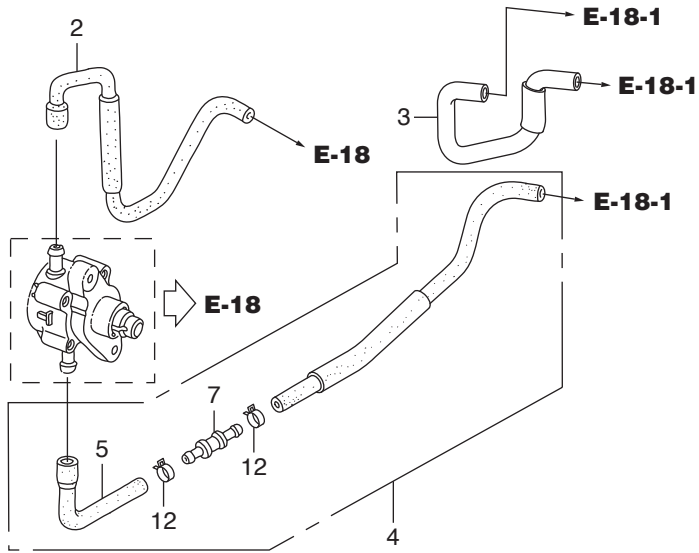

**FR.** →

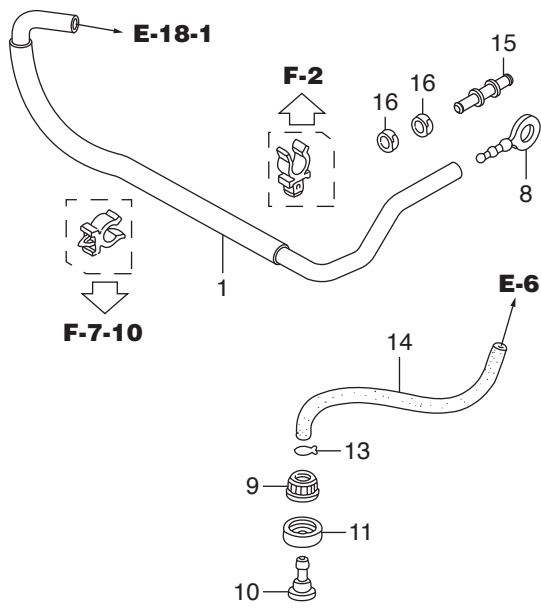



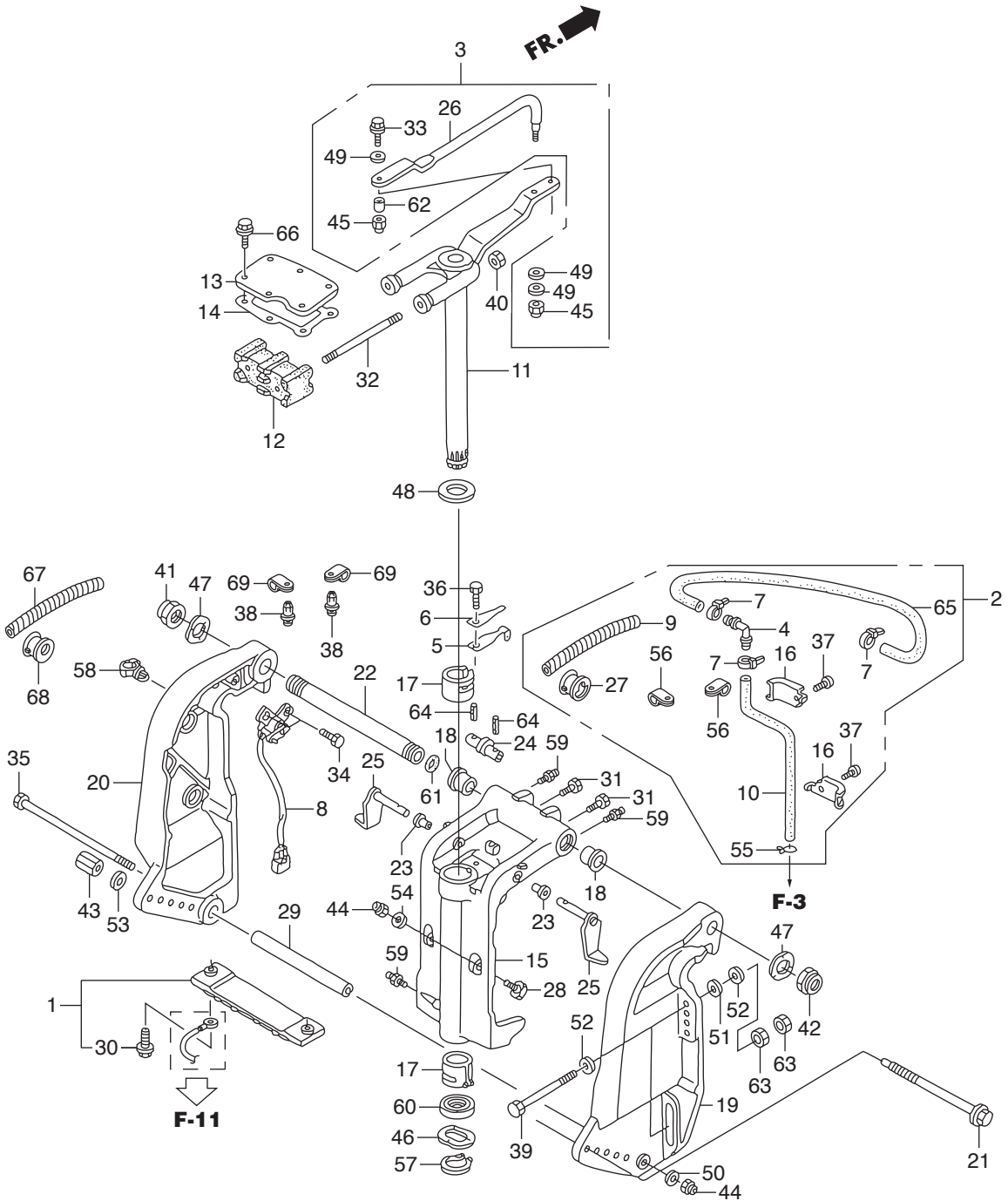

Ref.No.	Part No.	Description	Q' ty	Remarks	
			BFT150A		
F-10	1	HZW1-06411-020	METAL KIT, ANODE	1	
F-10	2	HZY6-06411-000	TUBE KIT, SPEED SENSOR	1	
F-10	3	HZY6-06532-U00	ROD KIT, STEERING	1	
F-10	4	HGE1-17357-670	JOINT A, BREATHER	1	
F-10	5	HZV1-24210-010	SPRING COMP., CLICK	1	
F-10	6	HZV4-24221-010	SPRING, CLICK ASSIST	1	
F-10	7	HKM3-32161-003	BAND, WIRE	3	
F-10	8	HZY6-35660-013	SENSOR ASSY., TRIM ANGLE	1	
F-10	9	HZY6-36104-003	TUBE, SPIRAL	1	
F-10	10	HZY6-41173-000	TUBE, SPEED SENSOR	1	
F-10	11	HZY6-50100-000	FRAME COMP., MOUNTING	1	
F-10	12	HZW5-50151-000	MOUNT COMP., UPPER RUBBER	1	
F-10	13	HZY6-50167-000	HOLDER, UPPER MOUNTING	1	
F-10	14	HZY6-50168-003	GASKET, UPPER MOUNTING HOLDER	1	
F-10	15	HZW1-50201-040ZC	CASE, SWIVEL	1	*T107* BAY BLUE
F-10	16	HZY6-50209-000	PLATE, SPEED SENSOR TUBE	2	
F-10	17	HZZ5-50211-000	LINER, SWIVEL CASE	2	
F-10	18	HZW1-50214-000	BUSH, SWIVEL CASE	2	
F-10	19	HZW1-50301-070ZC	BRACKET, R. STERN	1	*T107* BAY BLUE
F-10	20	HZW1-50311-070ZC	BRACKET, L. STERN	1	*T107* BAY BLUE
F-10	21	HZW5-50341-010	ROD, ADJUSTING	1	
F-10	22	HZY3-50381-000	SHAFT, TILTING	1	
F-10	23	HZV5-50522-000	BUSH, TILT ARM	2	
F-10	24	HZW1-50527-000	BRACKET, TILTING	1	
F-10	25	HZW1-50529-000	STOPPER, TILT	2	
F-10	26	HZW1-53238-010	ROD, STEERING	1	
F-10	27	HZY6-56118-000	BUSH, MOTOR CODE	1	
F-10	28	HZW1-56516-000	RECEIVER, THRUST	2	
F-10	29	HZW1-56539-000	COLLAR, LOWER CYLINDER	1	

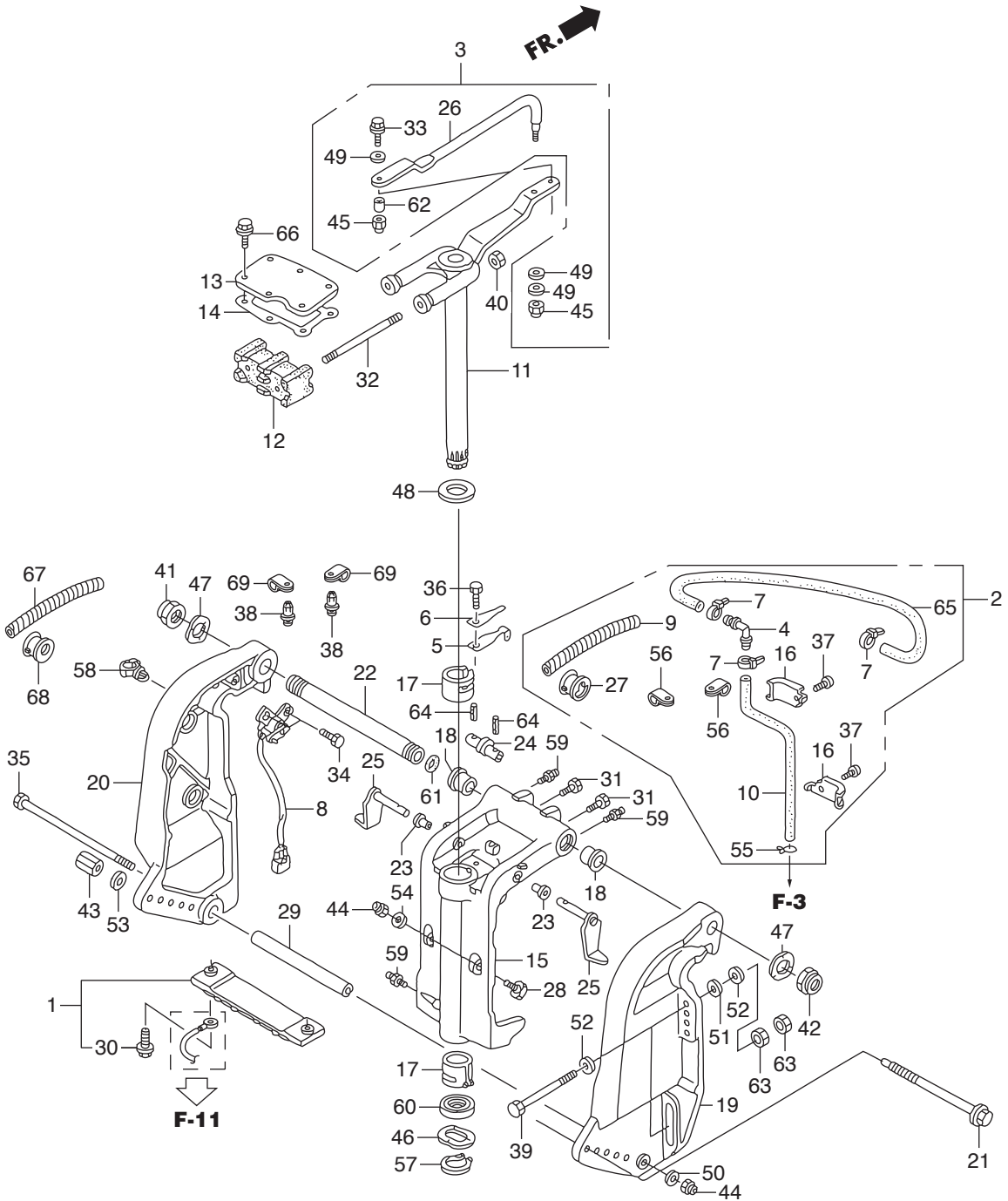



Ref.No.	Part No.	Description	Q' ty	Remarks	
			BFT150A		
F-10	30	HZW9-90009-000	BOLT, FLANGE, 6X23	2	
F-10	31	HZW1-90102-000	BOLT, 1/4-28UNF	2	
F-10	32	HZY6-90102-000	BOLT, STUD, 12X145	2	
F-10	33	HZW1-90105-000	BOLT, 3/8-24UNF	1	
F-10	34	HZW9-90105-000	BOLT, FLANGE, 6X20	2	
F-10	35	HZW1-90108-000	BOLT, HEX., 10X235	1	
F-10	36	H881-90110-000	BOLT, HEX., 6X14	1	
F-10	37	HZV5-90119-000	SCREW, PAN, 6X8	2	
F-10	38	HZV5-90127-003	SCREW, RIVET, 5X10	2	
F-10	39	HZX2-90129-000	BOLT, HEX., 12X130	4	
F-10	40	HZW5-90302-003	NUT, FLANGE, 12MM	2	
F-10	41	HZV5-90304-013	NUT, SELF-LOCK(7/8-14UNF)	1	
F-10	42	HZW1-90304-013	NUT, SELF-LOCK(25X2.0)	1	
F-10	43	HZW5-90304-000	NUT, ADJUSTER ROD	1	
F-10	44	HZW4-90306-003	NUT, FLANGE, 10MM	3	
F-10	45	HZV5-90307-003	NUT, SELF-LOCK(3/8-24UNF)	2	
F-10	46	HZV5-90501-000	WASHER, WAVE, 40MM	1	
F-10	47	HZV5-90502-000	WASHER, WAVE, 26MM	2	
F-10	48	HZV5-90504-000	WASHER, THRUST, 34MM	1	
F-10	49	HZV4-90514-000	WASHER, 10MM	3	
F-10	50	H921-90511-000	WASHER, PLAIN, 10MM	1	
F-10	51	HZV5-90552-000	WASHER, PLAIN, 12MM	4	
F-10	52	HZV5-90559-000	WASHER, PLAIN, 12MM	8	
F-10	53	HZV5-90559-000	WASHER, PLAIN, 12MM	1	
F-10	54	HZV5-90563-000	WASHER, PLAIN, 10MM	2	
F-10	55	H921-90602-000	CLIP, TUBE(B8)	1	
F-10	56	H750-90628-000	CLIP(14MM)	2	
F-10	57	HZV5-90651-000	CIRCLIP, EXTERNAL, 39MM	1	
F-10	58	H763-90681-A01	CLIP, WIRE HARNESS	1	

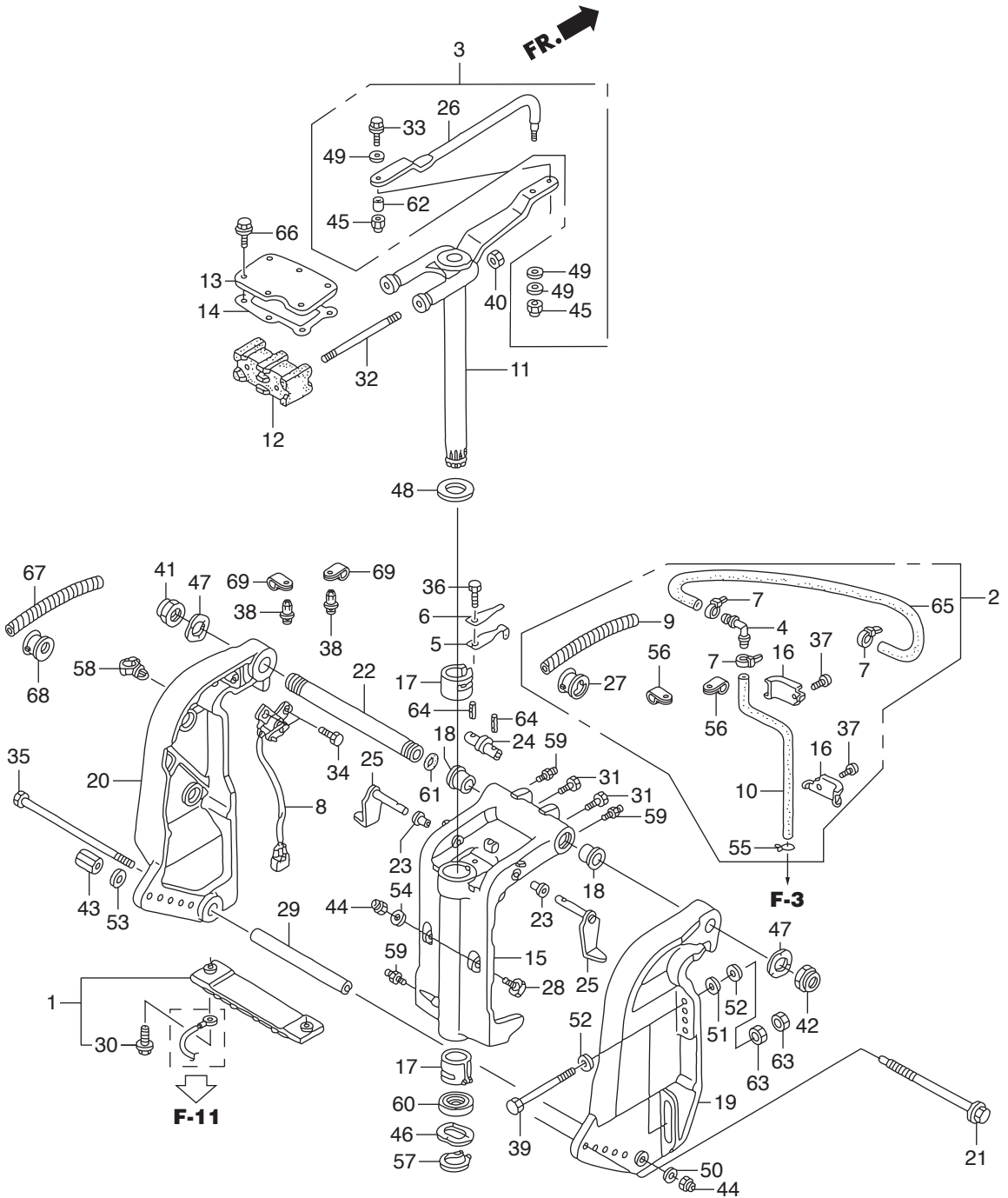



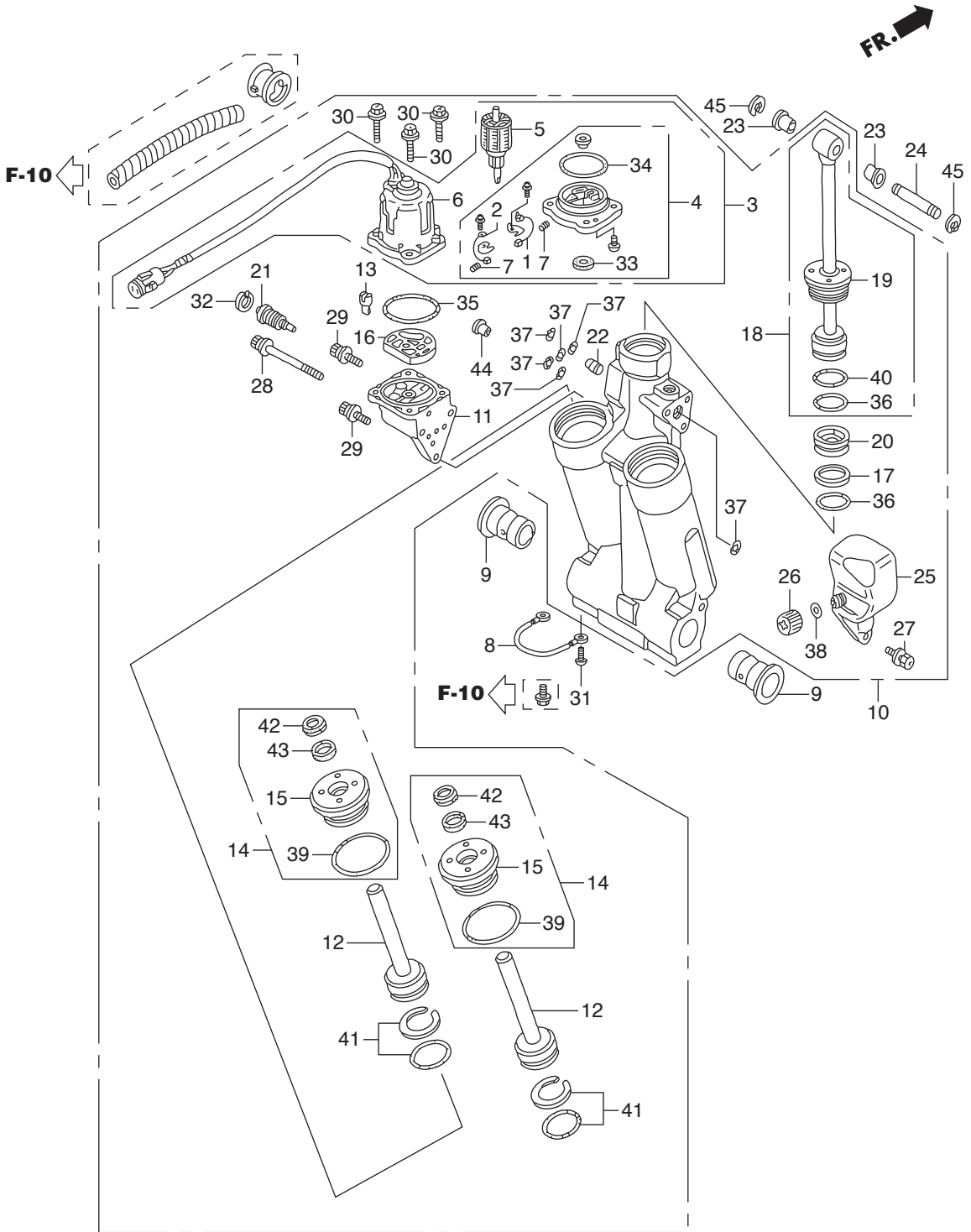

Ref.No.		Part No.	Description	Q' ty	Remarks
				BFT150A	
F-11	1	HZY3-30280-003	BREAKER ASSY.	1	
F-11	2	HZY3-31106-003	BRUSH ASSY.	1	
F-11	3	HZY6-36120-013	MOTOR ASSY., POWER TILT	1	
F-11	4	HZY3-36122-013	BRACKET ASSY.	1	
F-11	5	HZY3-36123-013	ARMATURE COMP.	1	
F-11	6	HZY6-36129-013	YOKE ASSY.	1	
F-11	7	HZV5-36136-821	SPRING, MOTOR	2	
F-11	8	HZY3-40219-013	WIRE, LEAD(1.5X116MM)	1	
F-11	9	HZV5-50214-003	BUSH, SWIVEL CASE	2	
F-11	10	HZY6-56000-043	TRIM-TILT ASSY., POWER	1	
F-11	11	HZY6-56100-013	PUMP ASSY.	1	
F-11	12	HZW1-56110-701	ROD COMP., PISTON(B)	2	
F-11	13	HZW1-56113-701	JOINT, DRIVE	1	
F-11	14	HZW1-56115-305	GUIDE COMP., ROD	2	
F-11	15	HZY9-56115-003	GUIDE COMP., ROD	2	
F-11	16	HZW1-56116-701	FILTER B	1	
F-11	17	HZV5-56117-821	RING, BACK UP	1	
F-11	18	HZW1-56120-305	ROD COMP., PISTON	1	
F-11	19	HZY9-56120-003	ROD COMP., PISTON	1	
F-11	20	HZW1-56130-702	PISTON COMP., FREE	1	
F-11	21	HZY3-56170-013	VALVE COMP., MANUAL	1	
F-11	22	HZW1-56180-701	VALVE COMP., RESERVOIR	1	
F-11	23	HZV5-56513-000	BUSH, LOWER CYLINDER	2	
F-11	24	HZW1-56532-000	PIN, UPPER CYLINDER	1	
F-11	25	HZW1-56851-703	TANK, OIL	1	
F-11	26	HZW1-56860-701	CAP COMP., OIL TANK	1	
F-11	27	HZW1-90113-702	BOLT, RECESSED	3	
F-11	28	HZW1-90114-702	BOLT, SOCKET(A)	1	
F-11	29	HZW1-90115-702	BOLT, SOCKET(B)	2	

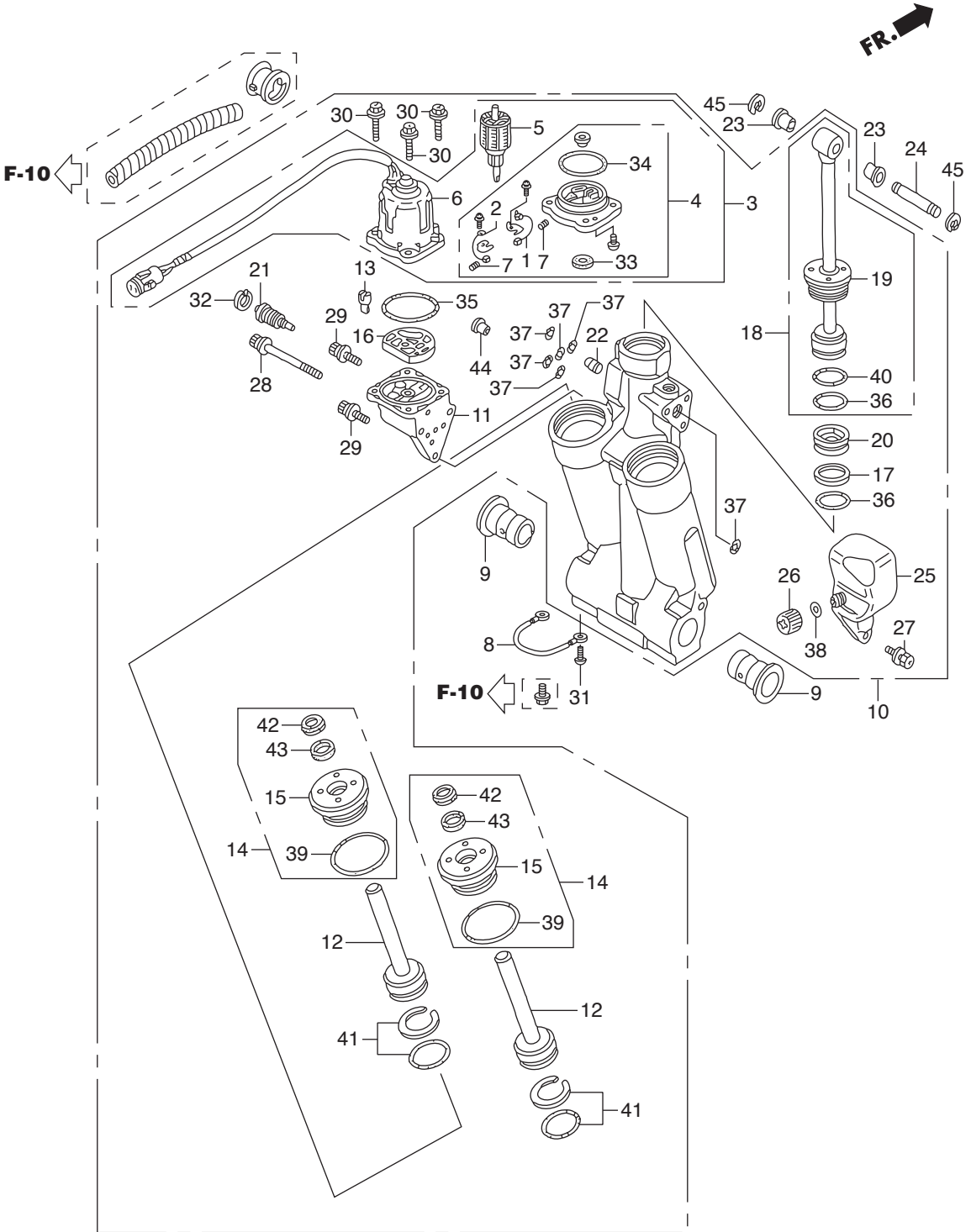



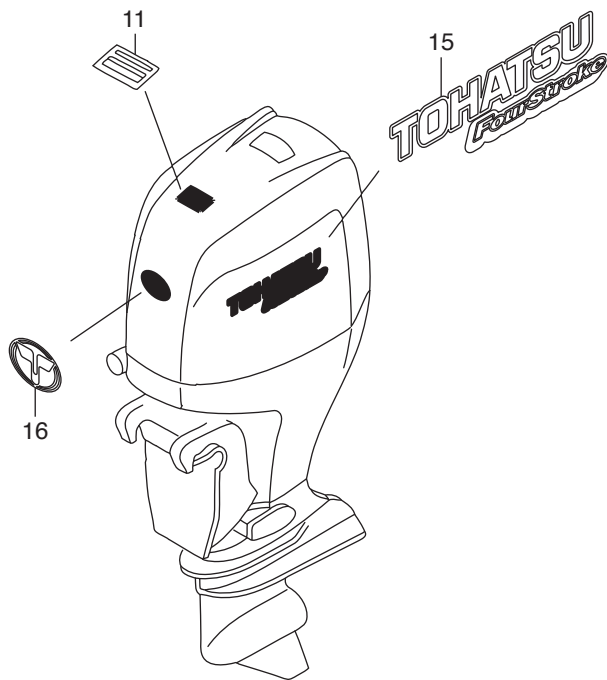
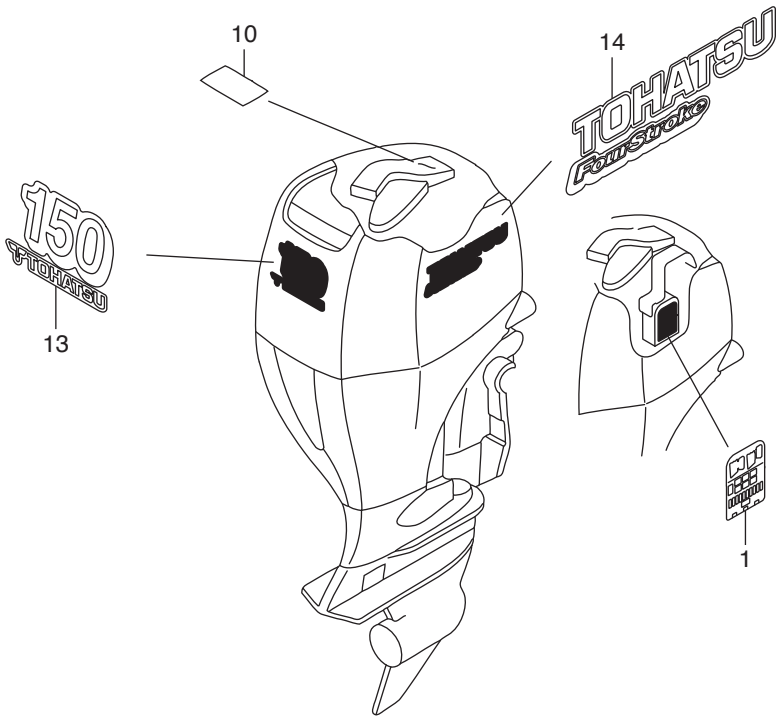





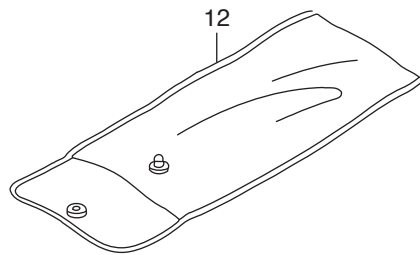
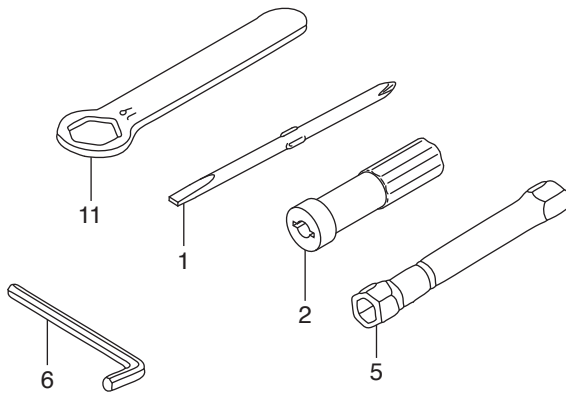



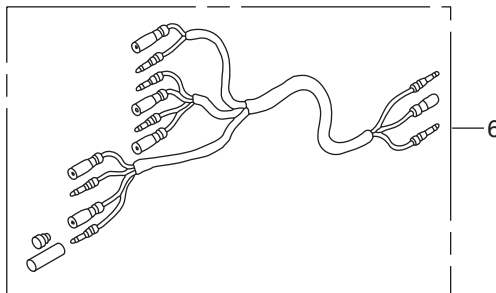
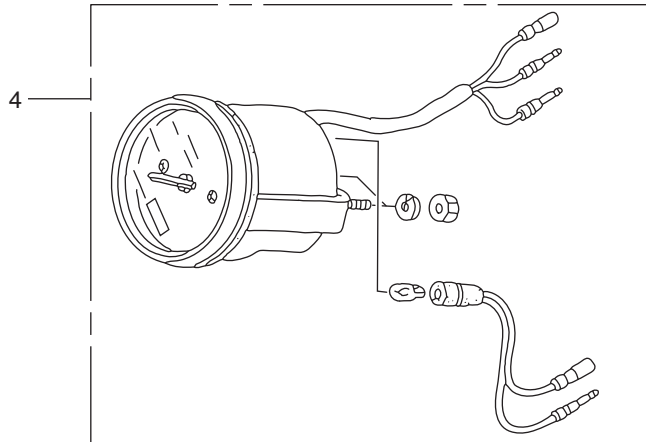
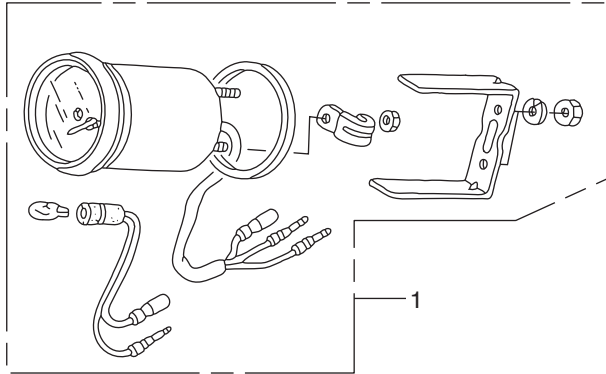



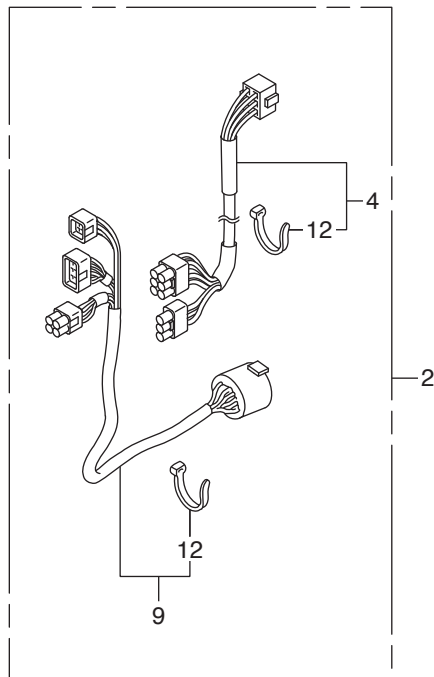
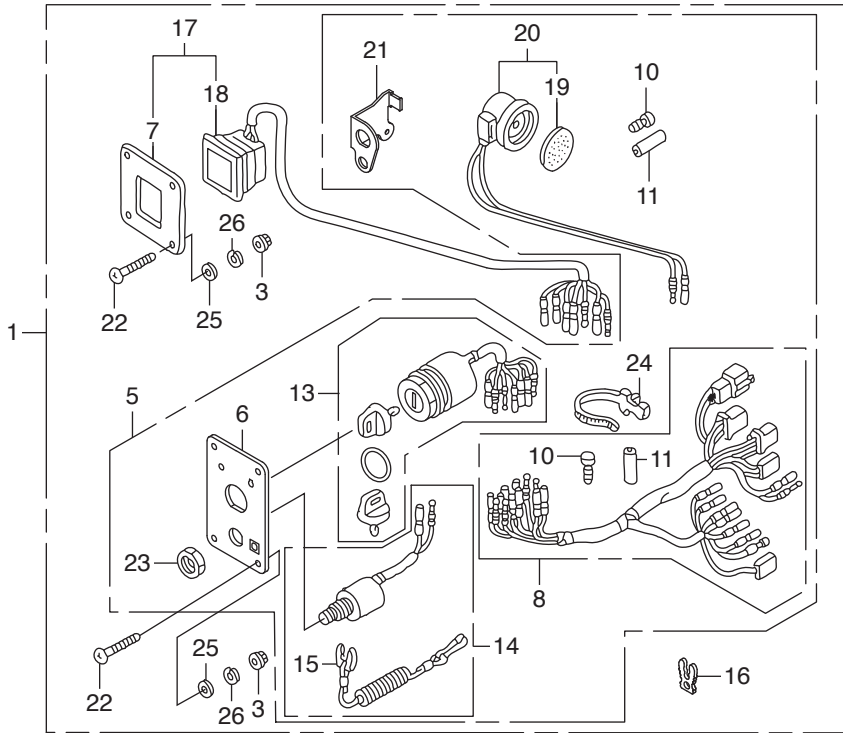

Ref.No.	Part No.	Description	Q' ty	Remarks	
			BFT150A		
FOP-6	1	HZZ3-06323-R20	PANEL KIT, SWITCH(B)(4-LED)	1	
FOP-6	2	HZZ5-06325-600	CABLE SET, PANEL INDICATOR	1	(20FT)
FOP-6		HZZ5-06325-700	CABLE SET, PANEL INDICATOR	1	(25FT)
FOP-6		HZZ5-06325-800	CABLE SET, PANEL INDICATOR	1	(30FT)
FOP-6	3	HMT8-18334-770	NUT, FLANGE, 5MM	8	
FOP-6	4	HZZ5-32185-600	CORD ASSY., INDICATOR(20FT)	1	
FOP-6		HZZ5-32185-700	CORD ASSY., INDICATOR(25FT)	1	
FOP-6		HZZ5-32185-800	CORD ASSY., INDICATOR(30FT)	1	
FOP-6	5	HZZ3-32341-R31	PANEL ASSY., SWITCH	1	
FOP-6	6	HZZ3-32346-R21	PANEL, CONTROL	1	
FOP-6	7	HZZ3-32347-R01	PANEL, CONTROL	1	
FOP-6	8	HZZ5-32545-000	HARNESS ASSY., SWITCH PANEL	1	
FOP-6	9	HZZ5-32580-600	CABLE ASSY., SWITCH PANEL	1	(20FT)
FOP-6		HZZ5-32580-700	CABLE ASSY., SWITCH PANEL	1	(25FT)
FOP-6		HZZ5-32580-800	CABLE ASSY., SWITCH PANEL	1	(30FT)
FOP-6	10	HZV5-32823-003	PLUG, INNER CONNECTOR	8	
FOP-6	11	HZV5-32824-003	PLUG, OUTER CONNECTOR	3	
FOP-6	12	H952-32901-770	TIE, CABLE(NATURAL)(2.4X92)	6	
FOP-6	13	HZZ3-35100-R11	SWITCH ASSY., COMBINATION	1	
FOP-6	14	HZV5-36180-033	SWITCH ASSY., EMERGENCY STOP	1	
FOP-6	15	HZV4-36182-651	CORD COMP., EMERGENCY	1	
FOP-6	16	HZV4-36187-652	CLIP, EMERGENCY LOCK	2	
FOP-6	17	HZZ3-37205-R01	PANEL ASSY., INDICATOR(4-LED)	1	
FOP-6	18	HZZ5-37210-762	LAMP ASSY., INDICATION(4-LED)	1	
FOP-6	19	H341-38403-672	PLATE, WINKER BUZZER	1	
FOP-6	20	HZV5-38410-003	BUZZER COMP., WARNING	1	
FOP-6	21	HZZ5-38414-003	BRACKET, BUZZER	1	
FOP-6	22	HZW5-90109-000	SCREW, PAN, 5X40	8	
FOP-6	23	H921-90302-000	NUT, HEX., 16MM	1	

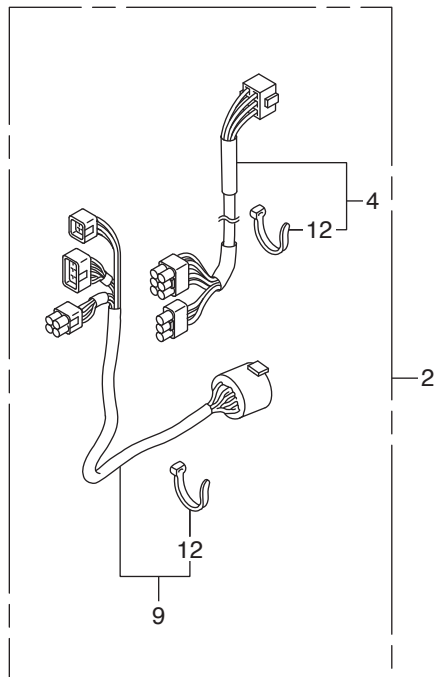
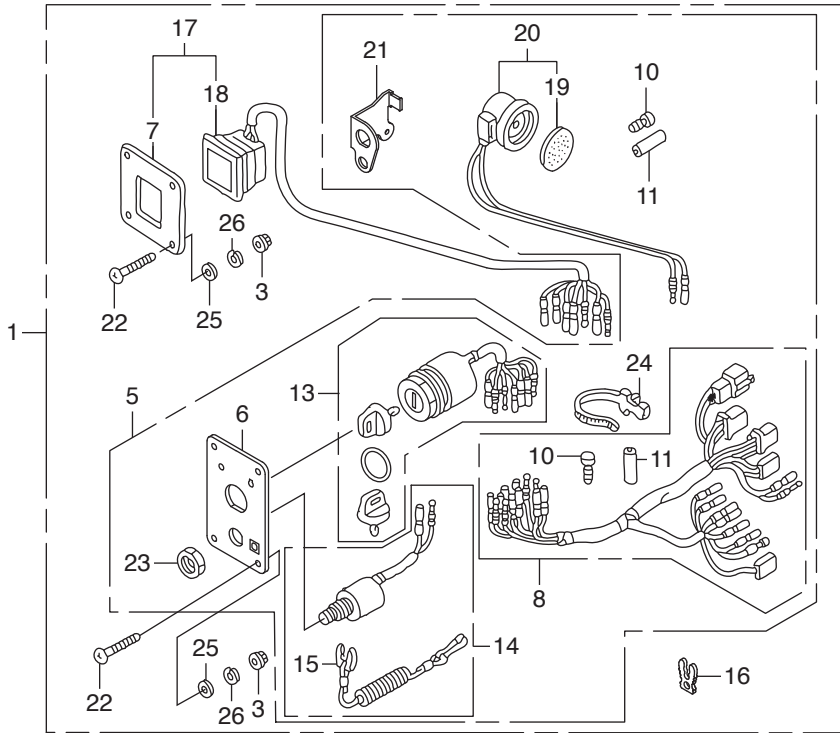





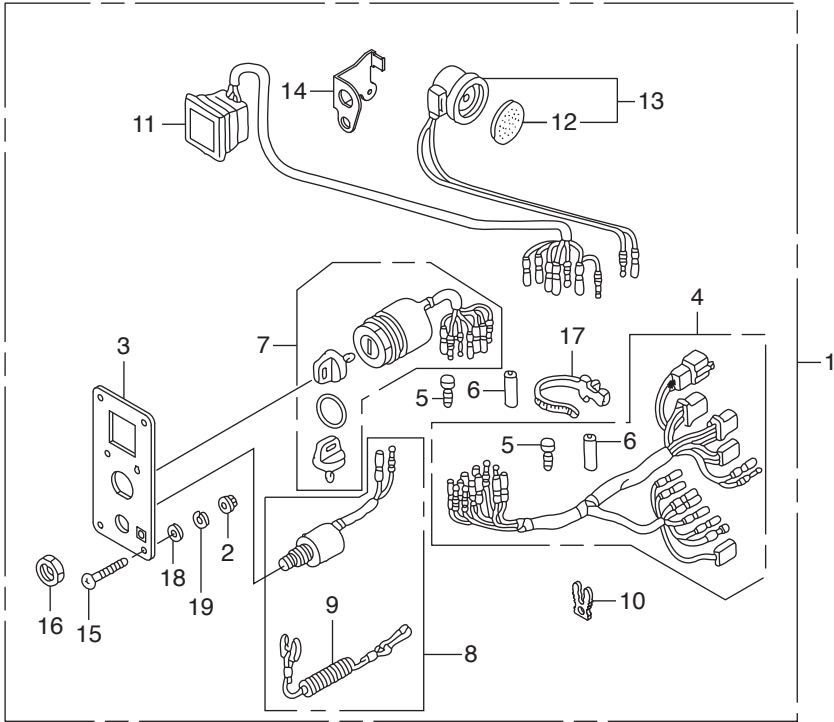



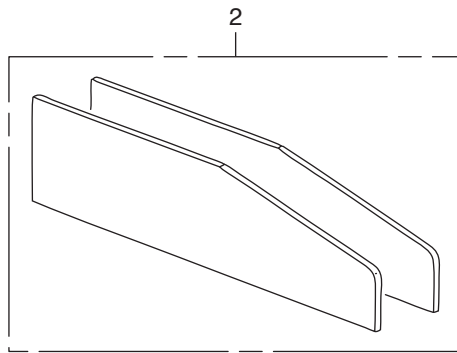
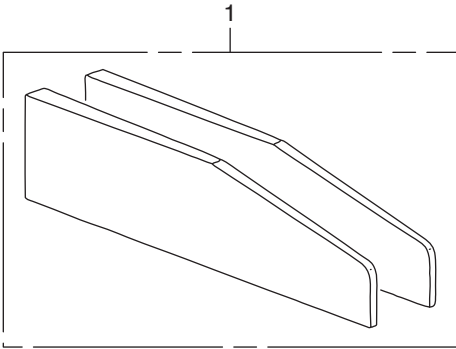





Ref.No.	Part No.	Description	Q' ty	Remarks	
			BFT150A		
FOP-8	1	HZZ3-06240-R30	BOX KIT, REMOTE CONTROL	1	(TOP MOUNT SINGLE)(R.)
FOP-8	2	HZW5-06241-U00	SPACER KIT, REMOTE CONTROL BOX	1	(TOP MOUNT SINGLE)
FOP-8	3	HZW5-24810-U01	HOUSING ASSY., L. INNER	1	(TOP MOUNT)
FOP-8	4	HZW5-24811-U01	HANDLE, REMOTE CONTROL	1	
FOP-8	5	HZW5-24812-U01	COVER, L. GRIP	1	
FOP-8	6	HZW5-24813-U01	GRIP, REMOTE CONTROL HANDLE	1	
FOP-8	7	HZW5-24814-U01	CAP, GRIP	1	
FOP-8	8	HZW5-24815-U01	CAP, SWITCH	1	
FOP-8	9	HZW5-24816-U01	BUTTON, THROTTLE	1	
FOP-8	10	HZW5-24817-U01	PLATE, HANDLE	1	
FOP-8	11	HZW5-24818-U01	PLATE, CABLE CLAMP	1	
FOP-8	12	HZW5-24819-U01	BRACKET, REMOTE CONTROL	2	HOUSING
FOP-8	13	HZZ3-24820-R11	HOUSING COMP., REMOTE CONTROL	1	BOX
FOP-8	14	HZW5-24825-U01	HOUSING, LEAD	1	
FOP-8	15	HZW5-24826-U01	PLATE, DWELL	1	
FOP-8	16	HZW5-24831-U01	TERMINAL, CABLE	2	
FOP-8	17	HZW5-24832-U01	SPACER, CABLE CLAMP	1	
FOP-8	18	HZW5-24834-U01	PACKING, SINGLE	1	
FOP-8	19	HZW7-32530-U00	SUB HARNESS ASSY., POWER	1	TRIM-TILT(A)
FOP-8	20	HZW5-35370-U02	SWITCH ASSY., POWER TRIM-TILT	1	(A)
FOP-8	21	HZZ3-87703-R81	MARK, REMOTE CONTROL(SINGLE)	1	
FOP-8	22	HZW5-90101-U00	SCREW, PAN, 5X16	2	
FOP-8	23	HZW5-90102-U00	SCREW, PAN, 5X10	1	
FOP-8	24	HZW5-90103-U01	SCREW, PAN, 5X20	2	
FOP-8	25	HZW5-90104-U00	SCREW, PAN, 5X18	4	
FOP-8	26	HZW5-90105-U01	SCREW, PAN, 4X10	2	
FOP-8	27	HZW5-90106-U00	SCREW, PAN, 6X18	2	
FOP-8	28	HZW5-90107-U00	SCREW, PAN, 5X40	4	
FOP-8	29	HZW5-90301-U00	NUT, HEX., 5MM	4	

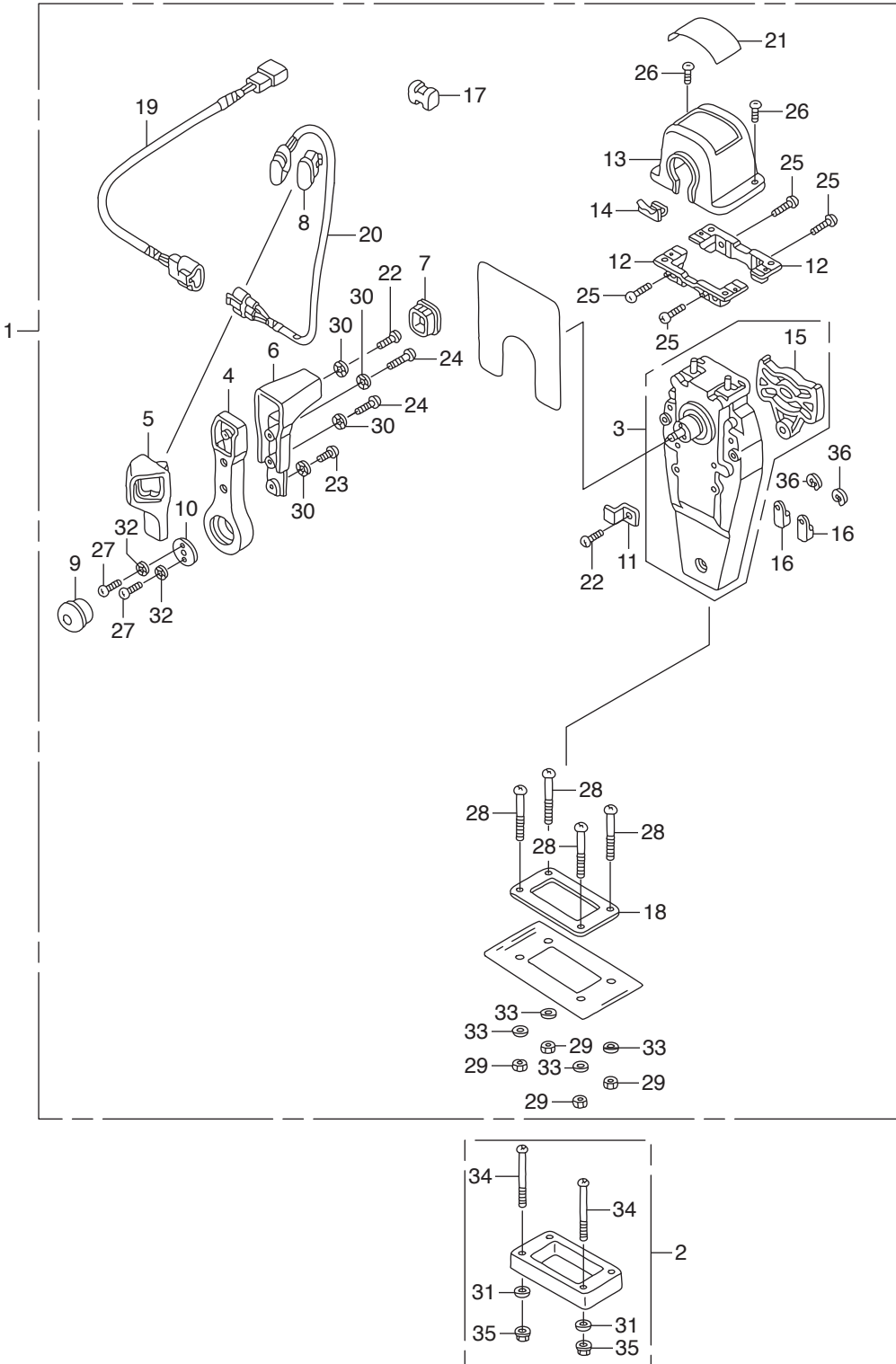





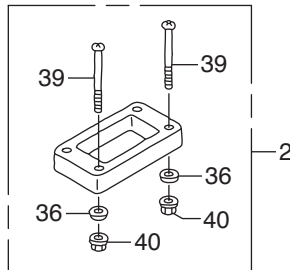
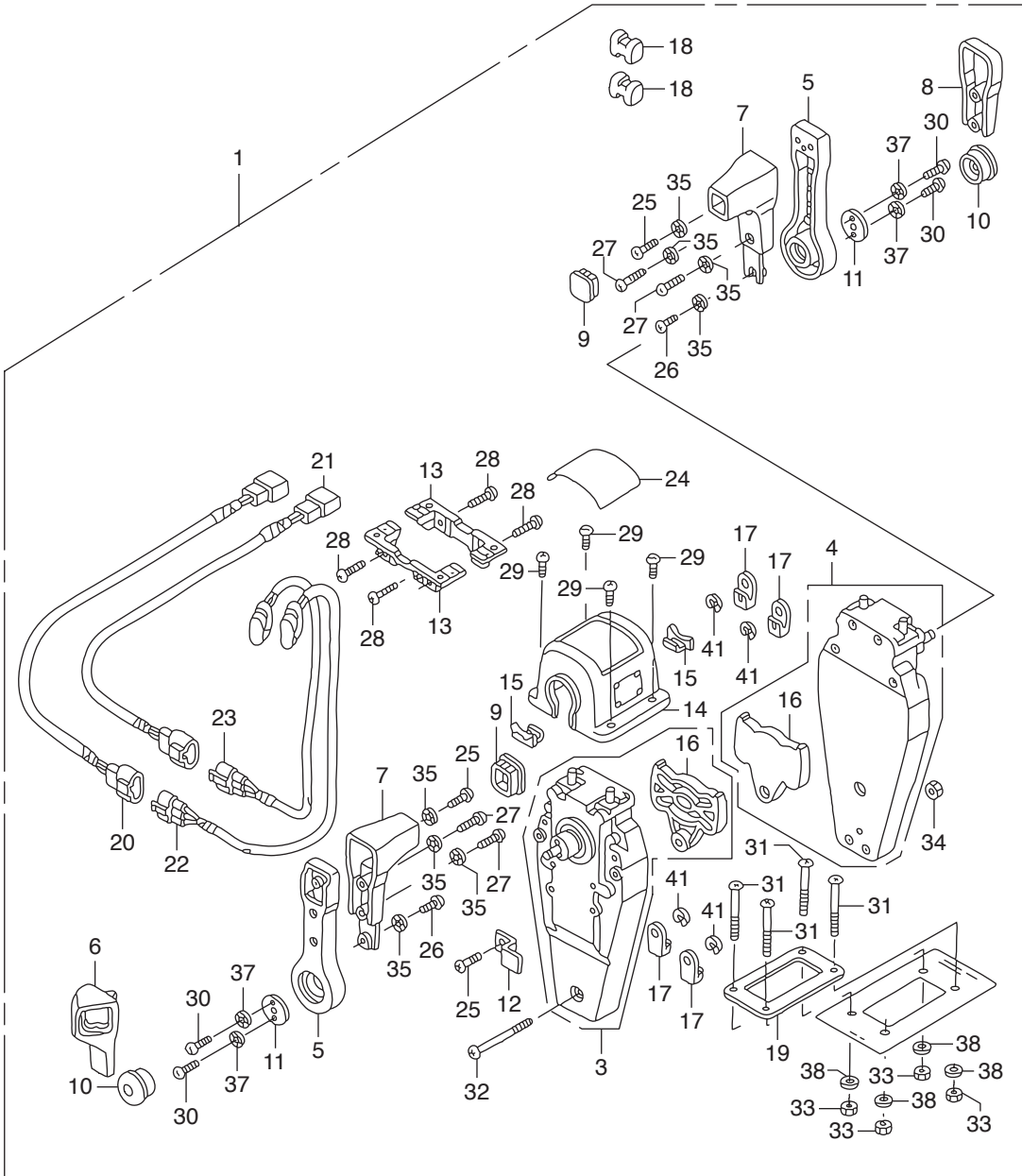

Ref.No.	Part No.	Description	Q' ty	Remarks	
			BFT150A		
FOP-8-2	1	HZZ3-06240-R60	BOX KIT, REMOTE CONTROL	1	(TOP MOUNT DUAL)(R.)
FOP-8-2	2	HZW5-06241-U10	SPACER KIT, REMOTE CONTROL BOX	1	(TOP MOUNT DUAL)
FOP-8-2	3	HZW5-24810-U01	HOUSING ASSY., L. INNER	1	(TOP MOUNT)
FOP-8-2	4	HZW5-24810-U11	HOUSING ASSY., R. INNER	1	(TOP MOUNT)
FOP-8-2	5	HZW5-24811-U01	HANDLE, REMOTE CONTROL	2	
FOP-8-2	6	HZW5-24812-U01	COVER, L. GRIP	1	
FOP-8-2	7	HZW5-24813-U01	GRIP, REMOTE CONTROL HANDLE	2	
FOP-8-2	8	HZW5-24813-U21	COVER, DUAL GRIP	1	
FOP-8-2	9	HZW5-24814-U01	CAP, GRIP	1	
FOP-8-2	10	HZW5-24816-U01	BUTTON, THROTTLE	2	
FOP-8-2	11	HZW5-24817-U01	PLATE, HANDLE	2	
FOP-8-2	12	HZW5-24818-U01	PLATE, CABLE CLAMP	1	
FOP-8-2	13	HZW5-24819-U01	BRACKET, REMOTE CONTROL	2	HOUSING
FOP-8-2	14	HZZ3-24820-R21	HOUSING COMP., REMOTE CONTROL	1	BOX(DUAL)
FOP-8-2	15	HZW5-24825-U01	HOUSING, LEAD	2	
FOP-8-2	16	HZW5-24826-U01	PLATE, DWELL	2	
FOP-8-2	17	HZW5-24831-U01	TERMINAL, CABLE	4	
FOP-8-2	18	HZW5-24832-U01	SPACER, CABLE CLAMP	2	
FOP-8-2	19	HZW5-24834-U21	PACKING, DUAL	1	
FOP-8-2	20	HZW7-32530-U00	SUB HARNESS ASSY., POWER	1	TRIM-TILT(A)
FOP-8-2	21	HZW7-32530-U10	SUB HARNESS ASSY., POWER	1	TRIM-TILT(B)
FOP-8-2	22	HZW5-35370-U02	SWITCH ASSY., POWER TRIM-TILT	1	(A)
FOP-8-2	23	HZW5-35370-U12	SWITCH ASSY., POWER TRIM-TILT	1	(B)
FOP-8-2	24	HZZ3-87703-R01	MARK, REMOTE CONTROL(DUAL)	1	
FOP-8-2	25	HZW5-90101-U00	SCREW, PAN, 5X16	3	
FOP-8-2	26	HZW5-90102-U00	SCREW, PAN, 5X10	2	
FOP-8-2	27	HZW5-90103-U01	SCREW, PAN, 5X20	4	
FOP-8-2	28	HZW5-90104-U00	SCREW, PAN, 5X18	4	
FOP-8-2	29	HZW5-90105-U01	SCREW, PAN, 4X10	4	

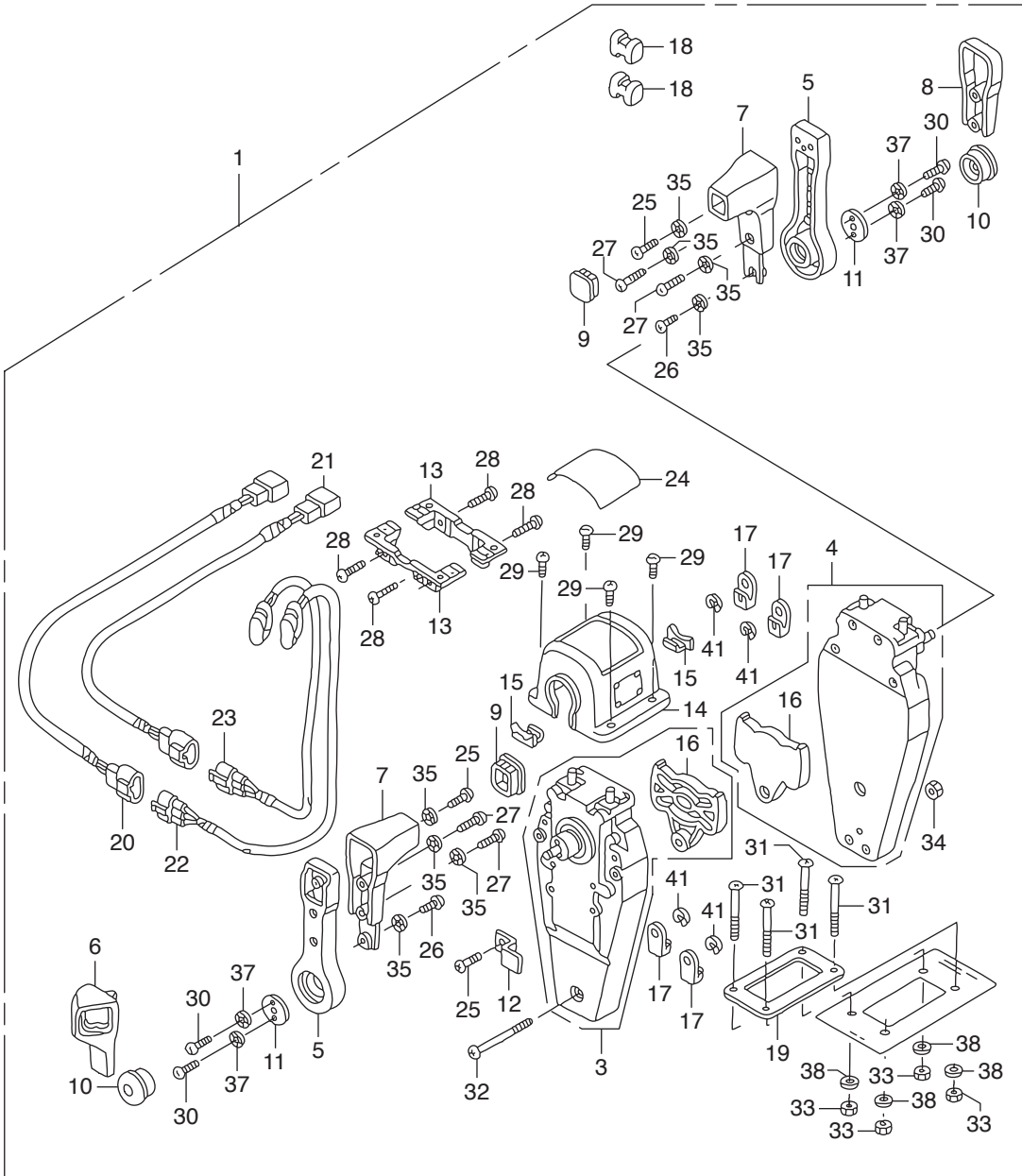



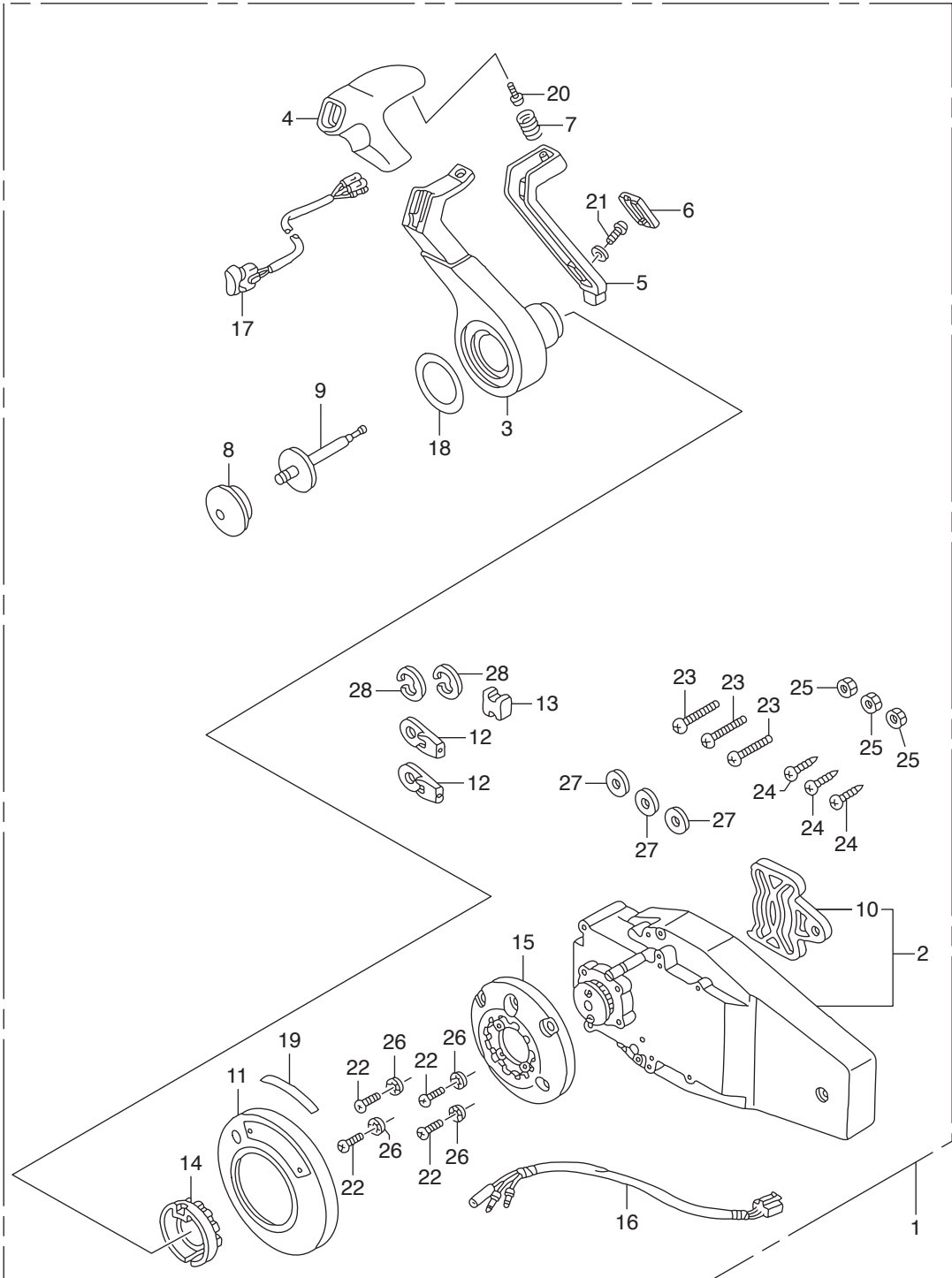

Ref.No.	Part No.	Description	Q' ty	Remarks	
			BFT150A		
FOP-8-4	1	HZZ3-06240-R40	BOX KIT, REMOTE CONTROL	1	(FLUSH MOUNT)(R.)
FOP-8-4	2	HZW7-24810-U01	HOUSING ASSY., R. INNER	1	(FLUSH MOUNT)
FOP-8-4	3	HZW7-24811-U01	HANDLE, REMOTE CONTROL	1	
FOP-8-4	4	HZW7-24812-U01	COVER, GRIP	1	
FOP-8-4	5	HZW7-24813-U01	ARM, NEUTRAL LOCK	1	
FOP-8-4	6	HZW7-24814-U01	COVER, LOCK ARM	1	
FOP-8-4	7	HZW7-24815-U01	SPRING, NEUTRAL LOCK ARM	1	
FOP-8-4	8	HZW5-24816-U01	BUTTON, THROTTLE	1	
FOP-8-4	9	HZW7-24817-U01	SHAFT, THROTTLE BUTTON	1	
FOP-8-4	10	HZW5-24826-U01	PLATE, DWELL	1	
FOP-8-4	11	HZZ3-24830-R41	COVER ASSY.	1	
FOP-8-4	12	HZW5-24831-U01	TERMINAL, CABLE	2	
FOP-8-4	13	HZW5-24832-U01	SPACER, CABLE CLAMP	1	
FOP-8-4	14	HZW7-24832-U01	HOLDER, NEUTRAL LOCK	1	
FOP-8-4	15	HZW7-24833-U01	BASE	1	
FOP-8-4	16	HZW7-32530-U20	SUB HARNESS ASSY., POWER	1	TRIM-TILT(C)
FOP-8-4	17	HZW7-35370-U02	SWITCH ASSY., POWER TRIM-TILT	1	(C)
FOP-8-4	18	HZZ3-87701-R40	MARK, HANDLE FLUSH MOUNT	1	
FOP-8-4	19	HZW7-87703-U00	MARK, FLUSH MOUNT	1	
FOP-8-4	20	HZW5-90101-U00	SCREW, PAN, 5X16	1	
FOP-8-4	21	HZW7-90101-U01	SCREW, TRUSS, 4X12	1	
FOP-8-4	22	HZW7-90102-U01	SCREW, PAN, 5X30	4	
FOP-8-4	23	HZW7-90103-U01	SCREW, PAN, 6X35	3	
FOP-8-4	24	HZW7-90104-U01	SCREW, TAPPING, 6X30	3	
FOP-8-4	25	HZW7-90301-U01	NUT, HEX., 6MM	3	
FOP-8-4	26	HZW5-90501-U00	WASHER, LOCK, 5MM	4	
FOP-8-4	27	HZW7-90502-U00	WASHER, PLAIN, 6MM	3	
FOP-8-4	28	HCO-94540-06029	E-RING, 6MM	2	

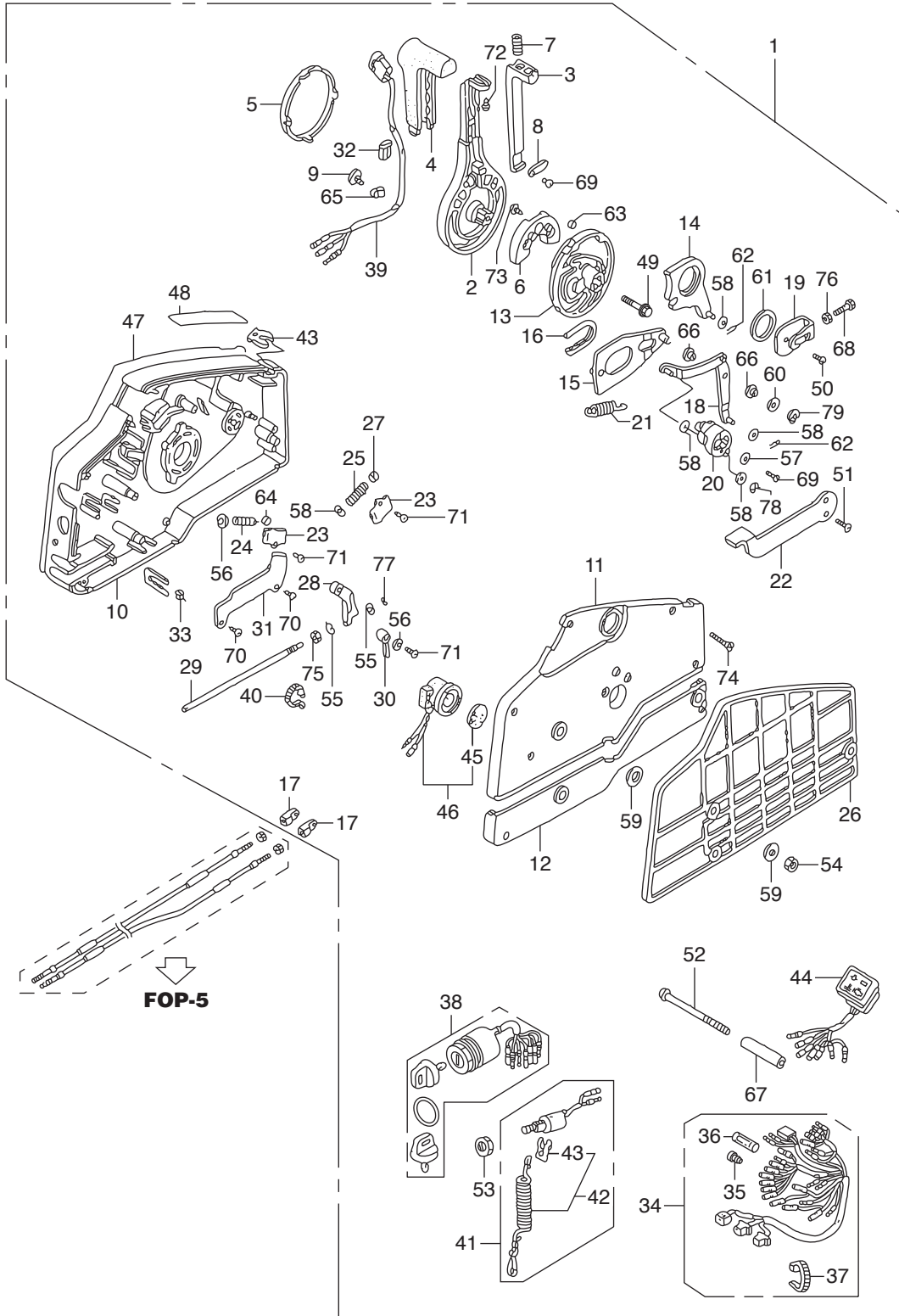



Ref.No.	Part No.	Description	Q' ty	Remarks	
			BFT150A		
FOP-8-6	1	HZZ3-24800-R00	BOX ASSY., REMOTE CONTROL(EU)	1	
FOP-8-6	2	HZV5-24811-010	HANDLE, REMOTE CONTROL	1	
FOP-8-6	3	HZV5-24812-000	LEVER, HANDLE LOCK	1	
FOP-8-6	4	HZV5-24813-000	GRIP, REMOTE CONTROL HANDLE	1	
FOP-8-6	5	HZV5-24814-010	CAP, HANDLE	1	
FOP-8-6	6	HZV5-24815-010	BLOCK, NEUTRAL LOCK	1	
FOP-8-6	7	HZV5-24816-000	SPRING, REMOTE CONTROL HANDLE	1	
FOP-8-6	8	HZV5-24817-000	PLATE, LEVER SETTING	1	
FOP-8-6	9	HZV5-24818-003	CLAMP, HARNESS	1	
FOP-8-6	10	HZV5-24820-010	HOUSING COMP., REMOTE CONTROL	1	BOX(A)
FOP-8-6	11	HZV5-24830-010	HOUSING COMP., REMOTE CONTROL	1	BOX(B)
FOP-8-6	12	HZV5-24836-000	HOUSING, REMOTE CONTROL BOX(C)	1	
FOP-8-6	13	HZV5-24841-000	WHEEL, CONTROL	1	
FOP-8-6	14	HZV5-24845-000	ARM COMP., SHIFT LINK	1	
FOP-8-6	15	HZV5-24850-000	PLATE COMP., SLIDING	1	
FOP-8-6	16	HZV5-24854-000	COLLAR, SLIDING PLATE	1	
FOP-8-6	17	HZV5-24855-000	PIVOT, SHIFT	2	
FOP-8-6	18	HZV5-24860-000	ARM COMP., LINK JOINT	1	
FOP-8-6	19	HZV5-24865-000	BRACKET, LINK JOINT	1	
FOP-8-6	20	HZV5-24875-000	WHEEL, ACCELERATOR	1	
FOP-8-6	21	HZV5-24876-000	SPRING, ACCELERATOR WHEEL	1	
FOP-8-6	22	HZV5-24878-000	LEVER, IDLE	1	
FOP-8-6	23	HZV5-24881-000	PLATE, SPRING SETTING	2	
FOP-8-6	24	HZV5-24883-000	SPRING, SHIFT CLICK	1	
FOP-8-6	25	HZV5-24884-000	SPRING, CHOKE RETURN	1	
FOP-8-6	26	HZV5-24885-000	SPACER, REMOTE CONTROL BOX	1	
FOP-8-6	27	HZV5-24887-000	SPACER, CLICK SPRING	1	
FOP-8-6	28	HZV5-24891-000	BLOCK, THROTTLE FRICTION	1	
FOP-8-6	29	HZV5-24892-000	BOLT, FRICTION	1	

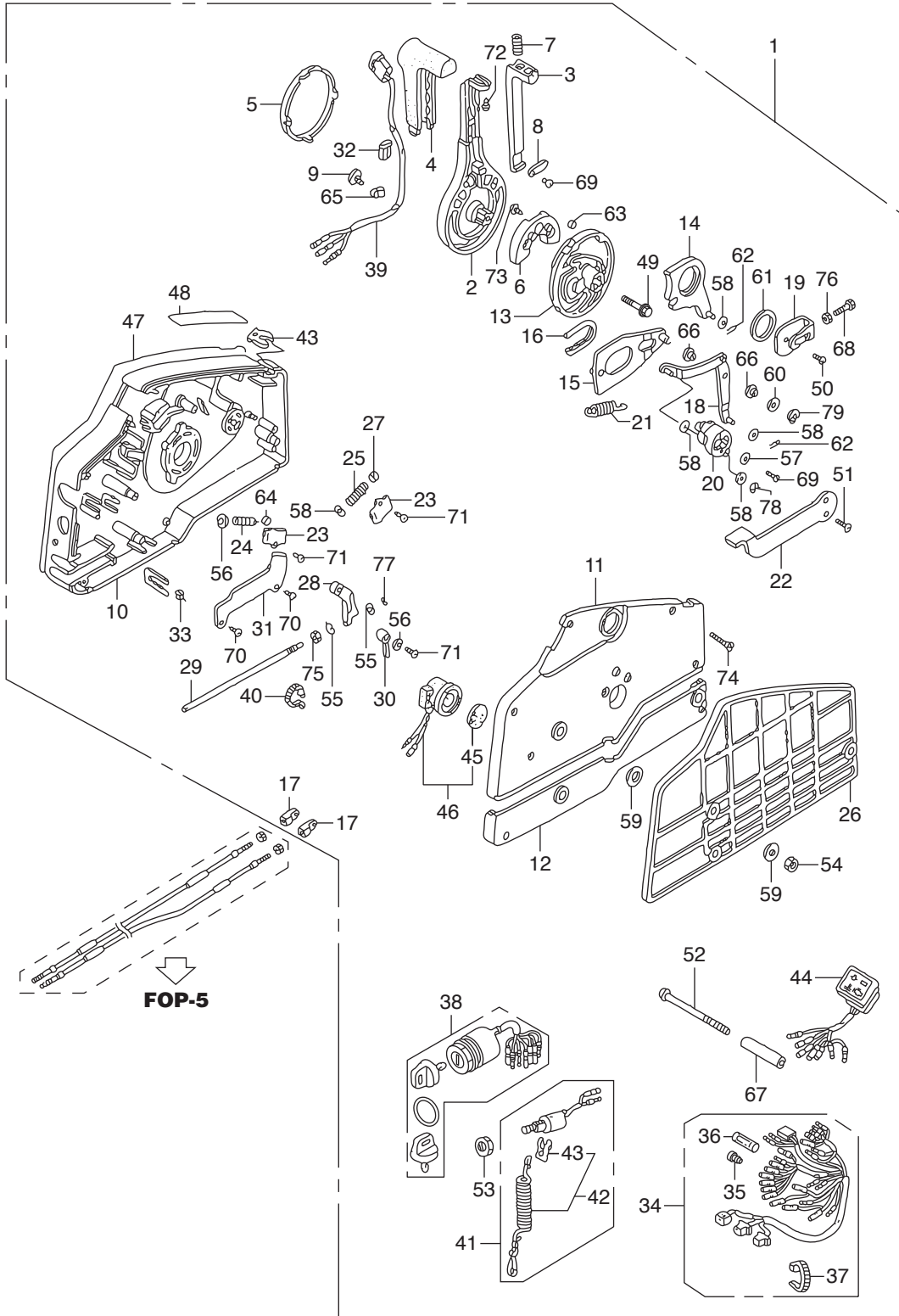

Ref.No.	Part No.	Description	Q' ty	Remarks	
			BFT150A		
FOP-8-6	30	HZV5-24894-000	SPACER, NEUTRAL SWITCH	1	
FOP-8-6	31	HZV5-24895-000	CLAMP, POWER TILT CORD	1	
FOP-8-6	32	HZV5-24897-000	PIPE, HARNESS GUIDE	1	
FOP-8-6	33	HZV5-24898-000	SPACER, CABLE CLAMP	1	
FOP-8-6	34	HZZ5-32530-000	CABLE ASSY., REMOTE CONTROL(B)	1	
FOP-8-6	35	HZV5-32823-003	PLUG, INNER CONNECTOR	7	
FOP-8-6	36	HZV5-32824-003	PLUG, OUTER CONNECTOR	1	
FOP-8-6	37	H952-32901-770	TIE, CABLE(NATURAL)(2.4X92)	1	
FOP-8-6	38	HZZ3-35100-R11	SWITCH ASSY., COMBINATION	1	
FOP-8-6	39	HZV5-35370-823	SWITCH ASSY., POWER TRIM-TILT	1	
FOP-8-6	40	HMG9-35701-950	BAND(BLACK 3.5X140)	1	
FOP-8-6	41	HZV5-36180-033	SWITCH ASSY., EMERGENCY STOP	1	
FOP-8-6	42	HZV4-36182-651	CORD COMP., EMERGENCY	1	
FOP-8-6	43	HZV4-36187-652	CLIP, EMERGENCY LOCK	2	
FOP-8-6	44	HZZ5-37210-013	LAMP ASSY., INDICATION	1	
FOP-8-6	45	H341-38403-672	PLATE, WINKER BUZZER	1	
FOP-8-6	46	HZV5-38410-003	BUZZER COMP., WARNING	1	
FOP-8-6	47	HZZ3-87701-R00	PLATE, REMOTE CONTROL	1	
FOP-8-6	48	HZW9-87702-800	MARK, FAST IDLE	1	
FOP-8-6	49	HZW9-90008-000	BOLT, FLANGE, 8X35	1	
FOP-8-6	50	HMM4-90105-000	SCREW, PAN, 6X10	1	
FOP-8-6	51	HZW4-90108-000	SCREW, FLAT, 5X12	2	
FOP-8-6	52	HZV5-90125-000	SCREW, 6X95	3	
FOP-8-6	53	H921-90302-000	NUT, HEX., 16MM	1	
FOP-8-6	54	HZV4-90304-000	NUT, HEX., 6MM	3	
FOP-8-6	55	HZW4-90401-000	WASHER, PLAIN, 4MM	2	
FOP-8-6	56	HZW4-90402-000	WASHER, PLAIN, 5MM	2	
FOP-8-6	57	HZV4-90502-000	WASHER, PLAIN, 5MM	1	
FOP-8-6	58	H921-90504-010	WASHER, PLAIN, 6MM	5	

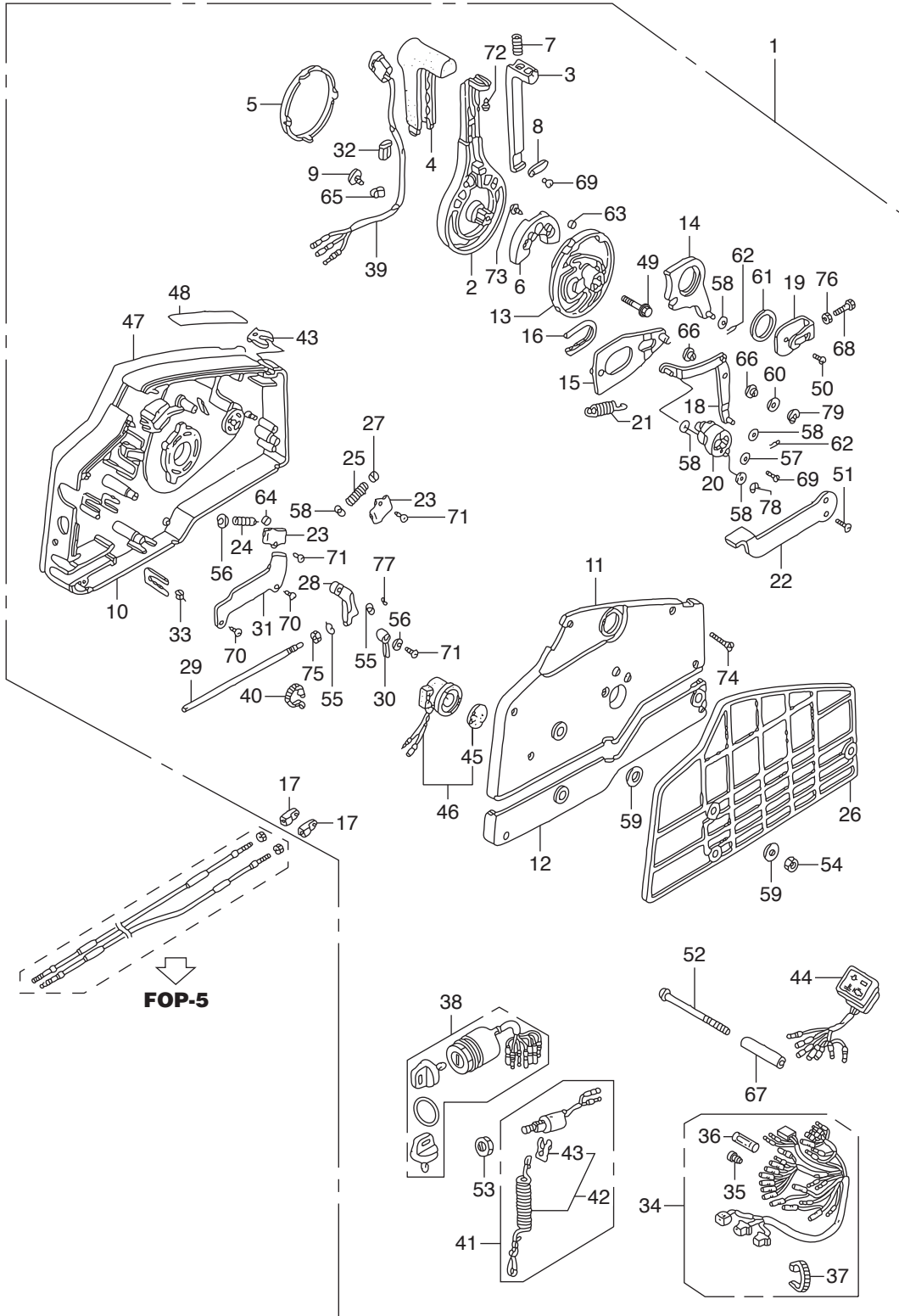



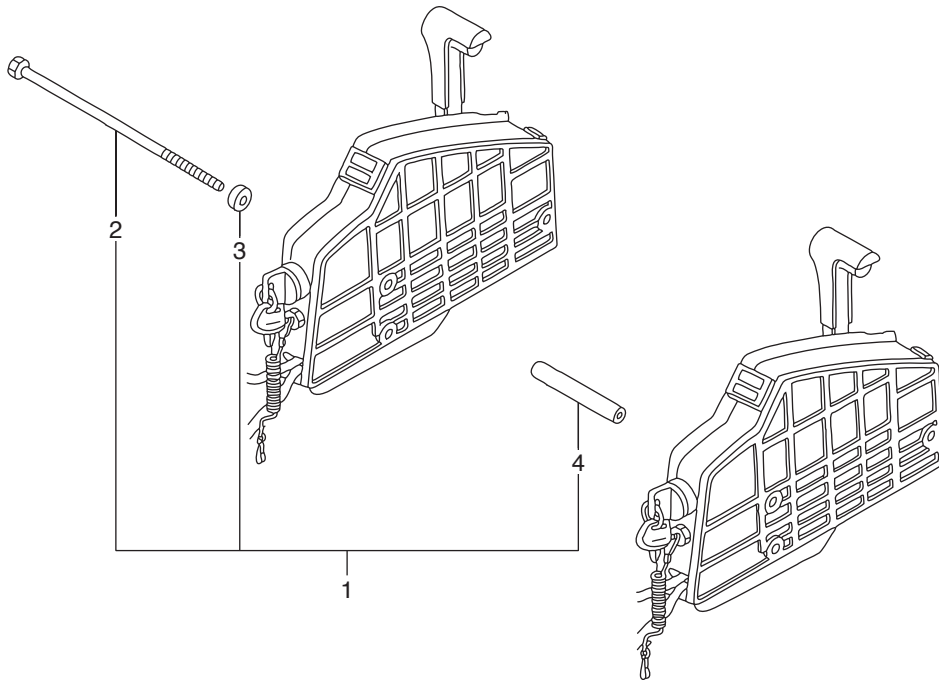



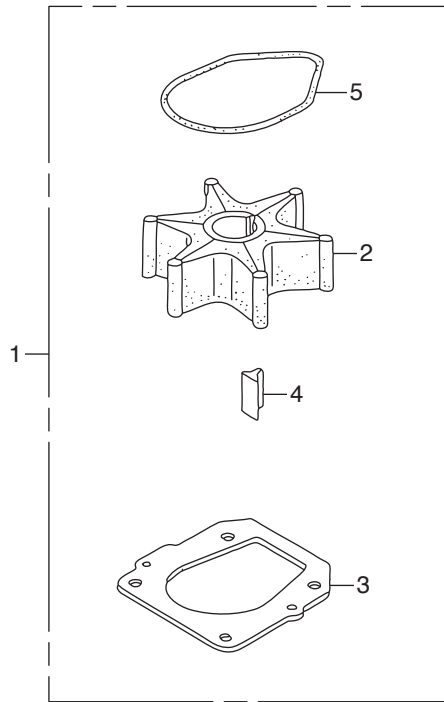





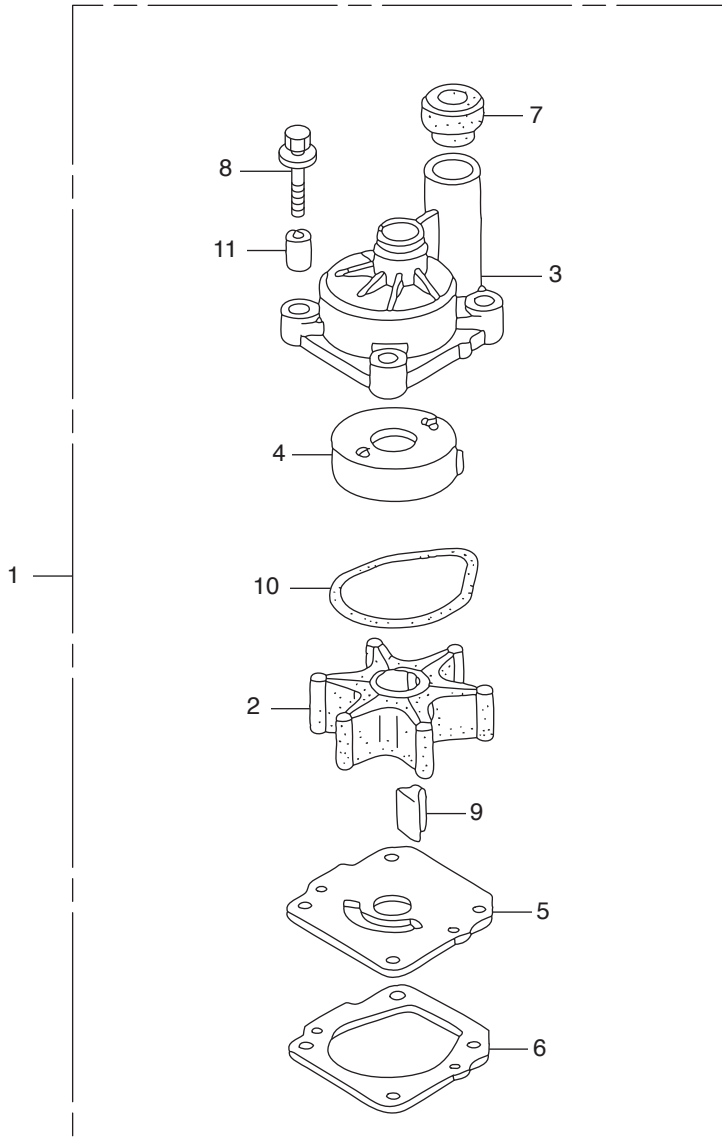



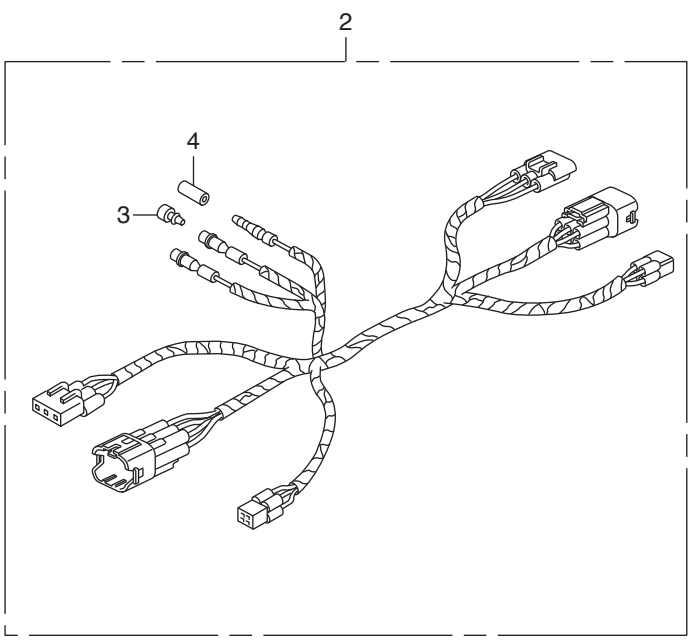
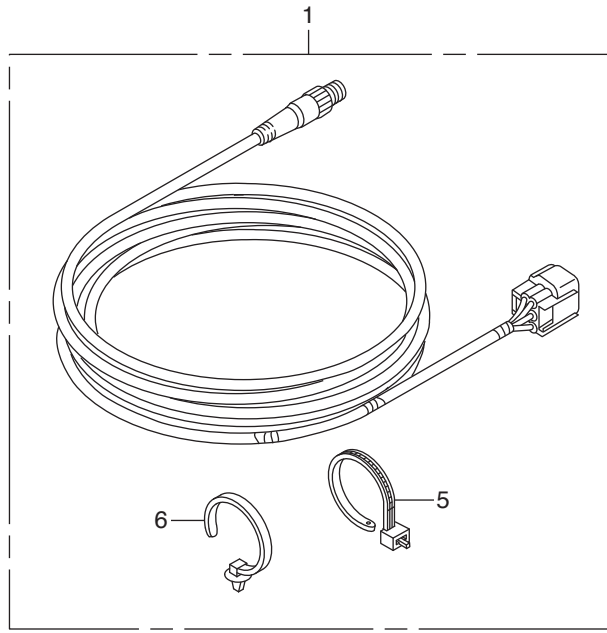



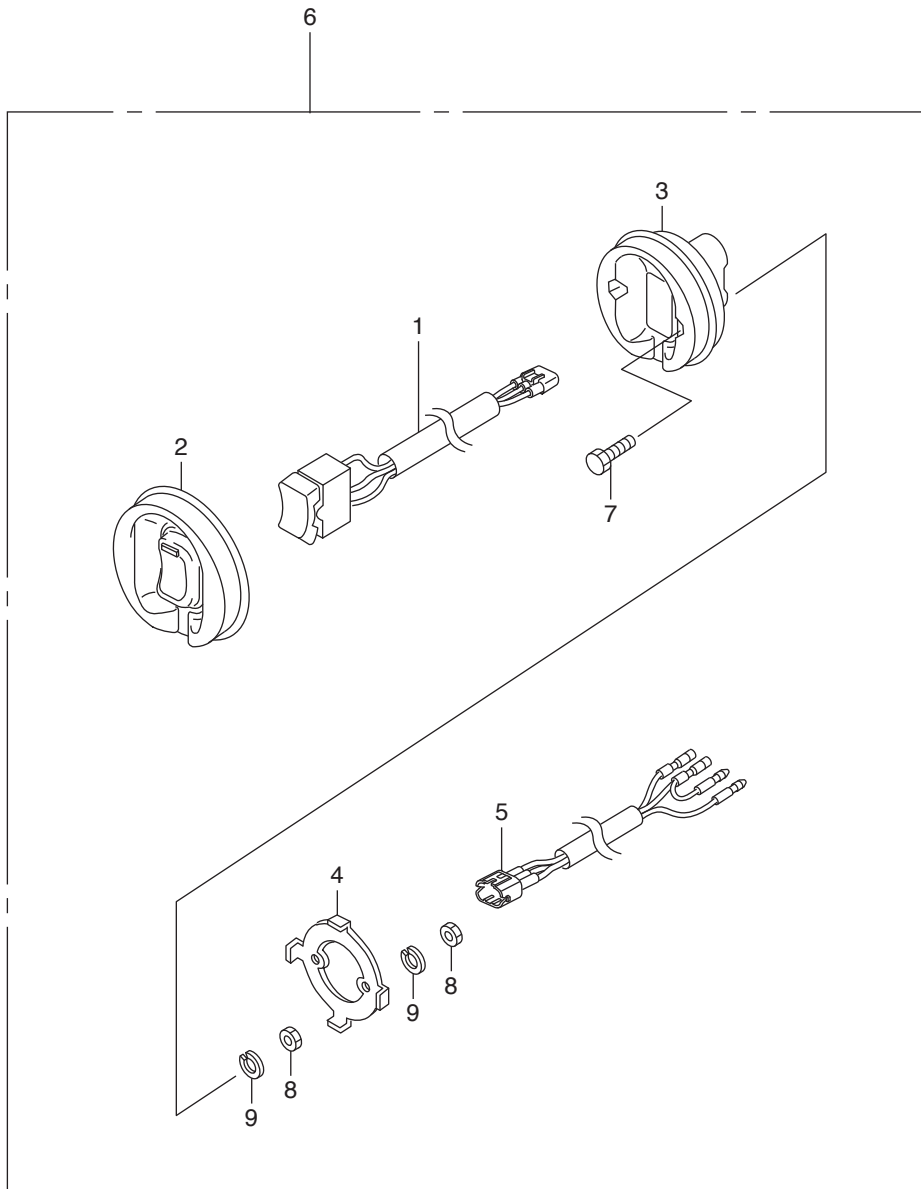



# INDEX

<A>		
ARM ASSY., EX. ROCKER.....	E-9-16	
ARM ASSY., ROCKER.....	E-9-14	
ARM COMP., CAM CHAIN TENSIONER.....	E-9-11	
ARM COMP., CLICK.....	F-2-8	
ARM COMP., LINK JOINT.....	FOP-8-6-18	
ARM COMP., SHIFT LINK.....	FOP-8-6-14	
ARM, NEUTRAL LOCK.....	FOP-8-4-5	
ARM, SHIFT.....	F-2-13	
ARM, THROTTLE.....	F-2-6	
ARMATURE COMP.....	F-11-5	
<B>		
BAG, TOOL, 230MM.....	F-13-12	
BALL, STEEL.....	E-21-6	
BALL, STEEL, #7(7/32).....	F-5-29	
BALL, STEEL, #7(7/32).....	F-5-1-31	
BALL, STEEL, #9(9/32).....	F-5-30	
BALL, STEEL, #9(9/32).....	F-5-1-32	
BAND.....	E-18-10-44	
BAND(BLACK 3.5X140).....	F-8-10-1	
BAND(BLACK 3.5X140).....	FOP-8-6-40	
BAND, AIR FLOW.....	E-15-4	
BAND, HARNESS.....	E-14-34	
BAND, HARNESS OFFSET(10).....	F-7-30-2	
BAND, TUBE CLIP, 12.5MM.....	F-9-16	
BAND, UNDER CASE GROMMET.....	F-8-10-4	
BAND, WIRE.....	F-3-2	
BAND, WIRE.....	F-7-2	
BAND, WIRE.....	F-10-7	
BAND, WIRE HARNESS.....	F-7-10-15	
BAND, WIRE HARNESS(NATURAL).....	FOP-6-24	
BAND, WIRE HARNESS(NATURAL).....	FOP-6-1-17	
BASE.....	FOP-8-4-15	
BASE, INJECTOR.....	E-14-10	
BEARING A, CONNECTING ROD.....	E-7-7	
BEARING A, MAIN LOWER(BLUE).....	E-7-11	
BEARING A, MAIN UPPER(BLUE).....	E-7-9	
BEARING B, CONNECTING ROD.....	E-7-	
BEARING B, MAIN LOWER(BLACK).....	E-7-	
BEARING B, MAIN UPPER(BLACK).....	E-7-	
BEARING C, CONNECTING ROD.....	E-7-	
BEARING C, MAIN LOWER(BROWN).....	E-7-	
BEARING C, MAIN UPPER(BROWN).....	E-7-	
BEARING D, CONNECTING ROD.....	E-7-	
BEARING D, MAIN LOWER(GREEN).....	E-7-	
BEARING D, MAIN UPPER(GREEN).....	E-7-	
BEARING E, CONNECTING ROD.....	E-7-	
BEARING E, MAIN LOWER(YELLOW).....	E-7-	
BEARING E, MAIN UPPER(YELLOW).....	E-7-	
BEARING F, CONNECTING ROD.....	E-7-	
BEARING F, MAIN LOWER(PINK).....	E-7-	
BEARING F, MAIN UPPER(PINK).....	E-7-	
BEARING G, CONNECTING ROD(RED).....	E-7-	
BEARING, FR.....	E-19-4	
BEARING, NEEDLE(25X32X26).....	F-5-24	
BEARING, NEEDLE(25X32X26).....	F-5-1-26	
BEARING, NEEDLE.....	F-4-26	
BEARING, NEEDLE, 20X28X13.....	E-6-42	
BEARING, NEEDLE, 30X37X26.....	F-5-20	
BEARING, NEEDLE, 30X37X26.....	F-5-1-22	
BEARING, RADIAL BALL, 50X90X20.....	F-5-23	
BEARING, RADIAL BALL, 50X90X20.....	F-5-1-25	
BEARING, RR.....	E-19-3	
BEARING, TAPER ROLLER.....	F-4-27	
BEARING, TAPER, 50X90X28.....	F-5-22	
BEARING, TAPER, 50X90X28.....	F-5-1-24	
BEARING, THRUST(F).....	F-5-21	
BEARING, THRUST(F).....	F-5-1-23	
BELT, A.C. GENERATOR(4PK810).....	E-13-3	
BLOCK ASSY., CYLINDER.....	E-3-6	
BLOCK, NEUTRAL LOCK.....	FOP-8-6-6	
BLOCK, THROTTLE FRICTION.....	FOP-8-6-28	
BODY COMP., CHAMBER.....	E-18-10-5	
BODY COMP., OIL JET.....	E-3-8	
BODY, TROLLING CONTROL SWITCH.....	FOP-12-3	
BOLT.....	E-19-14	
BOLT A, HEAD COVER.....	E-9-20-18	
BOLT A, THROUGH.....	E-21-18	
BOLT COMP., OIL JET.....	E-3-9	
BOLT KIT, SIDE REMOTE CONTROL.....	FOP-9-1	
BOLT, 1/4-28UNF.....	F-10-31	
BOLT, 3/8-24UNF.....	F-10-33	
BOLT, CHAIN GUIDE.....	E-10-9	
BOLT, CONNECTING ROD.....	E-7-5	
BOLT, COVER LOCK.....	F-8-8	
BOLT, DRAIN PLUG.....	E-6-37	
BOLT, DRAIN PLUG.....	F-3-14	
BOLT, FLANGE, 10X105.....	E-10-18	
BOLT, FLANGE, 10X110.....	E-6-54	
BOLT, FLANGE, 10X32.....	E-9-31	
BOLT, FLANGE, 10X40.....	E-6-25	
BOLT, FLANGE, 10X40.....	F-3-20-9	
BOLT, FLANGE, 10X40.....	F-5-12	
BOLT, FLANGE, 10X40.....	F-5-1-13	
BOLT, FLANGE, 10X43.....	E-9-10-19	
BOLT, FLANGE, 10X45.....	E-4-11	
BOLT, FLANGE, 10X70.....	E-3-27	
BOLT, FLANGE, 10X70.....	E-9-10-21	
BOLT, FLANGE, 10X75.....	E-4-8	
BOLT, FLANGE, 10X80.....	E-6-29	
BOLT, FLANGE, 10X80.....	E-19-28	
BOLT, FLANGE, 10X90.....	E-21-21	
BOLT, FLANGE, 12MM.....	E-5-15	
BOLT, FLANGE, 12X47.....	E-9-30	
BOLT, FLANGE, 12X83.....	E-3-19	
BOLT, FLANGE, 5X12.....	E-14-28	
BOLT, FLANGE, 6X10.....	E-14-25	
BOLT, FLANGE, 6X12.....	E-6-35	
BOLT, FLANGE, 6X12.....	E-6-36	
BOLT, FLANGE, 6X12.....	E-15-19	
BOLT, FLANGE, 6X12.....	F-2-30	
BOLT, FLANGE, 6X12.....	F-3-20-10	
BOLT, FLANGE, 6X12.....	F-7-4	
BOLT, FLANGE, 6X12.....	F-7-10-10	
BOLT, FLANGE, 6X12.....	F-7-20-7	
BOLT, FLANGE, 6X14.....	E-4-9	
BOLT, FLANGE, 6X14.....	E-9-10-17	
BOLT, FLANGE, 6X14.....	E-9-20-22	
BOLT, FLANGE, 6X14.....	E-10-15	
BOLT, FLANGE, 6X14.....	E-14-24	
BOLT, FLANGE, 6X14.....	E-18-1-13	
BOLT, FLANGE, 6X14.....	F-2-28	
BOLT, FLANGE, 6X14(CT200).....	E-3-21	
BOLT, FLANGE, 6X14(CT200).....	E-9-10-14	
BOLT, FLANGE, 6X14(CT200).....	F-7-10-9	
BOLT, FLANGE, 6X16.....	E-9-10-16	
BOLT, FLANGE, 6X16.....	E-9-20-20	
BOLT, FLANGE, 6X16.....	E-18-10-48	
BOLT, FLANGE, 6X16.....	E-19-24	
BOLT, FLANGE, 6X16.....	F-2-27	
BOLT, FLANGE, 6X18.....	E-6-53	
BOLT, FLANGE, 6X18.....	F-2-29	
BOLT, FLANGE, 6X20.....	E-5-18	
BOLT, FLANGE, 6X20.....	E-6-28	
BOLT, FLANGE, 6X20.....	E-9-36	
BOLT, FLANGE, 6X20.....	E-9-20-21	
BOLT, FLANGE, 6X20.....	E-9-20-29	
BOLT, FLANGE, 6X20.....	E-20-10-5	
BOLT, FLANGE, 6X20.....	F-2-31	
BOLT, FLANGE, 6X20.....	F-4-18	
BOLT, FLANGE, 6X20.....	F-7-20-8	
BOLT, FLANGE, 6X20.....	F-10-34	
BOLT, FLANGE, 6X22.....	E-4-10	
BOLT, FLANGE, 6X22.....	E-6-32	
BOLT, FLANGE, 6X22.....	F-7-10-11	
BOLT, FLANGE, 6X22.....	F-8-10-23	
BOLT, FLANGE, 6X23.....	F-10-30	
BOLT, FLANGE, 6X25.....	E-3-22	
BOLT, FLANGE, 6X25.....	E-5-17	
BOLT, FLANGE, 6X25.....	E-6-27	
BOLT, FLANGE, 6X25.....	E-10-19	
BOLT, FLANGE, 6X25.....	E-18-21	
BOLT, FLANGE, 6X25.....	E-18-10-47	
BOLT, FLANGE, 6X27.....	E-18-19	
BOLT, FLANGE, 6X28.....	E-9-10-15	
BOLT, FLANGE, 6X30.....	E-9-37	
BOLT, FLANGE, 6X32.....	E-9-20-30	
BOLT, FLANGE, 6X32.....	E-10-20	
BOLT, FLANGE, 6X38.....	E-9-10-20	
BOLT, FLANGE, 6X52.....	E-9-20-19	
BOLT, FLANGE, 8X100.....	E-6-34	
BOLT, FLANGE, 8X110.....	E-9-20-32	
BOLT, FLANGE, 8X18.....	F-7-10-12	
BOLT, FLANGE, 8X20.....	E-3-23	
BOLT, FLANGE, 8X20.....	E-19-25	
BOLT, FLANGE, 8X25.....	E-14-31	
BOLT, FLANGE, 8X28.....	E-19-26	
BOLT, FLANGE, 8X30.....	E-6-26	
BOLT, FLANGE, 8X30.....	E-18-10-49	
BOLT, FLANGE, 8X32.....	E-5-27	
BOLT, FLANGE, 8X35.....	E-3-24	
BOLT, FLANGE, 8X35.....	E-14-29	
BOLT, FLANGE, 8X35.....	F-10-66	
BOLT, FLANGE, 8X35.....	FOP-8-6-49	
BOLT, FLANGE, 8X45.....	E-14-30	
BOLT, FLANGE, 8X50.....	E-3-26	
BOLT, FLANGE, 8X50.....	E-10-16	
BOLT, FLANGE, 8X55.....	E-3-18	
BOLT, FLANGE, 8X55.....	E-10-10	
BOLT, FLANGE, 8X55.....	F-8-10-22	
BOLT, FLANGE, 8X60.....	E-15-20	
BOLT, FLANGE, 8X75.....	E-10-17	
BOLT, FLANGE, 8X90.....	E-9-20-31	
BOLT, FRICTION.....	FOP-8-6-29	
BOLT, FUEL PIPE.....	E-14-1	
BOLT, HEX.....	F-11-30	
BOLT, HEX., 10X235.....	F-10-35	
BOLT, HEX., 12X130.....	E-6-31	
BOLT, HEX., 12X130.....	F-10-39	
BOLT, HEX., 12X225.....	F-3-20-12	
BOLT, HEX., 12X70.....	E-6-30	
BOLT, HEX., 4X20.....	FOP-12-7	
BOLT, HEX., 5X16.....	FOP-8-6-68	
BOLT, HEX., 6X12.....	F-4-17	
BOLT, HEX., 6X14.....	F-10-36	
BOLT, HEX., 6X50.....	F-3-20	
BOLT, OIL CHECK.....	F-3-12	
BOLT, RECESSED.....	F-11-27	
BOLT, SEALING, 14MM.....	E-9-4	
BOLT, SEALING, 18MM.....	E-5-7	
BOLT, SEALING, 20MM.....	E-3-2	
BOLT, SEALING, 20MM.....	E-5-1	
BOLT, SEALING, 20MM.....	E-9-20-23	
BOLT, SEALING, 22MM.....	E-5-19	
BOLT, SEALING, 28MM.....	E-3-3	
BOLT, SEALING, 6MM.....	E-18-10-45	
BOLT, SOCKET(A).....	F-11-28	
BOLT, SOCKET(B).....	F-11-29	
BOLT, SOCKET, 6X16.....	F-8-9	
BOLT, SOCKET, 6X20.....	F-8-7	
BOLT, SOCKET, 6X25.....	E-1-5	
BOLT, SOCKET, 6X25.....	E-20-3	
BOLT, SPECIAL ADJUSTER.....	E-19-23	
BOLT, SPECIAL, 6X17.....	F-8-20-14	
BOLT, SPECIAL, 6X220.....	FOP-9-2	
BOLT, SPECIAL, 6X31.....	E-9-10-18	
BOLT, SPECIAL, 8MM.....	E-5-14	
BOLT, STUD.....	E-19-8	
BOLT, STUD 2, 8X25.....	E-14-26	
BOLT, STUD, 10X55.....	E-6-33	
BOLT, STUD, 12X145.....	F-10-32	
BOLT, STUD, 8X32.....	E-14-27	
BOLT, TENSIONER.....	E-19-27	
BOLT, TENSIONER PIVOT.....	E-9-29	
BOLT-WASHER.....	E-19-13	
BOLT-WASHER, 10X30.....	E-10-11	
BOLT-WASHER, 10X32.....	F-3-13	
BOLT-WASHER, 10X40.....	F-3-15	
BOLT-WASHER, 11X155.....	E-9-20-17	
BOLT-WASHER, 11X95.....	E-3-20	
BOLT-WASHER, 16X49.....	E-7-15	
BOLT-WASHER, 5X30.....	E-15-18	
BOLT-WASHER, 6X25.....	E-13-5	
BOLT-WASHER, 6X25.....	E-15-17	
BOLT-WASHER, 6X27(CT200).....	E-20-10-4	
BOLT-WASHER, 8X10.....	E-3-10	
BOLT-WASHER, 8X30.....	F-3-20-11	



BOLT-WASHER, 8X30	F-8-10-24	CAP, GRIP	FOP-8-7	CLIP, WIRE HARNESS	F-10-58
BOLT-WASHER, 8X35	E-14-23	CAP, GRIP	FOP-8-2-9	CLIP, WIRE HARNESS(6.3MM)	FOP-8-6-65
BOLT-WASHER, 8X35	E-18-20	CAP, HANDLE	FOP-8-6-5	CLIP, WIRE HARNESS, 25MM	E-18-1-15
BOLT-WASHER, 8X35	E-18-10-46	CAP, L. SIDE COVER	F-8-10-21	CLUTCH COMP., OVERRUNNING	E-21
BOLT-WASHER, 8X40	F-4-19	CAP, OIL(YELLOW)	E-3-11	CLUTCH COMP., OVERRUNNING	E-21
BOLT-WASHER, 8X40	FOP-10-1-8	CAP, REGULATOR	E-14-6	COIL COMP., PLUG HOLE	E-20-1
BOSS, FLYWHEEL	E-5-13	CAP, SWITCH	FOP-8-8	COLLAR	E-18-10-23
BOX ASSY., JUNCTION	F-7-20-1	CAP, WATER JOINT	F-8-20-1	COLLAR	E-18-10-26
BOX ASSY., REMOTE CONTROL(EU)	FOP-8-6-1	CARTRIDGE, OIL FILTER	E-5-10	COLLAR, 8.5X14.5	E-14-39
BOX KIT, REMOTE CONTROL	FOP-8-1	CASE ASSY., BALANCER HOLDER	E-10-1	COLLAR, 8.5X14.5	E-18-28
BOX KIT, REMOTE CONTROL	FOP-8-2-1	CASE ASSY., CHAIN	E-9-10-1	COLLAR, 8.5X14.5	E-18-10-53
BOX KIT, REMOTE CONTROL	FOP-8-4-1	CASE ASSY., ELECTRONIC PARTS	E-20-10-1	COLLAR, C.D.I. UNIT CASE	E-13-8
BRACKET A, CABLE	F-2-21	CASE ASSY., GEAR(L)	F-3-10-1	COLLAR, C.D.I. UNIT CASE	E-15-22
BRACKET A, COUPLER	F-7-10-1	CASE ASSY., GEAR(XL)	F-3-10-1	COLLAR, C.D.I. UNIT CASE	E-20-10-6
BRACKET A, HARNESS CLIP	E-14-15	CASE ASSY., GEAR(XL)	F-3-10-1	COLLAR, C.D.I. UNIT CASE	F-7-10-18
BRACKET ASSY.	F-11-4	CASE COMP., MOUNT	E-6-22	COLLAR, CAMSHAFT	E-9-35
BRACKET B, CABLE	F-7-10-6	CASE COMP., PUMP	E-18-10-27	COLLAR, DISTANCE	F-4-34
BRACKET B, HARNESS CLIP	E-9-10-9	CASE COMP., SILENCER	E-15-5	COLLAR, DISTANCE	FOP-10-1-11
BRACKET C, HARNESS CLIP	E-9-10-10	CASE, EXTENSION	F-3-20-1	COLLAR, DISTANCE(A)	FOP-9-3
BRACKET COMP., A.C. GENERATOR	E-19-17	CASE, EXTENSION(L)	F-3-20-2	COLLAR, DISTANCE(B)	FOP-9-4
BRACKET D, HARNESS CLIP	E-3-14	CASE, GEAR	F-3-3	COLLAR, DISTANCE, 6.5X9X3	F-8-12
BRACKET E, HARNESS CLIP	E-15-9	CASE, OIL	E-6-1	COLLAR, DISTANCE, 6.5X9X5	F-8-20-19
BRACKET F, CLIP	E-9-20-14	CASE, SWIVEL	F-10-15	COLLAR, DISTANCE, 6X10X43.5	FOP-8-6-67
BRACKET, BUZZER	FOP-6-21	CHAIN(176L)(DAIDO)	E-9-8	COLLAR, LINK JOINT	FOP-8-6-66
BRACKET, BUZZER	FOP-6-1-14	CHAIN(G2L)	E-10-5	COLLAR, LOWER CYLINDER	F-10-29
BRACKET, CLIP B	E-3-13	CIRCLIP, EXTERNAL, 14MM	F-5-28	COLLAR, LOWER MOUNTING	F-3-20-7
BRACKET, FR.	E-21-10	CIRCLIP, EXTERNAL, 14MM	F-5-1-30	COLLAR, ORIFICE	F-11-44
BRACKET, FR. UNDER COVER	F-8-10-5	CIRCLIP, EXTERNAL, 39MM	F-10-57	COLLAR, SLIDING PLATE	FOP-8-6-16
BRACKET, HOOK	F-8-3	CIRCLIP, INTERNAL	F-11-32	COLLAR, STEERING ROD	F-10-62
BRACKET, L. SIDE COVER	F-8-10-7	CIRCLIP, INTERNAL, 40	F-3-20-17	CONTROL UNIT, ELECTRONIC	E-20-10-3
BRACKET, L. STERN	F-10-20	CLAMP	F-6-5	CORD ASSY., INDICATOR(20FT)	FOP-6-4
BRACKET, LINK JOINT	FOP-8-6-19	CLAMP	F-6-8	CORD ASSY., INDICATOR(25FT)	FOP-6-4
BRACKET, NEUTRAL SWITCH	F-2-23	CLAMP B, WATER TUBE	E-4-12	CORD ASSY., INDICATOR(30FT)	FOP-6-4
BRACKET, R. SIDE COVER	F-8-10-6	CLAMP, 18.5MM	E-9-10-28	CORD COMP., EMERGENCY	FOP-6-15
BRACKET, R. STERN	F-10-19	CLAMP, 18.5MM	E-13-7	CORD COMP., EMERGENCY	FOP-6-1-9
BRACKET, RELAY	E-3-17	CLAMP, ENGINE SUB CORD	F-7-30-3	CORD COMP., EMERGENCY	FOP-8-6-42
BRACKET, REMOTE CONTROL	FOP-8-12	CLAMP, FUEL HOSE	E-15-23	COTTER, VALVE(FUJI VALVE)	E-9-28
BRACKET, REMOTE CONTROL	FOP-8-2-13	CLAMP, HARNESS	FOP-8-6-9	COVER ASSY.	FOP-8-4-11
BRACKET, RR.	E-21-11	CLAMP, HOSE	E-18-11	COVER ASSY., ENGINE	F-8-1
BRACKET, SENSOR CORD	E-15-10	CLAMP, HOSE	F-7-30-1	COVER B, TERMINAL	F-7-10-5
BRACKET, SHIFT LINK	F-2-19	CLAMP, PIPE	E-18-12	COVER B, TERMINAL(L)	F-7-3
BRACKET, TILTING	F-10-24	CLAMP, POWER TILT CORD	FOP-8-6-31	COVER B, TERMINAL(L)	F-7-10-4
BRACKET, TROLLING CONTROL	FOP-12-4	CLAMP, PURGE HOSE	E-18-30	COVER COMP.	E-18-10-6
BRACKET, WATER TUBE CLAMP	E-4-5	CLAMP, TUBE(8.0)	E-18-10-51	COVER COMP., CYLINDER HEAD	E-1-1
BREAKER ASSY.	F-11-1	CLAMP, TUBE(D10.5)	E-4-10-8	COVER COMP., FUSE	F-7-20-2
BRUSH ASSY.	F-11-2	CLAMP, TUBE(D10.5)	E-6-40	COVER COMP., PLUG HOLE COIL	E-1-4
BRUSH SET	E-21-7	CLAMP, TUBE(D10.5)	E-6-41	COVER, BEARING	E-19-5
BRUSH SET	E-21-	CLAMP, TUBE(D10.7)	E-18-22	COVER, CHAIN CASE	E-9-10-2
BUFFER, PLATE	E-18-1-4	CLAMP, TUBE(D17)	E-15-21	COVER, DRAIN PLUG	F-8-20-8
BUSH A, COVER LOCK	F-2-25	CLAMP, TUBE(D25.0)	E-4-10-10	COVER, DUAL GRIP	FOP-8-2-8
BUSH A, COVER LOCK	F-8-10-11	CLAMP, TUBE(D32.5)	E-4-10-9	COVER, EX. MANIFOLD	E-4-3
BUSH A, COVER LOCK	F-8-10-12	CLAMP, WATER TUBE	E-4-10-11	COVER, FLUSH VALVE	E-6-15
BUSH B, COVER LOCK	F-8-10-13	CLIP B1, TUBE	F-9-13	COVER, FR. SEPARATE	F-8-20-6
BUSH COMP., VERTICAL SHAFT	F-3-20-3	CLIP(10.7MM)	F-10-69	COVER, GEAR CASE	F-3-5
BUSH, BLADE BRAKE	F-2-26	CLIP(14MM)	F-10-56	COVER, GRIP	FOP-8-4-4
BUSH, INSULATION	E-19-20	CLIP, BRAKE PIPE(A)	F-2-24	COVER, IMPELLER	F-4-5
BUSH, LOWER CYLINDER	F-11-23	CLIP, EMERGENCY LOCK	FOP-6-16	COVER, IMPELLER	FOP-10-1-5
BUSH, MOTOR CODE	F-10-27	CLIP, EMERGENCY LOCK	FOP-6-1-10	COVER, L. ENGINE UNDER	F-8-20-10
BUSH, MOTOR CODE	F-10-68	CLIP, EMERGENCY LOCK	FOP-8-6-43	COVER, L. GRIP	FOP-8-5
BUSH, SWIVEL CASE	F-10-18	CLIP, FUEL HOSE	E-18-25	COVER, L. GRIP	FOP-8-2-6
BUSH, SWIVEL CASE	F-11-9	CLIP, FUEL TUBE, 14.	E-14-35	COVER, LOCK ARM	FOP-8-4-6
BUSH, TILT ARM	F-10-23	CLIP, FUEL TUBE, 14.	F-7-10-16	COVER, OIL PUMP	E-5-4
BUTTON, THROTTLE	FOP-8-9	CLIP, HARNESS	E-18-27	COVER, PUMP(A)	E-18-10-29
BUTTON, THROTTLE	FOP-8-2-10	CLIP, HARNESS BAND(BLACK)	E-3-38	COVER, PUMP(B)	E-18-10-28
BUTTON, THROTTLE	FOP-8-4-8	CLIP, HARNESS BAND(BLACK)	F-7-7	COVER, R. ENGINE UNDER	F-8-20-9
BUZZER COMP., WARNING	FOP-6-20	CLIP, HARNESS BAND(BLACK)	F-7-10-17	COVER, RELIEF VALVE	E-6-19
BUZZER COMP., WARNING	FOP-6-1-13	CLIP, HARNESS BAND(BLACK)	FOP-11-6	COVER, STARTER TERMINAL	F-7-10-3
BUZZER COMP., WARNING	FOP-8-6-46	CLIP, HARNESS BAND(NATURAL)	E-4-17	COVER, THERMOSTAT	E-9-10-6
<C>		CLIP, INJECTOR	E-14-3	COVER, WATER JACKET	E-18-10-12
CABLE ASSY., REMOTE CONTROL(B)	FOP-8-6-34	CLIP, MUDGUARD	F-8-20-17	CRANKCASE COMP.	E-3-1
CABLE ASSY., STARTER	F-7-10-2	CLIP, PISTON PIN	E-7-4	CRANKSHAFT COMP.	E-7-8
CABLE ASSY., SWITCH PANEL	FOP-6-9	CLIP, SENSOR HOSE	E-18-18	CUP SET, WATER SEPARATOR	E-18-1-3
CABLE ASSY., SWITCH PANEL	FOP-6-	CLIP, TUBE	E-18-1	CUP, FUEL STRAINER	E-18-1-8
CABLE ASSY., SWITCH PANEL	FOP-6-	CLIP, TUBE	E-18-1-1	<D>	
CABLE COMP. A, COVER LOCK	F-8-10-8	CLIP, TUBE(B1 14.5)	E-18-23	DAMPER, HOOK	F-8-4
CABLE COMP. B, COVER LOCK	F-8-10-9	CLIP, TUBE(B12)	E-18-24	DOWEL PIN, 10X12	E-7-17
CABLE SET, PANEL INDICATOR	FOP-6-2	CLIP, TUBE(B12)	E-18-1-14	DOWEL PIN, 10X16	E-5-25
CABLE SET, PANEL INDICATOR	FOP-6-	CLIP, TUBE(B12)	F-9-12	DOWEL PIN, 10X16	E-6-48
CABLE SET, PANEL INDICATOR	FOP-6-	CLIP, TUBE(B8)	F-10-55	DOWEL PIN, 10X16	E-9-20-27
CAMSHAFT COMP., EX.	E-9-5	CLIP, TUBE(BLACK)(135MM)	E-18-29	DOWEL PIN, 13X14	E-3-32
CAMSHAFT COMP., IN.	E-9-2	CLIP, TUBE, 3.5.	E-13-6	DOWEL PIN, 13X20	E-3-31
CAP COMP., OIL TANK	F-11-26	CLIP, WIRE HARNESS	F-7-6	DOWEL PIN, 14X20	E-5-26
CAP, BOLT, 8MM	E-3-25	CLIP, WIRE HARNESS	F-8-20-18	DOWEL PIN, 14X20	E-6-49

DOWEL PIN, 14X20 .....	E-9-20-28	GUIDE COMP., BALANCER SHAFT .....	E-10-7	LABEL, WARNING OPERATOR .....	F-12-11
DOWEL PIN, 18X13 .....	E-10-12	GUIDE COMP., CAM CHAIN .....	E-9-12	LAMP ASSY., INDICATION .....	FOP-8-6-44
DOWEL PIN, 18X22 .....	E-3-30	GUIDE COMP., EX. ....	E-6-8	LAMP ASSY., INDICATION(4-LED) .....	FOP-6-18
DOWEL PIN, 4.2X10.3 .....	E-9-34	GUIDE COMP., ROD .....	F-11-14	LAMP ASSY., INDICATION(4-LED) .....	FOP-6-1-11
DOWEL PIN, 6X10 .....	E-6-47	GUIDE COMP., ROD .....	F-11-15	LEVER SET .....	E-21-17
DOWEL PIN, 6X10 .....	F-3-18	GUIDE, ENGINE COVER AIR .....	F-8-6	LEVER, COVER LOCK .....	F-8-10-10
DOWEL PIN, 6X10 .....	F-3-20-18	GUIDE, EX. VALVE(OS) .....	E-9-20-3	LEVER, HANDLE LOCK .....	FOP-8-6-3
DOWEL PIN, 6X10 .....	F-4-25	GUIDE, IN. VALVE(OS) .....	E-9-20-2	LEVER, IDLE .....	FOP-8-6-22
DOWEL PIN, 8X10 .....	E-10-13	<H>		LINE, FUEL .....	E-14-4
DRIVER, SCREW(NO.2 + -) .....	F-13-1	HANDLE, REMOTE CONTROL .....	FOP-8-4	LINER, PUMP .....	F-4-4
DUCT A, SILENCER .....	E-13-1	HANDLE, REMOTE CONTROL .....	FOP-8-2-5	LINER, PUMP .....	FOP-10-1-4
DUCT B, SILENCER .....	E-13-2	HANDLE, REMOTE CONTROL .....	FOP-8-4-3	LINER, SWIVEL CASE .....	F-10-17
<E>		HANDLE, REMOTE CONTROL .....	FOP-8-6-2	LINK, THROTTLE .....	F-2-3
END COVER, RR .....	E-19-19	HANGER B, ENGINE .....	E-19-1	LINKAGE, PIVOT .....	F-2-1
END, NIPPLE .....	F-3-10	HANGER, ENGINE .....	E-3-5	LOCK COMP., FR. ....	F-8-10-19
E-RING, 10MM .....	F-4-35	HARNESS ASSY., MAIN WIRE .....	F-7-1	LOCK COMP., SIDE .....	F-8-10-20
E-RING, 12MM .....	F-2-50	HARNESS ASSY., REMOTE CONTROL .....	FOP-11-2	LOW PERMEATION HOSE L=1600 .....	F-6-7
E-RING, 15MM .....	F-11-45	HARNESS ASSY., SWITCH PANEL .....	FOP-6-8	LOW PERMEATION HOSE L=700 .....	F-6-6
E-RING, 3MM .....	FOP-8-6-77	HARNESS ASSY., SWITCH PANEL .....	FOP-6-1-4	<M>	
E-RING, 4MM .....	F-2-48	HARNESS COMP. ....	E-18-10-43	MANIFOLD COMP., EX. ....	E-4-2
E-RING, 4MM .....	FOP-8-6-78	HARNESS, TROLLING CONTROL .....	FOP-12-5	MANIFOLD COMP., INTAKE .....	E-14-14
E-RING, 6MM .....	F-2-49	HEAD KIT, CYLINDER .....	E-9-20-1	MARK, FAST IDLE .....	FOP-8-6-48
E-RING, 6MM .....	F-8-10-29	HOLDER .....	E-18-10-11	MARK, FLUSH MOUNT .....	FOP-8-4-19
E-RING, 6MM .....	FOP-8-36	HOLDER ASSY., BRUSH .....	E-19-2	MARK, FR. EMBLEM(TOYOTA) .....	F-12-16
E-RING, 6MM .....	FOP-8-2-41	HOLDER COMP., BRUSH .....	E-21-9	MARK, HANDLE FLUSH MOUNT .....	FOP-8-4-18
E-RING, 6MM .....	FOP-8-4-28	HOLDER COMP., BRUSH .....	E-21-	MARK, L. SIDE STRIPE .....	F-12-15
E-RING, 7MM .....	FOP-8-6-79	HOLDER, BEARING .....	F-5-1-11	MARK, R. SIDE STRIPE .....	F-12-14
<F>		HOLDER, DRAIN TUBE .....	F-2-46	MARK, REMOTE CONTROL(DUAL) .....	FOP-8-2-24
FILTER ASSY., SPOOL VALVE .....	E-9-20-9	HOLDER, NEUTRAL LOCK .....	FOP-8-4-14	MARK, REMOTE CONTROL(SINGLE) .....	FOP-8-21
FILTER ASSY., VTC .....	E-9-20-13	HOLDER, OIL FILTER .....	E-5-16	MARK, RR.(BFT150) .....	F-12-13
FILTER B .....	F-11-16	HOLDER, PROPELLER SHAFT .....	F-5-10	METAL COMP., ANODE .....	F-3-9
FILTER COMP., ELECTRONIC AIR .....	E-14-19	HOLDER, PROPELLER SHAFT .....	F-5-1-10	METAL KIT, ANODE .....	F-10-1
FLANGE COMP., OIL FILTER .....	E-5-11	HOLDER, SEAL .....	F-2-20	METAL, ANODE .....	E-4-1
FLOAT SET .....	E-18-10-2	HOLDER, SHIFT ROD .....	F-4-11	METAL, BALANCER SHAFT(DAIDO) .....	E-10-8
FLYWHEEL COMP. ....	E-5-12	HOLDER, UPPER MOUNTING .....	F-10-13	METER LEAD WIRE .....	FOP-2-6
FRAME COMP., MOUNTING .....	F-10-11	HOSE COMP., FUEL .....	E-18-6	MOTION COMP., LOST .....	E-9-20-7
FUSE, BLOCK 100A(L TYPE) .....	F-7-20-3	HOSE, PRESSURE REGULATOR .....	E-18-13	MOTOR ASSY., POWER TILT .....	F-11-3
FUSE, MINI(10A) .....	F-7-20-10	HOUSING ASSY., L. INNER .....	FOP-8-3	MOTOR ASSY., STARTER .....	E-21-1
FUSE, MINI(15A) .....	F-7-20-11	HOUSING ASSY., L. INNER .....	FOP-8-2-3	MOUNT COMP., UPPER RUBBER .....	F-10-12
FUSE, MINI(30A) .....	F-7-20-12	HOUSING ASSY., R. INNER .....	FOP-8-2-4	<N>	
<G>		HOUSING ASSY., R. INNER .....	FOP-8-4-2	NIPPLE, GREASE .....	F-10-59
GASKET A, INJECTOR BASE .....	E-14-11	HOUSING COMP., REMOTE CONTROL .....	FOP-8-13	NIPPLE, SENSOR .....	F-3-11
GASKET B, IMPELLER .....	F-4-6	HOUSING COMP., REMOTE CONTROL .....	FOP-8-2-14	NUT, ADJUSTER ROD .....	F-10-43
GASKET B, IMPELLER .....	FOP-10-3	HOUSING COMP., REMOTE CONTROL .....	FOP-8-6-10	NUT, CASTLE, 18MM .....	F-5-13
GASKET B, IMPELLER .....	FOP-10-1-6	HOUSING COMP., REMOTE CONTROL .....	FOP-8-6-11	NUT, CASTLE, 18MM .....	F-5-1-14
GASKET COMP., CYLINDER HEAD .....	E-9-20-6	HOUSING, IMPELLER .....	F-4-3	NUT, CLIP .....	F-8-20-15
GASKET COMP., EX. MANIFOLD .....	E-4-4	HOUSING, IMPELLER .....	FOP-10-1-3	NUT, FLANGE CAP, 10MM .....	E-3-28
GASKET, EX. GUIDE .....	E-6-9	HOUSING, LEAD .....	FOP-8-14	NUT, FLANGE CAP, 6MM .....	E-1-6
GASKET, IDLE EX. PORT .....	E-6-11	HOUSING, LEAD .....	FOP-8-2-15	NUT, FLANGE, 10MM .....	F-10-44
GASKET, MOUNT CASE .....	E-6-23	HOUSING, LOWER CENTER MOUNTING .....	F-3-20-8	NUT, FLANGE, 12MM .....	F-3-20-14
GASKET, UPPER MOUNTING HOLDER .....	F-10-14	HOUSING, LOWER MOUNTING .....	F-3-20-5	NUT, FLANGE, 12MM .....	F-10-40
GAUGE COMP., OIL LEVEL .....	E-6-5	HOUSING, REMOTE CONTROL BOX(C) .....	FOP-8-6-12	NUT, FLANGE, 5MM .....	FOP-6-3
GEAR ASSY., INTERNAL .....	E-21-15	HOUSING, WATER SEAL .....	F-4-15	NUT, FLANGE, 5MM .....	FOP-6-1-2
GEAR ASSY., PLANETARY .....	E-21-3	<I>		NUT, FLANGE, 6MM .....	E-14-33
GEAR ASSY., INTERNAL .....	E-21-23	IMPELLER, PUMP .....	F-4-2	NUT, FLANGE, 8MM .....	E-14-32
GEAR COMP., BEVEL(FORWARD 30T) .....	F-5-7	IMPELLER, PUMP .....	FOP-10-2	NUT, FLANGE, 8MM .....	E-19-29
GEAR COMP., BEVEL(RVS. 30T) .....	F-5-1-8	IMPELLER, PUMP .....	FOP-10-1-2	NUT, HEX., 12MM .....	F-10-63
GEAR, BEVEL(FORWARD 30T) .....	F-5-1-7	INJECTOR ASSY., FUEL .....	E-14-2	NUT, HEX., 16MM .....	F-8-20-16
GEAR, BEVEL(RVS. 30T) .....	F-5-8	INSULATOR .....	E-18-10-31	NUT, HEX., 16MM .....	FOP-6-23
GEAR, PINION .....	F-4-16	INSULATOR COMP. ....	E-18-10-30	NUT, HEX., 16MM .....	FOP-6-1-16
GENERATOR ASSY., A.C. ....	E-19-15	<J>		NUT, HEX., 16MM .....	FOP-8-6-53
GRIP .....	F-13-2	JOINT A, BREATHER .....	F-10-4	NUT, HEX., 18MM .....	F-4-21
GRIP, REMOTE CONTROL HANDLE .....	FOP-8-6	JOINT ASSY (INLET) .....	F-6-2	NUT, HEX., 20MM .....	F-2-32
GRIP, REMOTE CONTROL HANDLE .....	FOP-8-2-7	JOINT ASSY (OUTLET) .....	F-6-3	NUT, HEX., 4MM .....	FOP-12-8
GRIP, REMOTE CONTROL HANDLE .....	FOP-8-6-4	JOINT SET .....	E-18-10-8	NUT, HEX., 5MM .....	F-2-47
GROMMET, ELECTRONIC PARTS CASE .....	E-20-10-2	JOINT, DRIVE .....	F-11-13	NUT, HEX., 5MM .....	FOP-8-29
GROMMET, EXTENSION CASE .....	F-4-12	JOINT, FOUR-WAY .....	E-4-10-6	NUT, HEX., 5MM .....	FOP-8-35
GROMMET, GEAR CASE .....	F-3-4	JOINT, FUEL PIPE .....	E-14-8	NUT, HEX., 5MM .....	FOP-8-2-33
GROMMET, POWER TILT SWITCH .....	F-8-20-4	JOINT, FUEL PIPE .....	E-14-9	NUT, HEX., 5MM .....	FOP-8-2-34
GROMMET, RELAY .....	F-7-10-8	JOINT, FUEL PIPE .....	E-18-10-39	NUT, HEX., 5MM .....	FOP-8-2-40
GROMMET, REMOTE CONTROL CABLE .....	F-8-10-2	JOINT, FUEL TUBE .....	E-4-10-2	NUT, HEX., 5MM .....	FOP-8-6-76
GROMMET, SILENCER .....	E-15-6	JOINT, FUEL TUBE .....	F-9-7	NUT, HEX., 6MM .....	E-19-31
GROMMET, SILENCER DUCT .....	E-15-7	JOINT, FUEL TUBE .....	F-9-15	NUT, HEX., 6MM .....	F-8-14
GROMMET, TA SENSOR .....	E-15-14	JOINT, WATER HOSE .....	F-9-10	NUT, HEX., 6MM .....	FOP-8-4-25
GROMMET, UNDER CASE .....	E-13-4	<K>		NUT, HEX., 6MM .....	FOP-8-6-54
GROMMET, UNDER CASE .....	E-15-15	KEY, 4.5X21 .....	E-7-16	NUT, HEX., 6MM .....	FOP-8-6-75
GROMMET, UNDER CASE(C) .....	F-8-10-3	KEY, WOODRUFF .....	F-4-24	NUT, LOCK, 64MM .....	F-4-20
GROMMET, UNDER COVER .....	F-8-20-5	KEY, WOODRUFF .....	FOP-10-4	NUT, PULLY LOCK .....	E-19-7
GROMMET, VAPOR SEPARATOR .....	E-18-10-34	KEY, WOODRUFF .....	FOP-10-1-9	NUT, SELF-LOCK(25X2.0) .....	F-10-42
GROMMET, VAPOR SEPARATOR .....	E-18-10-35	KIT, CABLE(NMEA)(6FT) .....	FOP-11-1	NUT, SELF-LOCK(3/8-24UNF) .....	F-10-45
GROMMET, WATER CHECK .....	F-8-20-13	<L>		NUT, SELF-LOCK(7/8-14UNF) .....	F-10-41
GROMMET, WATER TUBE .....	E-6-12	LABEL, FUSE .....	F-12-1	NUT, SELF-LOCK, 5MM .....	F-3-17
GUIDE COMP. B, CAM CHAIN .....	E-9-13	LABEL, OIL CAUTION(E) .....	F-12-10	NUT, SELF-LOCK, 6MM .....	F-3-16

NUT, TAPPET ADJUSTING .....	E-9-32	PANEL ASSY., INDICATOR(4-LED) .....	FOP-6-17	PROPELLER COMP., THREE BLADES .....	F-5-
NUT, TAPPET ADJUSTING .....	E-9-33	PANEL ASSY., SWITCH .....	FOP-6-5	PROPELLER COMP., THREE BLADES .....	F-5-
NUT, WATER MOUTH .....	F-9-9	PANEL ASSY., TROLLING CONTROL .....	FOP-12-6	PROPELLER COMP., THREE BLADES .....	F-5-
NUT-WASHER, 5MM .....	E-19-30	PANEL KIT, SWITCH(4-LED) .....	FOP-6-1-1	PROPELLER COMP., THREE BLADES .....	F-5-
NUT-WASHER, 6MM .....	F-7-5	PANEL KIT, SWITCH(B)(4-LED) .....	FOP-6-1	PROPELLER COMP., THREE BLADES .....	F-5-
NUT-WASHER, 8MM .....	F-7-10-13	PANEL, CONTROL .....	FOP-6-6	PROPELLER COMP., THREE BLADES .....	F-5-
<O>		PANEL, CONTROL .....	FOP-6-7	PROPELLER COMP., THREE BLADES .....	F-5-1-12
OIL SEAL .....	F-11-33	PANEL, CONTROL .....	FOP-6-1-3	PROPELLER COMP., THREE BLADES .....	F-5-1-
OIL SEAL, 14X26X6 .....	F-2-43	PIN A, DOWEL, 12X16 .....	E-10-14	PROPELLER COMP., THREE BLADES .....	F-5-1-
OIL SEAL, 31X46X7(NOK) .....	E-5-21	PIN, 6X6 .....	FOP-8-6-63	PROPELLER COMP., THREE BLADES .....	F-5-1-
OIL SEAL, 39.5X52X6(ARAI) .....	F-10-60	PIN, LINK .....	F-2-38	PROPELLER COMP., THREE BLADES .....	F-5-1-
OIL SEAL, 43X58X7(ARAI) .....	E-9-10-22	PIN, LINK .....	F-2-40	PULLER, MINI FUSE .....	F-7-20-4
OIL SEAL, 46X60X9 .....	E-5-20	PIN, LOCK, 6MM .....	FOP-8-6-62	PULLEY .....	E-19-6
OIL SEAL, 80X98X10(ARAI) .....	E-3-33	PIN, PISTON .....	E-7-3	PULLEY, CRANKSHAFT .....	E-7-14
ORIFICE, LOWER BLOCK .....	E-3-4	PIN, SHIFT LINK .....	F-2-39	PUMP ASSY. ....	F-11-11
ORIFICE, OIL JET .....	E-3-7	PIN, SHIFTER, 8X47 .....	F-5-2	PUMP ASSY., FUEL .....	E-18-5
O-RING .....	E-15-12	PIN, SHIFTER, 8X47 .....	F-5-1-2	PUMP ASSY., OIL .....	E-5-2
O-RING .....	E-18-1-11	PIN, SNAP, 12MM .....	F-2-41	PUMP KIT, IMPELLER .....	FOP-10-1
O-RING .....	E-18-10-13	PIN, SPLIT, 4.0 .....	F-5-19	PUMP KIT, IMPELLER .....	FOP-10-1-1
O-RING .....	E-18-10-14	PIN, SPLIT, 4.0 .....	F-5-1-21	PUMP UNIT, FUEL .....	E-18-10-4
O-RING .....	E-18-10-15	PIN, SPRING, 2.5X20 .....	F-10-64	PUMP UNIT, FUEL .....	E-18-10-37
O-RING .....	E-18-10-16	PIN, UPPER CYLINDER .....	F-11-24	PUMP UNIT, FUEL(B) .....	E-18-10-9
O-RING .....	E-18-10-17	PIPE COMP., OIL LEVEL .....	E-6-6	<R>	
O-RING .....	E-18-10-18	PIPE, HARNESS GUIDE .....	FOP-8-6-32	RECEIVER, THRUST .....	F-10-28
O-RING .....	E-18-10-19	PISTON A .....	E-7-2	RECTIFIER ASSY. ....	E-19-21
O-RING SET, 3.5X31.7 .....	F-11-41	PISTON B .....	E-7-	REGULATOR ASSY. ....	E-19-22
O-RING, 1.8X69.6 .....	F-11-35	PISTON COMP., FREE .....	F-11-20	REGULATOR ASSY., PRESSURE .....	E-14-5
O-RING, 1.8X7.7 .....	F-11-37	PIVOT, SHIFT .....	F-2-15	RELAY ASSY., FUEL PUMP(DENSO) .....	F-7-20-5
O-RING, 1.9X11 .....	F-11-38	PIVOT, SHIFT .....	FOP-8-6-17	RELAY ASSY., POWER TILT .....	F-7-10-7
O-RING, 105X3.1 .....	F-5-27	PIVOT, SHIFT SLIDE .....	F-2-16	RELAY ASSY., POWER(12V-20A) .....	F-7-20-6
O-RING, 105X3.1 .....	F-5-1-29	PLATE .....	E-18-1-12	RETAINER, VALVE SPRING .....	E-9-26
O-RING, 11.5X3.5 .....	E-6-45	PLATE .....	E-18-10-10	RING .....	E-18-10-32
O-RING, 13X1.5(ARAI) .....	E-3-37	PLATE COMP., SLIDING .....	FOP-8-6-15	RING SET, PISTON(STD.) .....	E-7-1
O-RING, 15.54X2.26 .....	F-10-61	PLATE COMP., THROTTLE .....	F-2-4	RING, BACK UP .....	F-11-17
O-RING, 15X1.9 .....	E-9-10-27	PLATE SET, TRANSOM(5.5MM FLAT) .....	FOP-7-2	RING, CROSS PIN .....	F-5-3
O-RING, 15X1.9 .....	E-9-20-24	PLATE SET, TRIM ADJUST .....	FOP-7-1	RING, CROSS PIN .....	F-5-1-3
O-RING, 15X1.9 .....	E-9-20-25	PLATE, CABLE CLAMP .....	FOP-8-11	RING, INNER(15X20X23) .....	F-2-42
O-RING, 16MM .....	E-6-44	PLATE, CABLE CLAMP .....	FOP-8-2-12	RING, STOPPER .....	F-2-11
O-RING, 2.0X70.5 .....	F-11-34	PLATE, CRANK PULSER .....	E-7-13	RING, WATER TUBE SEAL .....	F-4-8
O-RING, 20.6X2.6 .....	E-6-46	PLATE, DWELL .....	FOP-8-15	RING, WATER TUBE SEAL .....	FOP-10-1-7
O-RING, 22.5X2.4 .....	E-5-22	PLATE, DWELL .....	FOP-8-2-16	ROD COMP. A, SHIFT(L) .....	F-2-10
O-RING, 25X2.4(NOK) .....	F-2-45	PLATE, DWELL .....	FOP-8-4-10	ROD COMP. A, SHIFT(XL) .....	F-2-
O-RING, 26X2.7 .....	E-3-34	PLATE, HANDLE .....	FOP-8-10	ROD COMP., CONNECTING .....	E-7-6
O-RING, 3.5X35.7 .....	F-11-39	PLATE, HANDLE .....	FOP-8-2-11	ROD COMP., PISTON .....	F-11-18
O-RING, 3.5X38.7 .....	F-11-36	PLATE, LEVER SETTING .....	FOP-8-6-8	ROD COMP., PISTON .....	F-11-19
O-RING, 3.5X41.7 .....	F-11-40	PLATE, LOCK .....	F-2-17	ROD COMP., PISTON(B) .....	F-11-12
O-RING, 33.2X2.4(NOK) .....	E-18-26	PLATE, REMOTE CONTROL .....	FOP-8-6-47	ROD COMP., SHIFT .....	F-4-9
O-RING, 37X2.4 .....	E-4-15	PLATE, REMOTE CONTROL CABLE .....	F-2-5	ROD COMP., SHIFT .....	F-4-
O-RING, 55.6X3.5 .....	F-4-31	PLATE, RUBBER SETTING .....	F-3-1	ROD COMP., THROTTLE .....	F-2-2
O-RING, 58.5X3.5 .....	F-4-33	PLATE, SHIFT .....	F-5-6	ROD KIT, STEERING .....	F-10-3
O-RING, 59.4X3.1 .....	E-21-22	PLATE, SHIFT .....	F-5-1-6	ROD, ADJUSTING .....	F-10-21
O-RING, 6.5X1.5 .....	E-3-35	PLATE, SHIFT PIVOT .....	F-2-14	ROD, STEERING .....	F-10-26
O-RING, 6.9X1.45 .....	F-3-19	PLATE, SPEED SENSOR TUBE .....	F-10-16	ROLLER, 3X12.8 .....	F-5-25
O-RING, 7.45X3.61(NOK) .....	E-14-38	PLATE, SPRING SETTING .....	FOP-8-6-23	ROLLER, 3X12.8 .....	F-5-1-27
O-RING, 7.47X3.6 .....	E-14-37	PLATE, TDC PULSE .....	E-9-3	ROLLER, 5X8 .....	E-5-28
O-RING, 7.8X1.9(ARAI) .....	E-14-36	PLATE, WATER TUBE .....	E-6-13	ROLLER, CLICK .....	FOP-8-6-64
O-RING, 7.8X1.9(ARAI) .....	E-18-10-52	PLATE, WINKER BUZZER .....	FOP-6-19	ROTOR ASSY. ....	E-19-16
O-RING, 76.4X3.1 .....	E-4-13	PLATE, WINKER BUZZER .....	FOP-6-1-12	ROTOR COMP. ....	E-21-5
O-RING, 79.8X3.1 .....	E-4-14	PLATE, WINKER BUZZER .....	FOP-8-6-45	ROTOR, INNER OIL PUMP .....	E-5-8
O-RING, 9.5X1.5(HONDA KIKAKI) .....	E-9-10-25	PLUG, FUEL TUBE .....	F-9-8	ROTOR, OUTER OIL PUMP .....	E-5-9
O-RING, 9.5X1.9 .....	E-3-36	PLUG, INNER CONNECTOR .....	FOP-6-10	RUBBER B, STAND STOPPER .....	F-8-20-21
O-RING, 9.5X1.9 .....	E-4-16	PLUG, INNER CONNECTOR .....	FOP-6-1-5	RUBBER COMP., LOWER MOUNT .....	F-3-20-6
O-RING, 9.5X1.9 .....	E-9-10-26	PLUG, INNER CONNECTOR .....	FOP-8-6-35	RUBBER, FR. CARRIER CUSHION .....	E-14-22
O-RING, CHAIN CASE .....	E-9-10-23	PLUG, INNER CONNECTOR .....	FOP-11-3	RUBBER, MOUNT CASE SEAL .....	E-6-24
O-RING, THERMOSTAT COVER .....	E-6-21	PLUG, OUTER CONNECTOR .....	FOP-6-11	RUBBER, OIL PUMP .....	E-6-3
O-RING, WATER PUMP .....	F-4-32	PLUG, OUTER CONNECTOR .....	FOP-6-1-6	RUBBER, TROLLING CONTROL .....	FOP-12-2
O-RING, WATER PUMP .....	FOP-10-5	PLUG, OUTER CONNECTOR .....	FOP-8-6-36	<S>	
O-RING, WATER PUMP .....	FOP-10-1-10	PLUG, OUTER CONNECTOR .....	FOP-11-4	SCREEN COMP., FUEL STRAINER .....	E-18-10-41
<P>		PLUG, SPARK(IZFR6K-11) .....	E-20-	SCREEN, L. WATER .....	F-3-7
PACKING .....	E-21-16	PLUG, SPARK(KJ20DR-M11) .....	E-20-4	SCREEN, R. WATER .....	F-3-6
PACKING .....	F-11-43	PLUG, SPARK(SKJ20DR-M11) .....	E-20-	SCREW .....	E-19-9
PACKING, CHAIN CASE .....	E-9-10-24	PLUG, SPARK(ZFR6K-11) .....	E-20-	SCREW .....	E-19-12
PACKING, CYLINDER HEAD COVER .....	E-1-2	PLUG, TDC HOLE .....	E-9-20-16	SCREW SET .....	E-15-1
PACKING, DUAL .....	FOP-8-2-19	PLUG, VTC HOLE .....	E-9-20-11	SCREW SET, DRAIN .....	E-18-10-7
PACKING, ELECTRONIC AIR .....	E-14-21	PORT, IDLE EXHAUST .....	E-6-10	SCREW, 6X95 .....	FOP-8-6-52
PACKING, FLASH VALVE .....	E-6-20	PRIMER BULB .....	F-6-4	SCREW, FLAT, 5X12 .....	FOP-8-6-51
PACKING, INTAKE MANIFOLD .....	E-14-12	PRIMER BULB ASSY .....	F-6-1	SCREW, FLAT, 6X16 .....	E-5-23
PACKING, OIL PAN .....	E-6-2	PROPELLER COMP., THREE BLADES .....	F-5-11	SCREW, OVAL, 5X50 .....	F-3-21
PACKING, OIL PUMP BODY .....	E-5-3	PROPELLER COMP., THREE BLADES .....	F-5-	SCREW, PAN .....	E-18-10-21
PACKING, SINGLE .....	FOP-8-18	PROPELLER COMP., THREE BLADES .....	F-5-	SCREW, PAN, 4X10 .....	FOP-8-26
PACKING, THERMOSTAT COVER .....	E-9-10-7	PROPELLER COMP., THREE BLADES .....	F-5-	SCREW, PAN, 4X10 .....	FOP-8-2-29
PACKING, THERMOSTAT SPACER .....	E-9-10-8	PROPELLER COMP., THREE BLADES .....	F-5-	SCREW, PAN, 5X10 .....	FOP-8-23
PACKING, THROTTLE BODY .....	E-14-13	PROPELLER COMP., THREE BLADES .....	F-5-	SCREW, PAN, 5X10 .....	FOP-8-2-26

SCREW, PAN, 5X10.....	FOP-8-6-69	SHAFT ASSY., GEAR.....	E-21-14	STOPPER, TILT.....	F-10-25
SCREW, PAN, 5X12.....	E-18-1-7	SHAFT ASSY., GEAR.....	E-21-	STRAINER ASSY., VTC.....	E-9-20-12
SCREW, PAN, 5X16.....	FOP-8-22	SHAFT COMP. A, SHIFT.....	F-2-12	STRAINER COMP., FUEL.....	E-18-1-5
SCREW, PAN, 5X16.....	FOP-8-2-25	SHAFT COMP. B, SHIFT.....	F-2-18	STRAINER COMP., OIL.....	E-6-4
SCREW, PAN, 5X16.....	FOP-8-4-20	SHAFT COMP., FR. BALANCER.....	E-10-2	STRAINER, FUEL.....	E-18-1-6
SCREW, PAN, 5X18.....	E-15-16	SHAFT COMP., RR. BALANCER.....	E-10-3	STRAINER, FUEL PUMP.....	E-18-8
SCREW, PAN, 5X18.....	FOP-8-25	SHAFT, COVER OPEN.....	F-8-10-17	SUB HARNESS ASSY., POWER.....	FOP-8-19
SCREW, PAN, 5X18.....	FOP-8-2-28	SHAFT, EX. ROCKER.....	E-9-18	SUB HARNESS ASSY., POWER.....	FOP-8-2-20
SCREW, PAN, 5X20.....	FOP-8-24	SHAFT, FR. LOCK.....	F-8-10-18	SUB HARNESS ASSY., POWER.....	FOP-8-2-21
SCREW, PAN, 5X20.....	FOP-8-2-27	SHAFT, PROPELLER.....	F-5-9	SUB HARNESS ASSY., POWER.....	FOP-8-4-16
SCREW, PAN, 5X30.....	FOP-8-4-22	SHAFT, PROPELLER.....	F-5-1-9	SUSPENSION, STRAINER.....	E-18-9
SCREW, PAN, 5X40.....	FOP-6-22	SHAFT, ROCKER.....	E-9-17	SUSPENSION, STRAINER.....	E-18-1-10
SCREW, PAN, 5X40.....	FOP-6-1-15	SHAFT, THROTTLE BUTTON.....	FOP-8-4-9	SWITCH ASSY., COMBINATION.....	FOP-6-13
SCREW, PAN, 5X40.....	FOP-8-28	SHAFT, TILTING.....	F-10-22	SWITCH ASSY., COMBINATION.....	FOP-6-1-7
SCREW, PAN, 5X40.....	FOP-8-2-31	SHAFT, VERTICAL(L).....	F-4-13	SWITCH ASSY., COMBINATION.....	FOP-8-6-38
SCREW, PAN, 5X55.....	FOP-8-2-32	SHAFT, VERTICAL(XL).....	F-4-	SWITCH ASSY., EMERGENCY STOP.....	FOP-6-14
SCREW, PAN, 5X65.....	FOP-8-34	SHIFTER, CLUTCH.....	F-5-1	SWITCH ASSY., EMERGENCY STOP.....	FOP-6-1-8
SCREW, PAN, 5X65.....	FOP-8-2-39	SHIFTER, CLUTCH.....	F-5-1-1	SWITCH ASSY., EMERGENCY STOP.....	FOP-8-6-41
SCREW, PAN, 5X8.....	E-21-20	SHIM A, BEVEL(0.10).....	F-5-17	SWITCH ASSY., MAGNET.....	E-21-12
SCREW, PAN, 6X10.....	FOP-8-6-50	SHIM A, BEVEL(0.10).....	F-5-1-18	SWITCH ASSY., MAGNET.....	E-21-
SCREW, PAN, 6X18.....	E-4-18	SHIM A, GEAR(0.10).....	F-4-23	SWITCH ASSY., NEUTRAL.....	F-2-22
SCREW, PAN, 6X18.....	FOP-8-27	SHIM A, THRUST(0.10).....	F-5-1-19	SWITCH ASSY., POWER TILT.....	F-8-20-2
SCREW, PAN, 6X18.....	FOP-8-2-30	SHIM B, BEVEL(0.15).....	F-5-	SWITCH ASSY., POWER TRIM-TILT.....	FOP-8-20
SCREW, PAN, 6X22.....	E-21-	SHIM B, BEVEL(0.15).....	F-5-1-	SWITCH ASSY., POWER TRIM-TILT.....	FOP-8-2-22
SCREW, PAN, 6X22(SPECIAL).....	E-21-19	SHIM B, GEAR(0.15).....	F-4-	SWITCH ASSY., POWER TRIM-TILT.....	FOP-8-2-23
SCREW, PAN, 6X25.....	F-8-20-20	SHIM B, THRUST(0.15).....	F-5-1-	SWITCH ASSY., POWER TRIM-TILT.....	FOP-8-4-17
SCREW, PAN, 6X35.....	FOP-8-4-23	SHIM C, BEVEL(0.30).....	F-5-	SWITCH ASSY., POWER TRIM-TILT.....	FOP-8-6-39
SCREW, PAN, 6X8.....	F-3-20-13	SHIM C, BEVEL(0.30).....	F-5-1-	SWITCH ASSY., TROLLING CONTROL.....	FOP-12-1
SCREW, PAN, 6X8.....	F-10-37	SHIM C, GEAR(0.30).....	F-4-	<T>	
SCREW, PAN, 6X8.....	F-11-31	SHIM C, THRUST(0.30).....	F-5-1-	TAB, TRIM.....	F-3-8
SCREW, RIVET, 5X10.....	F-10-38	SHIM D, BEVEL(0.50).....	F-5-	TACHOMETER HOUR METER (BLACK).....	FOP-2-4
SCREW, TAPPET ADJUSTING.....	E-9-22	SHIM D, BEVEL(0.50).....	F-5-1-	TANK, OIL.....	F-11-25
SCREW, TAPPET ADJUSTING.....	E-9-23	SHIM D, GEAR(0.50).....	F-4-	TENSIONER ASSY., CAM CHAIN.....	E-9-9
SCREW, TAPPING, 4X12.....	F-8-13	SHIM D, THRUST(0.50).....	F-5-1-	TENSIONER COMP., BALANCER.....	E-10-6
SCREW, TAPPING, 5X10.....	FOP-8-6-71	SLIDER, SHIFT.....	F-5-4	TERMINAL, CABLE.....	FOP-8-16
SCREW, TAPPING, 5X12.....	FOP-8-6-72	SLIDER, SHIFT.....	F-5-1-4	TERMINAL, CABLE.....	FOP-8-2-17
SCREW, TAPPING, 5X20.....	E-13-9	SLINGER, OIL.....	F-4-14	TERMINAL, CABLE.....	FOP-8-4-12
SCREW, TAPPING, 5X25.....	FOP-8-6-74	SPACER KIT, REMOTE CONTROL BOX.....	FOP-8-2	THERMOSTAT ASSY.....	E-9-10-3
SCREW, TAPPING, 5X8.....	FOP-8-6-70	SPACER KIT, REMOTE CONTROL BOX.....	FOP-8-2-2	THERMOSTAT ASSY.....	E-9-10-4
SCREW, TAPPING, 6X16.....	FOP-8-6-73	SPACER, CABLE CLAMP.....	FOP-8-17	THROTTLE BODY ASSY.....	E-15-2
SCREW, TAPPING, 6X30.....	FOP-8-4-24	SPACER, CABLE CLAMP.....	FOP-8-2-18	TIE, CABLE.....	FOP-11-5
SCREW, TRUSS, 4X12.....	FOP-8-4-21	SPACER, CABLE CLAMP.....	FOP-8-4-13	TIE, CABLE(NATURAL)(2.4X92).....	FOP-6-12
SCREW, WASHER.....	E-18-10-22	SPACER, CABLE CLAMP.....	FOP-8-6-33	TIE, CABLE(NATURAL)(2.4X92).....	FOP-8-6-37
SCREW-WASHER.....	E-18-10-20	SPACER, CLICK SPRING.....	FOP-8-6-27	T-JOINT.....	E-6-7
SCREW-WASHER.....	E-19-10	SPACER, NEUTRAL SWITCH.....	FOP-8-6-30	T-JOINT.....	E-18-15
SCREW-WASHER, 4X25.....	E-19-11	SPACER, REMOTE CONTROL BOX.....	FOP-8-6-26	TRIM METER ASSY (BLACK).....	FOP-2-1
SCREW-WASHER, 5X15.....	F-7-20-9	SPACER, THERMOSTAT COVER.....	E-9-10-5	TRIM-TILT ASSY., POWER.....	F-11-10
SEAL A, COVER UNDER.....	F-8-20-11	SPRING COMP., CLICK.....	F-10-5	TUBE A, WATER RELIEF.....	E-4-10-4
SEAL A, VALVE STEM(ARAI).....	E-9-20-4	SPRING, ACCELERATOR WHEEL.....	FOP-8-6-21	TUBE B, AIR VENT.....	E-18-3
SEAL A, VALVE STEM(NOK).....	E-9-20-	SPRING, AIR FLOW TUBE.....	E-15-3	TUBE B, FUEL.....	E-18-10
SEAL B, COVER UNDER.....	F-8-20-12	SPRING, CHOKE RETURN.....	FOP-8-6-25	TUBE B, WATER RELIEF.....	E-4-10-5
SEAL B, VALVE STEM(ARAI).....	E-9-20-5	SPRING, CLICK.....	F-2-9	TUBE COMP. A, FUEL(FKM).....	F-9-1
SEAL B, VALVE STEM(NOK).....	E-9-20-	SPRING, CLICK ASSIST.....	F-10-6	TUBE COMP. B, FUEL.....	F-9-2
SEAL, ENGINE COVER.....	F-8-2	SPRING, COVER LOCK HOOK.....	F-8-10-14	TUBE COMP. C, AIR VENT.....	E-18-2
SEAL, FR. SEPARATE COVER.....	F-8-20-7	SPRING, COVER LOCK HOOK.....	F-8-10-15	TUBE COMP. C, FUEL.....	F-9-3
SEAL, PLUG HOLE.....	E-20-2	SPRING, EX. VALVE(GRAY).....	E-9-25	TUBE COMP. E, FUEL.....	F-9-5
SEAL, SPARK PLUG TUBE(NOK).....	E-1-3	SPRING, FLUSH VALVE.....	E-6-16	TUBE COMP. E, WATER.....	E-4-10-7
SEAL, WATER.....	F-11-42	SPRING, IN. VALVE(PINK).....	E-9-24	TUBE COMP., AIR VENT.....	E-18-4
SEAL, WATER(14X26X8).....	F-2-44	SPRING, LOCK ADJUSTER.....	F-8-5	TUBE COMP., WATER RELIEF.....	E-4-10-3
SEAL, WATER, 12X21X6.....	F-4-30	SPRING, LOCK LEVER RETURN.....	F-8-10-16	TUBE D, FUEL.....	E-18-7
SEAL, WATER, 22X35X7.....	E-6-43	SPRING, MOTOR.....	F-11-7	TUBE D, FUEL.....	F-9-4
SEAL, WATER, 23X36X6.....	F-4-29	SPRING, NEUTRAL LOCK ARM.....	FOP-8-4-7	TUBE F, FUEL.....	E-18-10-40
SEAL, WATER, 23X36X8.....	F-4-28	SPRING, RELIEF VALVE.....	E-5-6	TUBE F, WATER.....	E-18-14
SEAL, WATER, 30X45X7.....	F-5-26	SPRING, REMOTE CONTROL HANDLE.....	FOP-8-6-7	TUBE G, WATER.....	E-18-16
SEAL, WATER, 30X45X7.....	F-5-1-28	SPRING, SET.....	E-18-10-42	TUBE KIT, SPEED SENSOR.....	F-10-2
SEAT, VALVE SPRING.....	E-9-27	SPRING, SHIFT.....	F-5-5	TUBE, 12X740.....	E-15-25
SEAT, WATER MOUTH.....	F-9-11	SPRING, SHIFT.....	F-5-1-5	TUBE, 5X140.....	F-3-22
SENSOR ASSY., AIR TEMP.....	E-15-13	SPRING, SHIFT CLICK.....	FOP-8-6-24	TUBE, 5X270.....	F-3-
SENSOR ASSY., CRANK.....	E-9-10-13	SPRING, SHIFT ROD.....	F-4-10	TUBE, 5X950.....	F-10-65
SENSOR ASSY., KNOCK.....	E-3-12	SPRING, SILENCER DUCT GROMMET.....	E-15-8	TUBE, 7X120.....	E-4-10-14
SENSOR ASSY., MAP.....	E-15-11	SPROCKET COMP., CHAIN DRIVE.....	E-7-12	TUBE, 7X160.....	E-6-51
SENSOR ASSY., TDC.....	E-9-20-15	SPROCKET, CAM CHAIN DRIVEN.....	E-9-6	TUBE, 7X200.....	E-6-52
SENSOR ASSY., TRIM ANGLE.....	F-10-8	SPROCKET, CAM CHAIN DRIVEN IN.....	E-9-7	TUBE, 7X40.....	E-6-50
SENSOR ASSY., WATER.....	E-3-15	SPROCKET, DRIVEN(17T).....	E-10-4	TUBE, 7X75.....	E-4-10-12
SENSOR ASSY., WATER.....	E-4-7	STAY A, PLATE.....	E-18-10-3	TUBE, 7X90.....	E-4-10-13
SENSOR ASSY., WATER.....	E-9-10-11	STAY, A.C. GENERATOR.....	E-19-18	TUBE, BYPASS SOLENOID.....	E-14-18
SENSOR ASSY., WATER.....	E-9-10-12	STAY, FUEL STRAINER.....	E-18-1-9	TUBE, DIAPHRAGM.....	E-14-17
SENSOR, LAF.....	E-4-6	STAY, PLATE.....	E-18-10-36	TUBE, FUEL, 3.5X430.....	E-18-31
SENSOR, OIL PRESSURE.....	E-3-16	STAY, POWER TILT SWITCH.....	F-8-20-3	TUBE, FUEL, 8X300.....	F-9-14
SEPARATOR ASSY., VAPOR.....	E-18-10-33	STAY, VAPOR SEPARATOR.....	E-18-10-38	TUBE, OIL.....	E-4-10-1
SEPARATOR ASSY., WATER.....	E-18-1-2	STOPPER SET, SLEEVE.....	E-21-8	TUBE, PRESSURE REGULATOR.....	E-14-7
SHAFT ASSY., CLUTCH.....	E-21-13	STOPPER SET, SLEEVE.....	E-21-	TUBE, SPEED SENSOR.....	F-10-10
SHAFT ASSY., CLUTCH.....	E-21-	STOPPER(TOOL).....	E-9-10	TUBE, SPIRAL.....	F-10-9

TUBE, SPIRAL .....	F-10-67	WASHER, WAVE, 10MM .....	F-8-10-27
TUBE, VINYL, 4X7X160 .....	E-15-24	WASHER, WAVE, 26MM .....	F-10-47
TUBE, WATER RELIEF .....	E-6-14	WASHER, WAVE, 40MM .....	F-10-46
TUBE, WATER(L) .....	F-4-7	WHEEL, ACCELERATOR.....	FOP-8-6-20
TUBE, WATER(XL) .....	F-4-	WHEEL, CONTROL .....	FOP-8-6-13
<V>		WIRE, LEAD(1.5X116MM) .....	F-11-8
VALVE ASSY., AIR BYPASS .....	E-14-16	WIRE, LEAD(1.5X137MM) .....	F-3-20-4
VALVE ASSY., ELECTRONIC AIR .....	E-14-20	WRENCH, EYE, 19MM .....	F-13-11
VALVE ASSY., RELIEF .....	E-6-17	WRENCH, HEX, 6MM .....	F-13-6
VALVE ASSY., SPOOL.....	E-9-20-8	WRENCH, PLUG.....	F-13-5
VALVE COMP., MANUAL .....	F-11-21	<Y>	
VALVE COMP., RESERVOIR.....	F-11-22	YOKE ASSY.....	F-11-6
VALVE SET, FLOAT .....	E-18-10-1	YOKE COMP. ....	E-21-4
VALVE, CHECK.....	E-18-17		
VALVE, EX.....	E-9-21		
VALVE, FLASH .....	E-6-18		
VALVE, IN.....	E-9-20		
VALVE, RELIEF .....	E-5-5		
<W>			
WASHER .....	F-2-35		
WASHER B, THRUST, 14MM .....	F-2-33		
WASHER, 10MM .....	F-10-49		
WASHER, 26MM .....	F-3-20-15		
WASHER, 28MM .....	FOP-8-6-61		
WASHER, 6MM .....	FOP-8-6-59		
WASHER, DRAIN PLUG, 12MM.....	E-6-39		
WASHER, DRAIN PLUG, 20MM.....	E-5-24		
WASHER, DRAIN PLUG, 20MM.....	E-9-20-26		
WASHER, HEAD COVER .....	E-1-7		
WASHER, LOCK, 5MM .....	FOP-8-30		
WASHER, LOCK, 5MM .....	FOP-8-2-35		
WASHER, LOCK, 5MM .....	FOP-8-4-26		
WASHER, LOCK, 6MM .....	FOP-8-32		
WASHER, LOCK, 6MM .....	FOP-8-2-37		
WASHER, PIVOT .....	F-2-7		
WASHER, PIVOT .....	F-4-1		
WASHER, PLAIN .....	E-18-10-24		
WASHER, PLAIN .....	E-18-10-25		
WASHER, PLAIN, 10MM .....	F-5-18		
WASHER, PLAIN, 10MM .....	F-5-1-20		
WASHER, PLAIN, 10MM .....	F-8-10-26		
WASHER, PLAIN, 10MM .....	F-10-50		
WASHER, PLAIN, 10MM .....	F-10-54		
WASHER, PLAIN, 12MM .....	E-6-38		
WASHER, PLAIN, 12MM .....	F-2-34		
WASHER, PLAIN, 12MM .....	F-3-20-16		
WASHER, PLAIN, 12MM .....	F-4-22		
WASHER, PLAIN, 12MM .....	F-8-11		
WASHER, PLAIN, 12MM .....	F-10-51		
WASHER, PLAIN, 12MM .....	F-10-52		
WASHER, PLAIN, 12MM .....	F-10-53		
WASHER, PLAIN, 4MM .....	FOP-8-6-55		
WASHER, PLAIN, 5MM .....	FOP-6-25		
WASHER, PLAIN, 5MM .....	FOP-6-1-18		
WASHER, PLAIN, 5MM .....	FOP-8-31		
WASHER, PLAIN, 5MM .....	FOP-8-33		
WASHER, PLAIN, 5MM .....	FOP-8-2-36		
WASHER, PLAIN, 5MM .....	FOP-8-2-38		
WASHER, PLAIN, 5MM .....	FOP-8-6-56		
WASHER, PLAIN, 5MM .....	FOP-8-6-57		
WASHER, PLAIN, 6MM .....	F-2-36		
WASHER, PLAIN, 6MM .....	F-8-10		
WASHER, PLAIN, 6MM .....	FOP-8-4-27		
WASHER, PLAIN, 6MM .....	FOP-8-6-58		
WASHER, PLAIN, 8MM .....	F-2-37		
WASHER, PLAIN, 8MM .....	F-7-10-14		
WASHER, PLAIN, 8MM .....	F-8-10-25		
WASHER, PLAIN, 8MM .....	F-8-10-28		
WASHER, PLAIN, 8MM .....	FOP-8-6-60		
WASHER, PROPELLER .....	F-5-16		
WASHER, PROPELLER .....	F-5-1-17		
WASHER, PROPELLER THRUST.....	F-5-14		
WASHER, PROPELLER THRUST.....	F-5-1-15		
WASHER, SEALING, 28MM .....	E-3-29		
WASHER, SEALING, 6MM.....	E-18-10-50		
WASHER, SPRING, 4MM.....	FOP-12-9		
WASHER, SPRING, 5MM.....	FOP-6-26		
WASHER, SPRING, 5MM.....	FOP-6-1-19		
WASHER, THRUST .....	E-7-10		
WASHER, THRUST .....	E-9-19		
WASHER, THRUST BEARING .....	F-5-15		
WASHER, THRUST BEARING .....	F-5-1-16		
WASHER, THRUST, 34MM .....	F-10-48		

# INDEX (Parts Number)

332-70201-0	F-6-8	HCO-94301-08100	E-10-13	HMG9-35701-950	F-8-10-1	HPNA-14620-040	E-9-14
3C7-70217-0	F-6-5	HCO-94301-10120	E-7-17	HMG9-35701-950	FOP-8-6-40	HPNA-14631-000	E-9-17
3C7-70220-1	F-6-2	HCO-94301-10160	E-5-25	HMJ0-91301-003	E-14-36	HPNA-14711-000	E-9-20
3C7-70224-1	F-6-3	HCO-94301-10160	E-6-48	HMJ0-91301-003	E-18-10-52	HPNA-14744-004	E-9-23
3FF-70200-4	F-6-1	HCO-94301-10160	E-9-20-27	HMM4-90105-000	FOP-8-6-50	HPNA-14762-003	E-9-25
3GF-70211-1	F-6-4	HCO-94301-12160	E-10-14	HMM8-90501-610	F-8-10-25	HPNA-14820-013	E-9-20-7
3GF-70240-1	F-6-7	HCO-94301-14200	E-5-26	HMM8-90502-610	F-8-10-26	HPNA-17055-004	E-14-11
3GF-70241-1	F-6-6	HCO-94301-14200	E-6-49	HMN5-17195-000	E-6-7	HPNA-90003-000	E-9-29
3PU-72537-0	FOP-2-6	HCO-94301-14200	E-9-20-28	HMR5-16966-000	F-9-7	HPNA-90004-000	E-10-9
3PV-72571-0	FOP-2-1	HCO-94305-25203	F-10-64	HMR5-16966-000	F-9-15	HPNA-90005-003	E-9-20-17
3PV-72637-0	FOP-2-4	HCO-94510-14000	F-5-28	HMT8-18334-770	FOP-6-3	HPNA-90006-003	E-3-20
H121-51640-730	E-14-22	HCO-94510-14000	F-5-1-30	HMT8-18334-770	FOP-6-1-2	HPNA-90011-003	E-9-20-18
H341-38403-672	FOP-6-19	HCO-94540-03029	FOP-8-6-77	HMV1-16959-000	E-4-10-2	HPNA-90031-004	E-10-11
H341-38403-672	FOP-6-1-12	HCO-94540-04029	F-2-48	HMY5-91005-601	F-5-20	HPNA-90032-000	E-9-30
H341-38403-672	FOP-8-6-45	HCO-94540-04029	FOP-8-6-78	HMY5-91005-601	F-5-1-22	HPNA-90042-003	E-9-31
H460-89221-840	F-13-6	HCO-94540-06029	F-2-49	HMZ5-16952-000	E-18-10	HPNA-90703-300	E-9-34
H538-89102-000	F-13-1	HCO-94540-06029	F-8-10-29	HP01-91212-003	E-5-21	HPNA-90704-000	E-7-16
H538-89103-000	F-13-2	HCO-94540-06029	FOP-8-36	HP0X-91321-003	F-2-45	HPNA-90715-000	E-3-32
H723-90472-000	F-4-22	HCO-94540-06029	FOP-8-2-41	HP2A-37881-000	E-15-14	HPNA-91214-014	E-3-33
H750-90628-000	F-10-56	HCO-94540-06029	FOP-8-4-28	HP5A-13115-000	E-7-4	HPNA-91302-003	E-14-38
H759-16911-003	E-18-8	HCO-94540-07029	FOP-8-6-79	HP64-31141-003	E-19-6	HPNA-91302-004	E-9-10-23
H763-75538-C01	F-2-26	HCO-94540-10019	F-4-35	HP8A-13204-A01	E-7-5	HPNA-91307-003	E-3-36
H763-90681-A01	F-10-58	HCO-94540-12029	F-2-50	HPA9-91317-003	E-18-26	HPNA-91307-003	E-4-16
H800-91303-000	E-6-44	HCO-94540-15029	F-11-45	HPC6-15233-000	E-5-7	HPNA-91307-003	E-9-10-26
H805-91301-000	E-3-34	HCO-95001-35430-40	E-18-31	HPC6-90715-000	E-3-31	HPNA-91333-003	E-9-10-27
H881-90105-000	F-4-17	HCO-95001-80300-00	F-9-14	HPC6-91324-000	E-6-46	HPNA-91333-003	E-9-20-25
H881-90110-000	F-10-36	HCO-95003-07016-31	E-15-24	HPCX-12342-004	E-1-3	HPNB-37500-003	E-9-10-13
H921-15611-000	E-3-11	HCO-95005-12740-20	E-15-25	HPCX-14744-014	E-9-22	HPNB-37510-003	E-9-20-15
H921-17936-000	F-2-7	HCO-95005-50140-30	F-3-22	HPCX-90017-013	E-7-15	HPNC-91212-004	E-9-10-22
H921-17936-000	F-4-1	HCO-95005-50270-30	F-3-	HPD1-31138-004	E-19-5	HPP4-90009-E01	E-18-10-45
H921-90302-000	F-8-20-16	HCO-95005-50950-30	F-10-65	HPD1-31142-004	E-19-7	HPPA-13210-000	E-7-6
H921-90302-000	FOP-6-23	HCO-95005-70040-30	E-6-50	HPD1-31148-004	E-19-11	HPPA-13310-000	E-7-8
H921-90302-000	FOP-6-1-16	HCO-95005-70075-30	E-4-10-12	HPD1-90231-014	E-19-30	HPPA-14520-003	E-9-11
H921-90302-000	FOP-8-6-53	HCO-95005-70090-30	E-4-10-13	HPD6-90430-003	E-18-10-50	HPPA-14530-003	E-9-12
H921-90504-010	F-8-10	HCO-95005-70120-30	E-4-10-14	HPE0-15231-000	E-5-5	HPR3-91319-003	E-3-37
H921-90504-010	FOP-8-6-58	HCO-95005-70160-30	E-6-51	HPE0-90703-000	E-3-30	HPRA-11106-013	E-3-3
H921-90511-000	F-10-50	HCO-95005-70200-30	E-6-52	HPE9-31145-941	E-19-8	HPRA-90401-000	E-3-29
H921-90512-010	FOP-8-6-59	HCO-95011-62000	F-8-20-21	HPE9-31152-942	E-19-13	HPRA-15290-000	E-3-9
H921-90518-000	F-2-37	HCO-95701-06014-08	E-10-15	HPFB-30522-007	E-20-2	HPRB-14721-A00	E-9-21
H921-90518-000	F-8-10-28	HCO-95701-06018-09	E-6-53	HPG6-15232-000	E-5-6	HPRB-15280-A00	E-3-8
H921-90518-000	FOP-8-6-60	HCO-95701-06020-08	E-9-36	HPGK-37835-A01	E-15-12	HPSA-36454-003	E-14-19
H921-90602-000	F-10-55	HCO-95701-06020-08	E-9-20-29	HPH1-90015-013	E-5-16	HPT0-14775-000	E-9-27
H952-32901-770	FOP-6-12	HCO-95701-06030-08	E-9-37	HPH3-90011-000	E-5-15	HPT0-31147-003	E-19-10
H952-32901-770	FOP-8-6-37	HCO-95701-06032-08	E-9-20-30	HPJ7-31111-013	E-19-3	HPT0-90206-004	E-9-33
HP58-90428-000	F-2-33	HCO-95701-08032-08	E-5-27	HPJ7-31114-013	E-19-4	HPT2-91005-N01	F-5-21
HCO-92101-04020-4J	FOP-12-7	HCO-95701-08050-08	E-10-16	HPJ7-31146-003	E-19-9	HPT2-91005-N01	F-5-1-23
HCO-92101-05016-4J	FOP-8-6-68	HCO-95701-08075-08	E-10-17	HPJ7-91309-010	E-6-45	HPY3-17249-000	E-15-3
HCO-92101-06050-4J	F-3-20	HCO-95701-08090-08	E-9-20-31	HPK1-32742-003	F-7-30-3	HPY3-31215-004	E-21-3
HCO-93500-05010-4J	FOP-8-6-69	HCO-95701-08110-08	E-9-20-32	HPK2-91307-005	E-9-10-25	HPY3-31218-004	E-21-6
HCO-93500-05065-4J	FOP-8-34	HCO-95701-10105-08	E-10-18	HPLC-37880-004	E-15-13	HPZ1-12210-003	E-9-20-4
HCO-93500-05065-4J	FOP-8-2-39	HCO-95701-10110-09	E-6-54	HPLC-91301-000	E-14-37	HPZ1-12210-004	E-9-20-
HCO-93500-06018-4J	E-4-18	HCO-95801-08035-09	F-10-66	HPM3-90206-004	E-9-32	HPZ1-12211-003	E-9-20-5
HCO-93500-06025-4J	F-8-20-20	HCO-96211-07000	F-5-29	HPNA-11106-300	E-3-2	HPZ1-12211-004	E-9-20-
HCO-93600-06016-0A	E-5-23	HCO-96211-07000	F-5-1-31	HPNA-11135-000	E-3-4	HPZ1-31105-003	E-19-2
HCO-93700-05050-4J	F-3-21	HCO-96211-09000	F-5-30	HPNA-12204-305	E-9-20-2	HPZ1-31149-003	E-19-12
HCO-93901-250J0	FOP-8-6-70	HCO-96211-09000	F-5-1-32	HPNA-12205-305	E-9-20-3	HPZ1-31153-003	E-19-14
HCO-93901-251J0	FOP-8-6-71	HCO-96220-50080	E-5-28	HPNA-12341-000	E-1-2	HR40-14401-A01	E-9-8
HCO-93901-252J0	FOP-8-6-72	HCO-96300-06025-00	E-10-19	HPNA-13111-010	E-7-3	HR40-14633-A00	E-9-18
HCO-93903-254G0	E-13-9	HCO-96300-06032-00	E-10-20	HPNA-13321-003	E-7-9	HR40-15115-A01	E-10-8
HCO-93903-262J0	FOP-8-6-73	HCO-9807B-5615P	E-20-4	HPNA-13322-003	E-7-	HRAA-13620-A02	E-7-12
HCO-93905-255J0	FOP-8-6-74	HCO-9807B-5615W	E-20-	HPNA-13323-003	E-7-	HRAA-14624-A00	E-9-16
HCO-93913-142J0	F-8-13	HCO-9807B-5617P	E-20-	HPNA-13324-003	E-7-	HRAA-14647-A00	E-9-19
HCO-94001-04490-05	FOP-12-8	HCO-9807B-5617W	E-20-	HPNA-13325-003	E-7-	HRAA-14765-A00	E-9-26
HCO-94001-05490-05	F-2-47	HCO-98200-41000	F-7-20-10	HPNA-13326-003	E-7-	HRAA-15815-A02	E-9-20-9
HCO-94001-05490-05	FOP-8-35	HCO-98200-41500	F-7-20-11	HPNA-13341-003	E-7-11	HRAA-15845-A01	E-9-20-13
HCO-94001-05490-05	FOP-8-2-40	HCO-98200-43000	F-7-20-12	HPNA-13342-003	E-7-	HRAD-13410-010	E-10-2
HCO-94001-06080-05	E-19-31	HCO-99006-19000	F-13-11	HPNA-13343-003	E-7-	HRAD-13420-010	E-10-3
HCO-94001-06490-05	FOP-8-6-75	HCO-99008-02300	F-13-12	HPNA-13344-003	E-7-	HRGM-14781-A01	E-9-28
HCO-94001-12490-05	F-10-63	HGE1-17357-670	F-10-4	HPNA-13345-003	E-7-	HRNA-37260-A01	E-3-16
HCO-94002-05490-05	FOP-8-6-76	HGEV-90650-003	E-14-34	HPNA-13346-003	E-7-	HRNA-37830-A01	E-15-11
HCO-94002-06490-05	F-8-14	HGHB-16163-610	E-18-1	HPNA-13432-000	E-10-4	HRRA-30520-007	E-20-1
HCO-94103-05400	FOP-6-25	HHC4-90653-900	F-8-20-17	HPNA-13441-004	E-10-5	HRTA-15400-004	E-5-10
HCO-94103-05400	FOP-6-1-18	HHN0-91305-A00	E-4-15	HPNA-13450-004	E-10-6	HRWC-14540-A02	E-9-13
HCO-94109-20000	E-5-24	HKJ2-90683-003	F-8-20-18	HPNA-13460-004	E-10-7	HS0A-91541-003	E-3-38
HCO-94109-20000	E-9-20-26	HKM3-32161-003	F-3-2	HPNA-13622-003	E-7-13	HS0A-91541-003	F-7-7
HCO-94111-04500	FOP-12-9	HKM3-32161-003	F-7-2	HPNA-14114-003	E-9-3	HS0A-91541-003	F-7-10-17
HCO-94111-05400	FOP-6-26	HKM3-32161-003	F-10-7	HPNA-14115-000	E-9-4	HS0A-90683-003	E-18-1-15
HCO-94111-05400	FOP-6-1-19	HKV7-17368-671	E-18-12	HPNA-14210-000	E-9-6	HSB2-90620-003	F-7-10-15
HCO-94301-06100	E-6-47	HMB0-91359-000	F-4-33	HPNA-14511-003	E-9-10	HSB2-90687-003	E-14-35

HSB2-90687-003 . . . . .	F-7-10-16	HZV5-32823-003 . . . . .	FOP-6-1-5	HZW1-24327-000 . . . . .	F-2-11	HZW1-91554-000 . . . . .	E-18-10-53
HSB6-91475-000 . . . . .	FOP-8-6-65	HZV5-32823-003 . . . . .	FOP-8-6-35	HZW1-31229-004 . . . . .	E-21-8	HZW1-91557-701 . . . . .	F-11-44
HSC2-90649-003 . . . . .	FOP-6-24	HZV5-32823-003 . . . . .	FOP-11-3	HZW1-31247-004 . . . . .	E-21-15	HZW2-90003-000 . . . . .	E-20-10-4
HSC2-90649-003 . . . . .	FOP-6-1-17	HZV5-32824-003 . . . . .	FOP-6-11	HZW1-31249-004 . . . . .	E-21-16	HZW2-90301-F00 . . . . .	E-14-33
HSDA-39794-004 . . . . .	F-7-20-5	HZV5-32824-003 . . . . .	FOP-6-1-6	HZW1-31250-004 . . . . .	E-21-17	HZW4-90108-000 . . . . .	FOP-8-6-51
HSE0-53740-953 . . . . .	E-18-18	HZV5-32824-003 . . . . .	FOP-8-6-36	HZW1-31261-004 . . . . .	E-21-18	HZW4-90126-000 . . . . .	E-14-30
HSE0-91547-003 . . . . .	E-18-27	HZV5-32824-003 . . . . .	FOP-11-4	HZW1-38551-000 . . . . .	F-7-10-8	HZW4-90151-000 . . . . .	E-14-31
HSF1-91595-003 . . . . .	E-15-23	HZV5-35370-823 . . . . .	FOP-8-6-39	HZW1-40107-700 . . . . .	F-8-10-3	HZW4-90156-000 . . . . .	E-3-26
HSH3-91599-A32 . . . . .	E-18-30	HZV5-36104-821 . . . . .	F-10-67	HZW1-40204-000 . . . . .	F-4-12	HZW4-90162-000 . . . . .	E-3-27
HSM4-32134-003 . . . . .	F-7-30-2	HZV5-36136-821 . . . . .	F-11-7	HZW1-40210-710 . . . . .	F-3-20-3	HZW4-90162-000 . . . . .	E-9-10-21
HSMA-91558-003 . . . . .	E-18-29	HZV5-36180-033 . . . . .	FOP-6-14	HZW1-41102-800 . . . . .	F-3-4	HZW4-90163-000 . . . . .	E-19-28
HSP0-91546-A01 . . . . .	E-9-10-28	HZV5-36180-033 . . . . .	FOP-6-1-8	HZW1-41109-800 . . . . .	F-3-9	HZW4-90164-000 . . . . .	E-21-21
HSP0-91546-A01 . . . . .	E-13-7	HZV5-36180-033 . . . . .	FOP-8-6-41	HZW1-41116-800 . . . . .	F-4-14	HZW4-90170-000 . . . . .	E-4-11
HSTK-91540-003 . . . . .	FOP-11-6	HZV5-38410-003 . . . . .	FOP-6-20	HZW1-50111-010ZC . . . . .	F-3-20-5	HZW4-90306-003 . . . . .	F-10-44
HSV1-91549-L01 . . . . .	F-2-46	HZV5-38410-003 . . . . .	FOP-6-1-13	HZW1-50156-010 . . . . .	F-3-20-7	HZW4-90401-000 . . . . .	FOP-8-6-55
HSV4-91540-003 . . . . .	E-4-17	HZV5-38410-003 . . . . .	FOP-8-6-46	HZW1-50161-020ZC . . . . .	F-3-20-8	HZW4-90402-000 . . . . .	FOP-8-6-56
HSZ5-91531-003 . . . . .	E-13-6	HZV5-40102-000 . . . . .	E-13-4	HZW1-50201-040ZC . . . . .	F-10-15	HZW4-91301-003 . . . . .	F-3-19
HVD6-91360-003 . . . . .	E-5-22	HZV5-40102-000 . . . . .	E-15-15	HZW1-50214-000 . . . . .	F-10-18	HZW5-06241-U00 . . . . .	FOP-8-2
HVMO-16965-771 . . . . .	E-18-11	HZV5-41171-000 . . . . .	F-3-10	HZW1-50301-070ZC . . . . .	F-10-19	HZW5-06241-U10 . . . . .	FOP-8-2-2
HVMO-16965-771 . . . . .	F-7-30-1	HZV5-41172-000 . . . . .	F-3-11	HZW1-50311-070ZC . . . . .	F-10-20	HZW5-06900-U00 . . . . .	FOP-9-1
HVMO-46391-003 . . . . .	F-2-24	HZV5-50214-003 . . . . .	F-11-9	HZW1-50527-000 . . . . .	F-10-24	HZW5-15113-000 . . . . .	E-6-3
HZB5-90626-730 . . . . .	F-10-69	HZV5-50522-000 . . . . .	F-10-23	HZW1-50529-000 . . . . .	F-10-25	HZW5-15331-003 . . . . .	E-5-8
HZC0-63515-700 . . . . .	F-8-10-21	HZV5-56117-821 . . . . .	F-11-17	HZW1-53238-010 . . . . .	F-10-26	HZW5-15341-003 . . . . .	E-5-9
HZE2-16731-003 . . . . .	E-18-1-1	HZV5-56118-820 . . . . .	F-10-68	HZW1-56110-701 . . . . .	F-11-12	HZW5-16081-010 . . . . .	E-18-10-20
HZE2-90601-000 . . . . .	E-6-39	HZV5-56513-000 . . . . .	F-11-23	HZW1-56113-701 . . . . .	F-11-13	HZW5-16086-000 . . . . .	E-18-10-23
HZV0-90604-000 . . . . .	E-18-24	HZV5-90081-010 . . . . .	E-5-19	HZW1-56115-305 . . . . .	F-11-14	HZW5-16087-000 . . . . .	E-18-10-24
HZV0-90604-000 . . . . .	E-18-1-14	HZV5-90119-000 . . . . .	F-3-20-13	HZW1-56116-701 . . . . .	F-11-16	HZW5-16708-003 . . . . .	E-18-10-28
HZV0-90604-000 . . . . .	F-9-12	HZV5-90119-000 . . . . .	F-10-37	HZW1-56120-305 . . . . .	F-11-18	HZW5-16715-023 . . . . .	E-18-10-29
HZV1-24210-010 . . . . .	F-10-5	HZV5-90119-000 . . . . .	F-11-31	HZW1-56130-702 . . . . .	F-11-20	HZW5-16733-000 . . . . .	E-18-10-34
HZV1-87538-C23 . . . . .	F-12-11	HZV5-90125-000 . . . . .	FOP-8-6-52	HZW1-56180-701 . . . . .	F-11-22	HZW5-16735-003 . . . . .	E-18-10-37
HZV1-90127-010 . . . . .	E-15-20	HZV5-90127-003 . . . . .	F-10-38	HZW1-56516-000 . . . . .	F-10-28	HZW5-16915-000 . . . . .	E-18-9
HZV3-90601-030 . . . . .	E-15-21	HZV5-90131-000 . . . . .	E-6-37	HZW1-56532-000 . . . . .	F-11-24	HZW5-24810-U01 . . . . .	FOP-8-3
HZV4-17704-010 . . . . .	F-9-16	HZV5-90302-003 . . . . .	F-2-32	HZW1-56539-000 . . . . .	F-10-29	HZW5-24810-U01 . . . . .	FOP-8-2-3
HZV4-24221-010 . . . . .	F-10-6	HZV5-90304-013 . . . . .	F-10-41	HZW1-56851-703 . . . . .	F-11-25	HZW5-24810-U11 . . . . .	FOP-8-2-4
HZV4-36182-651 . . . . .	FOP-6-15	HZV5-90307-003 . . . . .	F-10-45	HZW1-56860-701 . . . . .	F-11-26	HZW5-24811-U01 . . . . .	FOP-8-4
HZV4-36182-651 . . . . .	FOP-6-1-9	HZV5-90501-000 . . . . .	F-10-46	HZW1-90013-000 . . . . .	E-13-5	HZW5-24811-U01 . . . . .	FOP-8-2-5
HZV4-36182-651 . . . . .	FOP-8-6-42	HZV5-90502-000 . . . . .	F-10-47	HZW1-90013-000 . . . . .	E-15-17	HZW5-24812-U01 . . . . .	FOP-8-5
HZV4-36187-652 . . . . .	FOP-6-16	HZV5-90504-000 . . . . .	F-10-48	HZW1-90014-000 . . . . .	E-14-23	HZW5-24812-U01 . . . . .	FOP-8-2-6
HZV4-36187-652 . . . . .	FOP-6-1-10	HZV5-90552-000 . . . . .	F-10-51	HZW1-90014-000 . . . . .	E-18-20	HZW5-24813-U01 . . . . .	FOP-8-6
HZV4-36187-652 . . . . .	FOP-8-6-43	HZV5-90557-000 . . . . .	FOP-8-6-61	HZW1-90014-000 . . . . .	E-18-10-46	HZW5-24813-U01 . . . . .	FOP-8-2-7
HZV4-90302-000 . . . . .	F-3-17	HZV5-90559-000 . . . . .	E-6-38	HZW1-90102-000 . . . . .	F-10-31	HZW5-24813-U21 . . . . .	FOP-8-2-8
HZV4-90304-000 . . . . .	FOP-8-6-54	HZV5-90559-000 . . . . .	F-10-52	HZW1-90105-000 . . . . .	F-10-33	HZW5-24814-U01 . . . . .	FOP-8-7
HZV4-90502-000 . . . . .	FOP-8-31	HZV5-90559-000 . . . . .	F-10-53	HZW1-90106-004 . . . . .	E-21-19	HZW5-24814-U01 . . . . .	FOP-8-2-9
HZV4-90502-000 . . . . .	FOP-8-2-36	HZV5-90563-000 . . . . .	F-5-18	HZW1-90107-004 . . . . .	E-21-20	HZW5-24815-U01 . . . . .	FOP-8-8
HZV4-90502-000 . . . . .	FOP-8-6-57	HZV5-90563-000 . . . . .	F-5-1-20	HZW1-90108-000 . . . . .	F-10-35	HZW5-24816-U01 . . . . .	FOP-8-9
HZV4-90512-000 . . . . .	F-2-36	HZV5-90563-000 . . . . .	F-10-54	HZW1-90113-702 . . . . .	F-11-27	HZW5-24816-U01 . . . . .	FOP-8-2-10
HZV4-90514-000 . . . . .	F-10-49	HZV5-90651-000 . . . . .	F-10-57	HZW1-90114-702 . . . . .	F-11-28	HZW5-24816-U01 . . . . .	FOP-8-4-8
HZV5-12155-000 . . . . .	E-4-1	HZV5-90751-000 . . . . .	FOP-8-6-62	HZW1-90115-702 . . . . .	F-11-29	HZW5-24817-U01 . . . . .	FOP-8-10
HZV5-16881-000 . . . . .	E-18-7	HZV5-90756-000 . . . . .	F-3-18	HZW1-90116-702 . . . . .	F-11-30	HZW5-24817-U01 . . . . .	FOP-8-2-11
HZV5-17838-000 . . . . .	F-2-1	HZV5-90756-000 . . . . .	F-3-20-18	HZW1-90203-000 . . . . .	F-7-10-13	HZW5-24818-U01 . . . . .	FOP-8-11
HZV5-24811-010 . . . . .	FOP-8-6-2	HZV5-90756-000 . . . . .	F-4-25	HZW1-90242-000 . . . . .	F-4-20	HZW5-24818-U01 . . . . .	FOP-8-2-12
HZV5-24812-000 . . . . .	FOP-8-6-3	HZV5-90772-000 . . . . .	FOP-8-6-63	HZW1-90301-800 . . . . .	F-5-13	HZW5-24819-U01 . . . . .	FOP-8-12
HZV5-24813-000 . . . . .	FOP-8-6-4	HZV5-91151-000 . . . . .	FOP-8-6-64	HZW1-90301-800 . . . . .	F-5-1-14	HZW5-24819-U01 . . . . .	FOP-8-2-13
HZV5-24814-010 . . . . .	FOP-8-6-5	HZV5-91203-821 . . . . .	F-11-33	HZW1-90304-013 . . . . .	F-10-42	HZW5-24825-U01 . . . . .	FOP-8-14
HZV5-24815-010 . . . . .	FOP-8-6-6	HZV5-91256-003 . . . . .	F-10-60	HZW1-90501-710 . . . . .	F-3-20-15	HZW5-24825-U01 . . . . .	FOP-8-15
HZV5-24816-000 . . . . .	FOP-8-6-7	HZV5-91302-821 . . . . .	F-11-35	HZW1-90518-800 . . . . .	F-4-23	HZW5-24826-U01 . . . . .	FOP-8-15
HZV5-24817-000 . . . . .	FOP-8-6-8	HZV5-91316-821 . . . . .	F-11-36	HZW1-90519-800 . . . . .	F-4	HZW5-24826-U01 . . . . .	FOP-8-2-16
HZV5-24818-003 . . . . .	FOP-8-6-9	HZV5-91352-000 . . . . .	F-10-61	HZW1-90520-800 . . . . .	F-4	HZW5-24826-U01 . . . . .	FOP-8-2-16
HZV5-24820-010 . . . . .	FOP-8-6-10	HZV5-91553-010 . . . . .	E-13-8	HZW1-90521-800 . . . . .	F-4	HZW5-24831-U01 . . . . .	FOP-8-16
HZV5-24830-010 . . . . .	FOP-8-6-11	HZV5-91553-010 . . . . .	E-15-22	HZW1-90559-000 . . . . .	F-3-20-16	HZW5-24831-U01 . . . . .	FOP-8-2-17
HZV5-24836-000 . . . . .	FOP-8-6-12	HZV5-91553-010 . . . . .	E-20-10-6	HZW1-90651-710 . . . . .	F-3-20-17	HZW5-24831-U01 . . . . .	FOP-8-4-12
HZV5-24841-000 . . . . .	FOP-8-6-13	HZV5-91553-010 . . . . .	F-7-10-18	HZW1-90652-702 . . . . .	F-11-32	HZW5-24832-U01 . . . . .	FOP-8-17
HZV5-24845-000 . . . . .	FOP-8-6-14	HZV5-91560-000 . . . . .	F-10-62	HZW1-90752-B02 . . . . .	F-4-24	HZW5-24832-U01 . . . . .	FOP-8-2-18
HZV5-24850-000 . . . . .	FOP-8-6-15	HZV5-91567-000 . . . . .	FOP-8-6-66	HZW1-90752-B02 . . . . .	FOP-10-4	HZW5-24832-U01 . . . . .	FOP-8-4-13
HZV5-24854-000 . . . . .	FOP-8-6-16	HZV5-91570-000 . . . . .	FOP-8-6-67	HZW1-90752-B02 . . . . .	FOP-10-1-9	HZW5-24834-U01 . . . . .	FOP-8-18
HZV5-24855-000 . . . . .	FOP-8-6-17	HZV7-90508-000 . . . . .	F-2-35	HZW1-90758-B00 . . . . .	F-5-19	HZW5-24834-U21 . . . . .	FOP-8-2-19
HZV5-24860-000 . . . . .	FOP-8-6-18	HZV7-90951-010 . . . . .	F-10-59	HZW1-90758-B00 . . . . .	F-5-1-21	HZW5-31217-003 . . . . .	E-21-5
HZV5-24865-000 . . . . .	FOP-8-6-19	HZW1-06411-020 . . . . .	F-10-1	HZW1-91054-B31 . . . . .	F-4-27	HZW5-31631-003 . . . . .	E-19-16
HZV5-24875-000 . . . . .	FOP-8-6-20	HZW1-12217-010 . . . . .	E-5-1	HZW1-91101-003 . . . . .	F-5-25	HZW5-31639-003 . . . . .	E-19-19
HZV5-24876-000 . . . . .	FOP-8-6-21	HZW1-15665-020 . . . . .	E-6-6	HZW1-91101-003 . . . . .	F-5-1-27	HZW5-31644-003 . . . . .	E-19-20
HZV5-24878-000 . . . . .	FOP-8-6-22	HZW1-19210-B04 . . . . .	F-4-2	HZW1-91207-013 . . . . .	F-11-34	HZW5-31710-003 . . . . .	E-19-21
HZV5-24881-000 . . . . .	FOP-8-6-23	HZW1-19210-B04 . . . . .	FOP-10-2	HZW1-91252-702 . . . . .	F-11-37	HZW5-32168-003 . . . . .	E-18-10-44
HZV5-24883-000 . . . . .	FOP-8-6-24	HZW1-19210-B04 . . . . .	FOP-10-1-2	HZW1-91353-703 . . . . .	F-11-38	HZW5-35370-U02 . . . . .	FOP-8-20
HZV5-24884-000 . . . . .	FOP-8-6-25	HZW1-19223-B00 . . . . .	F-4-4	HZW1-91354-701 . . . . .	F-11-39	HZW5-35370-U02 . . . . .	FOP-8-2-22
HZV5-24885-000 . . . . .	FOP-8-6-26	HZW1-19223-B00 . . . . .	FOP-10-1-4	HZW1-91355-701 . . . . .	F-11-40	HZW5-35370-U12 . . . . .	FOP-8-2-23
HZV5-24887-000 . . . . .	FOP-8-6-27	HZW1-19252-000 . . . . .	E-6-12	HZW1-91356-B00 . . . . .	F-4-32	HZW5-35673-003 . . . . .	E-9-10-11
HZV5-24891-000 . . . . .	FOP-8-6-28	HZW1-19253-B01 . . . . .	F-4-8	HZW1-91356-B00 . . . . .	FOP-10-5	HZW5-50151-000 . . . . .	F-10-12
HZV5-24892-000 . . . . .	FOP-8-6-29	HZW1-19253-B01 . . . . .	FOP-10-1-7	HZW1-91356-B00 . . . . .	FOP-10-1-10	HZW5-50155-000 . . . . .	F-3-20-6
HZV5-24894-000 . . . . .	FOP-8-6-30	HZW1-19286-B00 . . . . .	F-3-1	HZW1-91357-701 . . . . .	F-11-41	HZW5-50341-010 . . . . .	F-10-21
HZV5-24895-000 . . . . .	FOP-8-6-31	HZW1-24102-B00 . . . . .	F-5-2	HZW1-91358-701 . . . . .	F-11-42	HZW5-90002-013 . . . . .	E-5-14
HZV5-24897-000 . . . . .	FOP-8-6-32	HZW1-24102-B00 . . . . .	F-5-1-2	HZW1-91361-701 . . . . .	F-11-43	HZW5-90011-010 . . . . .	E-19-23
HZV5-24898-000 . . . . .	FOP-8-6-33	HZW1-24103-B00 . . . . .	F-5-3	HZW1-91554-000 . . . . .	E-14-39	HZW5-90018-000 . . . . .	E-5-18
HZV5-32823-003 . . . . .	FOP-6-10	HZW1-24103-B00 . . . . .	F-5-1-3	HZW1-91554-000 . . . . .	E-18-28	HZW5-90018-000 . . . . .	E-9-20-21

HZW5-90018-000 . . . . . E-20-10-5  
 HZW5-90018-000 . . . . . F-7-20-8  
 HZW5-90021-U00 . . . . . FOP-9-2  
 HZW5-90101-U00 . . . . . FOP-8-22  
 HZW5-90101-U00 . . . . . FOP-8-2-25  
 HZW5-90101-U00 . . . . . FOP-8-4-20  
 HZW5-90102-U00 . . . . . FOP-8-23  
 HZW5-90102-U00 . . . . . FOP-8-2-26  
 HZW5-90103-U01 . . . . . FOP-8-24  
 HZW5-90103-U01 . . . . . FOP-8-2-27  
 HZW5-90104-U00 . . . . . FOP-8-25  
 HZW5-90104-U00 . . . . . FOP-8-2-28  
 HZW5-90105-U01 . . . . . FOP-8-26  
 HZW5-90105-U01 . . . . . FOP-8-2-29  
 HZW5-90106-U00 . . . . . FOP-8-27  
 HZW5-90106-U00 . . . . . FOP-8-2-30  
 HZW5-90107-U00 . . . . . FOP-8-28  
 HZW5-90107-U00 . . . . . FOP-8-2-31  
 HZW5-90108-U00 . . . . . FOP-8-2-32  
 HZW5-90109-000 . . . . . FOP-6-22  
 HZW5-90109-000 . . . . . FOP-6-1-15  
 HZW5-90203-010 . . . . . E-19-29  
 HZW5-90301-U00 . . . . . FOP-8-29  
 HZW5-90301-U00 . . . . . FOP-8-2-33  
 HZW5-90302-003 . . . . . F-3-20-14  
 HZW5-90302-003 . . . . . F-10-40  
 HZW5-90302-U21 . . . . . FOP-8-2-34  
 HZW5-90303-000 . . . . . F-4-21  
 HZW5-90304-000 . . . . . F-10-43  
 HZW5-90501-U00 . . . . . FOP-8-30  
 HZW5-90501-U00 . . . . . FOP-8-2-35  
 HZW5-90501-U00 . . . . . FOP-8-4-26  
 HZW5-90502-U00 . . . . . FOP-8-32  
 HZW5-90502-U00 . . . . . FOP-8-2-37  
 HZW5-90503-U00 . . . . . FOP-8-33  
 HZW5-90503-U00 . . . . . FOP-8-2-38  
 HZW5-90509-711 . . . . . F-5-15  
 HZW5-90509-711 . . . . . F-5-1-16  
 HZW5-90511-U00 . . . . . FOP-9-3  
 HZW5-90512-U00 . . . . . FOP-9-4  
 HZW5-90548-710 . . . . . F-5-1-19  
 HZW5-90549-710 . . . . . F-5-1-  
 HZW5-90550-710 . . . . . F-5-1-  
 HZW5-90551-710 . . . . . F-5-1-  
 HZW5-90601-030 . . . . . E-18-22  
 HZW5-91056-003 . . . . . F-5-24  
 HZW5-91056-003 . . . . . F-5-1-26  
 HZW5-91201-003 . . . . . E-5-20  
 HZW5-91202-003 . . . . . E-6-43  
 HZW5-91251-003 . . . . . F-2-43  
 HZW7-24810-U01 . . . . . FOP-8-4-2  
 HZW7-24811-U01 . . . . . FOP-8-4-3  
 HZW7-24812-U01 . . . . . FOP-8-4-4  
 HZW7-24813-U01 . . . . . FOP-8-4-5  
 HZW7-24814-U01 . . . . . FOP-8-4-6  
 HZW7-24815-U01 . . . . . FOP-8-4-7  
 HZW7-24817-U01 . . . . . FOP-8-4-9  
 HZW7-24832-U01 . . . . . FOP-8-4-14  
 HZW7-24833-U01 . . . . . FOP-8-4-15  
 HZW7-32530-U00 . . . . . FOP-8-19  
 HZW7-32530-U00 . . . . . FOP-8-2-20  
 HZW7-32530-U10 . . . . . FOP-8-2-21  
 HZW7-32530-U20 . . . . . FOP-8-4-16  
 HZW7-35370-U02 . . . . . FOP-8-4-17  
 HZW7-87703-U00 . . . . . FOP-8-4-19  
 HZW7-90101-U01 . . . . . FOP-8-4-21  
 HZW7-90102-U01 . . . . . FOP-8-4-22  
 HZW7-90103-U01 . . . . . FOP-8-4-23  
 HZW7-90104-U01 . . . . . FOP-8-4-24  
 HZW7-90301-U01 . . . . . FOP-8-4-25  
 HZW7-90502-U00 . . . . . FOP-8-4-27  
 HZW9-19279-000 . . . . . E-6-16  
 HZW9-19291-000 . . . . . E-6-18  
 HZW9-19297-000 . . . . . E-6-20  
 HZW9-19317-000 . . . . . E-6-21  
 HZW9-32114-730 . . . . . E-3-13  
 HZW9-87702-800 . . . . . FOP-8-6-48  
 HZW9-90008-000 . . . . . FOP-8-6-49  
 HZW9-90009-000 . . . . . F-10-30  
 HZW9-90011-000 . . . . . E-3-21  
 HZW9-90011-000 . . . . . E-9-10-14  
 HZW9-90011-000 . . . . . F-7-10-9  
 HZW9-90013-000 . . . . . F-7-4  
 HZW9-90013-000 . . . . . F-7-10-10  
 HZW9-90013-000 . . . . . F-7-20-7  
 HZW9-90016-000 . . . . . E-3-22  
 HZW9-90016-000 . . . . . E-5-17  
 HZW9-90016-000 . . . . . E-6-27  
 HZW9-90016-000 . . . . . E-18-21  
 HZW9-90016-000 . . . . . E-18-10-47  
 HZW9-90101-003 . . . . . F-3-12  
 HZW9-90102-000 . . . . . E-6-36  
 HZW9-90102-000 . . . . . F-2-30  
 HZW9-90103-010 . . . . . F-3-20-10  
 HZW9-90105-000 . . . . . E-6-28  
 HZW9-90105-000 . . . . . F-2-31  
 HZW9-90105-000 . . . . . F-4-18  
 HZW9-90105-000 . . . . . F-10-34  
 HZW9-90506-000 . . . . . F-8-10-27  
 HZX1-63100-R00ZA . . . . . F-8-1  
 HZX1-87132-R00 . . . . . F-12-14  
 HZX1-87133-R00 . . . . . F-12-15  
 HZX1-90101-R00 . . . . . F-8-7  
 HZX1-90133-R00 . . . . . F-8-9  
 HZX2-41102-E00ZC . . . . . F-3-5  
 HZX2-41107-C00ZC . . . . . F-3-8  
 HZX2-90129-000 . . . . . F-10-39  
 HZY1-90205-000 . . . . . F-3-16  
 HZY1-90650-003 . . . . . FOP-11-5  
 HZY3-16011-000 . . . . . E-18-10-1  
 HZY3-16013-000 . . . . . E-18-10-2  
 HZY3-16024-000 . . . . . E-18-10-7  
 HZY3-16026-000 . . . . . E-18-10-8  
 HZY3-16041-000 . . . . . E-18-10-8  
 HZY3-16042-000 . . . . . E-18-10-11  
 HZY3-16061-000 . . . . . E-18-10-12  
 HZY3-16072-000 . . . . . E-18-10-13  
 HZY3-16073-000 . . . . . E-18-10-14  
 HZY3-16074-000 . . . . . E-18-10-15  
 HZY3-16075-000 . . . . . E-18-10-15  
 HZY3-16076-000 . . . . . E-18-10-17  
 HZY3-16077-000 . . . . . E-18-10-18  
 HZY3-16078-000 . . . . . E-18-10-19  
 HZY3-16082-000 . . . . . E-18-10-21  
 HZY3-16083-000 . . . . . E-18-10-22  
 HZY3-16087-000 . . . . . E-18-10-25  
 HZY3-16088-000 . . . . . E-18-10-26  
 HZY3-16721-000 . . . . . E-18-10-31  
 HZY3-16733-000 . . . . . E-18-10-35  
 HZY3-16752-000 . . . . . E-14-8  
 HZY3-16752-000 . . . . . E-18-10-39  
 HZY3-16807-003 . . . . . E-18-1-4  
 HZY3-16900-003 . . . . . E-18-1-5  
 HZY3-16901-003 . . . . . E-18-1-6  
 HZY3-16904-003 . . . . . E-18-1-7  
 HZY3-16911-010 . . . . . E-18-10-41  
 HZY3-16912-003 . . . . . E-18-1-8  
 HZY3-16913-000 . . . . . E-18-10-42  
 HZY3-16915-010 . . . . . E-18-1-10  
 HZY3-16918-003 . . . . . E-18-1-11  
 HZY3-16919-003 . . . . . E-18-1-12  
 HZY3-17738-000 . . . . . F-9-8  
 HZY3-19270-000 . . . . . F-9-9  
 HZY3-19271-000 . . . . . F-9-10  
 HZY3-19272-000 . . . . . F-9-11  
 HZY3-19300-023 . . . . . E-9-10-3  
 HZY3-23173-010 . . . . . E-6-24  
 HZY3-24318-000 . . . . . F-4-10  
 HZY3-24618-000 . . . . . F-2-15  
 HZY3-24619-000 . . . . . F-2-17  
 HZY3-30280-003 . . . . . F-11-1  
 HZY3-31106-003 . . . . . F-11-2  
 HZY3-31116-000 . . . . . E-5-13  
 HZY3-31207-003 . . . . . E-21-2  
 HZY3-31246-003 . . . . . E-21-14  
 HZY3-32128-000 . . . . . E-15-10  
 HZY3-32411-003 . . . . . F-7-10-3  
 HZY3-35470-023 . . . . . F-2-22  
 HZY3-35645-000 . . . . . F-8-20-3  
 HZY3-35673-003 . . . . . E-3-15  
 HZY3-35673-003 . . . . . E-4-7  
 HZY3-35673-003 . . . . . E-9-10-12  
 HZY3-36122-013 . . . . . F-11-4  
 HZY3-36123-013 . . . . . F-11-5  
 HZY3-36163-003 . . . . . E-14-16  
 HZY3-40119-003 . . . . . F-8-10-4  
 HZY3-40219-013 . . . . . F-11-8  
 HZY3-50381-000 . . . . . F-7-10-22  
 HZY3-50388-U00 . . . . . FOP-7-1  
 HZY3-50388-U10 . . . . . FOP-7-2  
 HZY3-56170-013 . . . . . F-11-21  
 HZY3-58130-T00 . . . . . F-5-11  
 HZY3-58130-T10 . . . . . F-5-  
 HZY3-58130-T20 . . . . . F-5-  
 HZY3-58130-T30 . . . . . F-5-  
 HZY3-58130-T40 . . . . . F-5-  
 HZY3-58130-T50 . . . . . F-5-  
 HZY3-58130-V01ZA . . . . . F-5-  
 HZY3-58130-V11ZA . . . . . F-5-  
 HZY3-58130-V21ZA . . . . . F-5-  
 HZY3-58130-V31ZA . . . . . F-5-  
 HZY3-58130-V41ZA . . . . . F-5-  
 HZY3-58130-V51ZA . . . . . F-5-  
 HZY3-58180-T00 . . . . . F-5-1-12  
 HZY3-58180-T10 . . . . . F-5-1-  
 HZY3-58180-T20 . . . . . F-5-1-  
 HZY3-58180-T30 . . . . . F-5-1-  
 HZY3-58180-T40 . . . . . F-5-1-  
 HZY3-63107-000 . . . . . F-8-3  
 HZY3-63108-000 . . . . . F-8-4  
 HZY3-63119-000 . . . . . F-8-5  
 HZY3-63201-000ZC . . . . . F-8-10-10  
 HZY3-63205-000 . . . . . F-2-25  
 HZY3-63205-000 . . . . . F-8-10-11  
 HZY3-63208-000 . . . . . F-8-10-13  
 HZY3-63212-000 . . . . . F-8-10-14  
 HZY3-63224-000 . . . . . F-8-10-17  
 HZY3-63260-000 . . . . . F-8-10-20  
 HZY3-90016-000 . . . . . E-9-10-15  
 HZY3-90017-000 . . . . . E-9-10-16  
 HZY3-90017-000 . . . . . E-9-20-20  
 HZY3-90017-000 . . . . . E-18-10-48  
 HZY3-90017-000 . . . . . E-19-24  
 HZY3-90017-000 . . . . . F-2-27  
 HZY3-90021-000 . . . . . E-4-9  
 HZY3-90021-000 . . . . . E-9-10-17  
 HZY3-90021-000 . . . . . E-9-20-22  
 HZY3-90021-000 . . . . . E-14-24  
 HZY3-90021-000 . . . . . E-18-1-13  
 HZY3-90021-000 . . . . . F-2-28  
 HZY3-90026-000 . . . . . E-3-23  
 HZY3-90026-000 . . . . . E-19-25  
 HZY3-90028-000 . . . . . F-2-29  
 HZY3-90030-000 . . . . . E-4-10  
 HZY3-90030-000 . . . . . E-6-32  
 HZY3-90030-000 . . . . . F-7-10-11  
 HZY3-90030-000 . . . . . F-8-10-23  
 HZY3-90035-000 . . . . . E-19-26  
 HZY3-90040-000 . . . . . E-9-10-19  
 HZY3-90042-000 . . . . . E-14-25  
 HZY3-90046-000 . . . . . E-6-34  
 HZY3-90049-000 . . . . . E-18-10-49  
 HZY3-90054-000 . . . . . E-3-24  
 HZY3-90054-000 . . . . . E-14-29  
 HZY3-90055-000 . . . . . E-19-27  
 HZY3-90056-000 . . . . . E-6-35  
 HZY3-90056-000 . . . . . E-15-19  
 HZY3-90084-000 . . . . . E-1-5  
 HZY3-90084-000 . . . . . E-20-3  
 HZY3-90107-000 . . . . . F-7-10-12  
 HZY3-90109-010 . . . . . F-8-8  
 HZY3-90111-000 . . . . . F-8-20-14  
 HZY3-90120-000 . . . . . F-3-14  
 HZY3-90204-000 . . . . . E-3-28  
 HZY3-90205-000 . . . . . E-14-32  
 HZY3-90304-000 . . . . . F-7-5  
 HZY3-90405-000 . . . . . F-7-10-14  
 HZY3-90506-000 . . . . . F-5-14  
 HZY3-90506-000 . . . . . F-5-1-15  
 HZY3-90507-000 . . . . . F-2-34  
 HZY3-90507-000 . . . . . F-8-11  
 HZY3-90512-000 . . . . . F-5-16  
 HZY3-90512-000 . . . . . F-5-1-17  
 HZY3-90528-000 . . . . . F-5-17  
 HZY3-90528-000 . . . . . F-5-1-18  
 HZY3-90529-000 . . . . . F-5-  
 HZY3-90529-000 . . . . . F-5-1-  
 HZY3-90530-000 . . . . . F-5-  
 HZY3-90530-000 . . . . . F-5-1-  
 HZY3-90531-000 . . . . . F-5-  
 HZY3-90531-000 . . . . . F-5-1-  
 HZY3-90601-030 . . . . . E-4-10-8  
 HZY3-90601-030 . . . . . E-6-40  
 HZY3-90602-020 . . . . . E-4-10-9  
 HZY3-90653-003 . . . . . F-7-6  
 HZY3-90751-000 . . . . . F-2-38  
 HZY3-91001-003 . . . . . E-6-42  
 HZY3-91152-003 . . . . . F-2-42  
 HZY3-91254-003 . . . . . F-4-30  
 HZY3-91255-003 . . . . . F-2-44  
 HZY3-91303-000 . . . . . E-21-22  
 HZY3-91351-003 . . . . . F-5-27  
 HZY3-91351-003 . . . . . F-5-1-29  
 HZY3-91556-000 . . . . . F-8-12  
 HZY6-06122-010ZA . . . . . E-9-20-1  
 HZY6-06192-000 . . . . . FOP-10-1  
 HZY6-06193-A01 . . . . . FOP-10-1-1  
 HZY6-06411-000 . . . . . F-10-2  
 HZY6-06532-U00 . . . . . F-10-3  
 HZY6-11100-405 . . . . . E-3-1  
 HZY6-11321-010ZB . . . . . E-6-1  
 HZY6-11381-010 . . . . . E-6-2  
 HZY6-11410-425ZA . . . . . E-9-10-1  
 HZY6-11412-000 . . . . . E-9-10-2  
 HZY6-11911-000 . . . . . E-3-5  
 HZY6-11912-000 . . . . . E-19-1  
 HZY6-12000-415ZA . . . . . E-3-6  
 HZY6-12251-003 . . . . . E-9-20-6  
 HZY6-12310-010ZA . . . . . E-1-1  
 HZY6-12500-000 . . . . . E-1-4  
 HZY6-13010-000 . . . . . E-7-1  
 HZY6-13101-000 . . . . . E-7-2  
 HZY6-13102-000 . . . . . E-7-7  
 HZY6-13211-004 . . . . . E-7-7  
 HZY6-13212-004 . . . . . E-7-  
 HZY6-13213-004 . . . . . E-7-  
 HZY6-13214-004 . . . . . E-7-  
 HZY6-13215-004 . . . . . E-7-  
 HZY6-13216-004 . . . . . E-7-  
 HZY6-13217-004 . . . . . E-7-  
 HZY6-13331-013 . . . . . E-7-10  
 HZY6-13400-000 . . . . . E-10-1  
 HZY6-13811-000 . . . . . E-7-14  
 HZY6-14110-000 . . . . . E-9-2  
 HZY6-14120-000 . . . . . E-9-5  
 HZY6-14311-000 . . . . . E-9-7  
 HZY6-14510-003 . . . . . E-9-9  
 HZY6-14751-003 . . . . . E-9-24  
 HZY6-15100-000ZA . . . . . E-5-2  
 HZY6-15112-000 . . . . . E-5-3  
 HZY6-15121-000 . . . . . E-5-4  
 HZY6-15152-000 . . . . . E-3-7  
 HZY6-15220-010 . . . . . E-6-4  
 HZY6-15299-000 . . . . . E-3-10  
 HZY6-15410-010ZA . . . . . E-5-11  
 HZY6-15425-010 . . . . . E-4-10-1  
 HZY6-15655-000 . . . . . E-6-5  
 HZY6-15810-013ZA . . . . . E-9-20-8  
 HZY6-15834-000 . . . . . E-9-20-11  
 HZY6-15840-000ZA . . . . . E-9-20-12  
 HZY6-16014-003 . . . . . E-18-10-3  
 HZY6-16016-003 . . . . . E-15-1  
 HZY6-16017-043 . . . . . E-18-10-4  
 HZY6-16019-003 . . . . . E-18-10-5  
 HZY6-16020-023 . . . . . E-18-10-6  
 HZY6-16036-003 . . . . . E-18-10-9  
 HZY6-16089-000 . . . . . E-14-1  
 HZY6-16196-000 . . . . . E-18-2  
 HZY6-16198-000 . . . . . E-18-3  
 HZY6-16199-000 . . . . . E-18-4  
 HZY6-16400-013 . . . . . E-15-2  
 HZY6-16450-003 . . . . . E-14-2  
 HZY6-16451-000 . . . . . E-14-3  
 HZY6-16621-000 . . . . . E-14-4  
 HZY6-16700-013 . . . . . E-18-5  
 HZY6-16701-003 . . . . . E-18-10-27  
 HZY6-16718-013 . . . . . E-18-10-30  
 HZY6-16723-003 . . . . . E-18-10-32  
 HZY6-16730-063 . . . . . E-18-10-33  
 HZY6-16734-003 . . . . . E-18-10-36  
 HZY6-16736-003 . . . . . E-18-10-38  
 HZY6-16740-003 . . . . . E-14-5



HZY6-16744-010. . . . .	E-14-6	HZY6-24614-000. . . . .	F-2-14	HZY6-41151-000. . . . .	F-5-8	HZY6-91055-004. . . . .	F-5-23
HZY6-16748-000. . . . .	E-14-7	HZY6-24618-000. . . . .	F-2-16	HZY6-41161-000. . . . .	F-5-9	HZY6-91055-004. . . . .	F-5-1-25
HZY6-16752-000. . . . .	E-14-9	HZY6-24620-000. . . . .	F-2-18	HZY6-41161-710. . . . .	F-5-1-9	HZY6-91251-003. . . . .	F-4-28
HZY6-16755-003. . . . .	E-18-6	HZY6-24628-000. . . . .	F-2-19	HZY6-41173-000. . . . .	F-10-10	HZY6-91301-003. . . . .	E-4-13
HZY6-16800-003. . . . .	E-18-1-2	HZY6-24629-000ZA. . . . .	F-2-20	HZY6-41201-000ZC. . . . .	F-5-10	HZY6-91302-003. . . . .	E-4-14
HZY6-16805-003. . . . .	E-18-1-3	HZY6-30410-000. . . . .	E-20-10-1	HZY6-41201-710ZC. . . . .	F-5-1-10	HZY6-91303-003. . . . .	E-9-20-24
HZY6-16840-A00. . . . .	E-18-10-40	HZY6-30530-003. . . . .	E-3-12	HZY6-41202-710. . . . .	F-5-1-11	HZY6-91304-010. . . . .	E-9-10-24
HZY6-16850-A01. . . . .	F-9-1	HZY6-31110-000ZA. . . . .	E-5-12	HZY6-50100-000. . . . .	F-10-11	HZY6-91305-003. . . . .	E-3-35
HZY6-16860-A00. . . . .	F-9-2	HZY6-31200-003. . . . .	E-21-1	HZY6-50167-000. . . . .	F-10-13	HZY6-91351-003. . . . .	F-4-31
HZY6-16871-A00. . . . .	F-9-3	HZY6-31216-003. . . . .	E-21-4	HZY6-50168-003. . . . .	F-10-14	HZY6-91502-003. . . . .	E-9-35
HZY6-16881-A00. . . . .	F-9-4	HZY6-31226-003. . . . .	E-21-7	HZY6-50209-000. . . . .	F-10-16	HZY6-91552-000. . . . .	F-4-34
HZY6-16890-A00. . . . .	F-9-5	HZY6-31227-003. . . . .	E-21-	HZY6-56000-043. . . . .	F-11-10	HZY6-91552-000. . . . .	FOP-10-1-11
HZY6-16914-010. . . . .	E-18-1-9	HZY6-31231-003. . . . .	E-21-9	HZY6-56100-013. . . . .	F-11-11	HZY6-91553-000. . . . .	F-8-20-19
HZY6-17051-000ZA. . . . .	E-14-10	HZY6-31232-003. . . . .	E-21-	HZY6-56118-000. . . . .	F-10-27	HZY9-17315-000. . . . .	E-15-4
HZY6-17105-000. . . . .	E-14-12	HZY6-31235-003. . . . .	E-21-10	HZY6-60180-003. . . . .	F-8-10-8	HZY9-30419-003. . . . .	E-20-10-2
HZY6-17109-000. . . . .	E-14-13	HZY6-31236-003. . . . .	E-21-11	HZY6-60185-003. . . . .	F-8-10-9	HZY9-31207-H01. . . . .	E-21-
HZY6-17110-003. . . . .	E-14-14	HZY6-31240-003. . . . .	E-21-12	HZY6-63102-010. . . . .	F-8-2	HZY9-31226-H01. . . . .	E-21-
HZY6-17371-020. . . . .	E-15-5	HZY6-31242-003. . . . .	E-21-13	HZY6-63144-000. . . . .	F-8-6	HZY9-31229-H01. . . . .	E-21-
HZY6-17374-000. . . . .	E-15-6	HZY6-31630-003. . . . .	E-19-15	HZY6-63205-000. . . . .	F-8-10-12	HZY9-31240-003. . . . .	E-21-
HZY6-17397-013. . . . .	E-15-7	HZY6-31636-010. . . . .	E-19-17	HZY6-63212-000. . . . .	F-8-10-15	HZY9-31242-H01. . . . .	E-21-
HZY6-17398-000. . . . .	E-15-8	HZY6-31637-000. . . . .	E-19-18	HZY6-63223-000. . . . .	F-8-10-16	HZY9-31246-H01. . . . .	E-21-
HZY6-17431-000. . . . .	E-13-1	HZY6-31638-003. . . . .	E-13-3	HZY6-63225-000. . . . .	F-8-10-18	HZY9-31251-H01. . . . .	E-21-23
HZY6-17432-000. . . . .	E-13-2	HZY6-31750-003. . . . .	E-19-22	HZY6-63240-000. . . . .	F-8-10-19	HZY9-56115-003. . . . .	F-11-15
HZY6-17723-020. . . . .	E-18-13	HZY6-32100-070. . . . .	F-7-1	HZY6-63711-010ZC. . . . .	F-8-20-9	HZY9-56120-003. . . . .	F-11-19
HZY6-17840-000. . . . .	F-2-2	HZY6-32101-000. . . . .	F-7-10-1	HZY6-63716-010ZC. . . . .	F-8-20-10	HZY9-90017-000. . . . .	E-15-18
HZY6-17845-000. . . . .	F-2-3	HZY6-32111-000. . . . .	E-14-15	HZY6-63718-000. . . . .	F-8-20-11	HZZ3-06240-R30. . . . .	FOP-8-1
HZY6-17860-000. . . . .	F-2-4	HZY6-32112-000. . . . .	E-9-10-9	HZY6-63719-000. . . . .	F-8-20-12	HZZ3-06240-R40. . . . .	FOP-8-4-1
HZY6-17877-010. . . . .	F-2-5	HZY6-32113-000. . . . .	E-9-10-10	HZY6-82873-000. . . . .	F-8-20-13	HZZ3-06240-R60. . . . .	FOP-8-2-1
HZY6-17931-000. . . . .	F-2-6	HZY6-32114-010. . . . .	E-3-14	HZY6-87117-640. . . . .	F-12-1	HZZ3-06323-R20. . . . .	FOP-6-1
HZY6-18110-415ZA. . . . .	E-4-2	HZY6-32115-000. . . . .	E-15-9	HZY6-87121-R00. . . . .	F-12-13	HZZ3-06323-R30. . . . .	FOP-6-1-1
HZY6-18112-030ZA. . . . .	E-4-3	HZY6-32116-000. . . . .	E-9-20-14	HZY6-87531-000. . . . .	F-12-10	HZZ3-06328-762. . . . .	FOP-11-1
HZY6-18115-003. . . . .	E-4-4	HZY6-32166-003. . . . .	E-18-10-43	HZY6-89216-000. . . . .	F-13-5	HZZ3-19277-000. . . . .	E-6-15
HZY6-18130-000ZA. . . . .	E-6-8	HZY6-32370-004. . . . .	F-7-20-1	HZY6-90001-000. . . . .	E-3-18	HZZ3-24800-R00. . . . .	FOP-8-6-1
HZY6-18135-003. . . . .	E-6-9	HZY6-32371-004. . . . .	F-7-20-2	HZY6-90001-000. . . . .	F-8-10-22	HZZ3-24820-R11. . . . .	FOP-8-13
HZY6-18211-000. . . . .	E-6-10	HZY6-32410-020. . . . .	F-7-10-2	HZY6-90002-000. . . . .	E-6-25	HZZ3-24820-R21. . . . .	FOP-8-2-14
HZY6-18212-000. . . . .	E-6-11	HZY6-32414-300. . . . .	F-7-3	HZY6-90002-000. . . . .	F-3-20-9	HZZ3-24830-R41. . . . .	FOP-8-4-11
HZY6-19221-A00. . . . .	F-4-3	HZY6-32414-300. . . . .	F-7-10-4	HZY6-90005-000. . . . .	E-3-19	HZZ3-32186-000. . . . .	FOP-11-2
HZY6-19221-A00. . . . .	FOP-10-1-3	HZY6-32414-640. . . . .	F-7-10-5	HZY6-90006-000. . . . .	E-15-16	HZZ3-32341-R31. . . . .	FOP-6-5
HZY6-19231-000. . . . .	F-4-5	HZY6-32418-000. . . . .	F-2-21	HZY6-90010-000. . . . .	E-18-19	HZZ3-32346-R21. . . . .	FOP-6-6
HZY6-19231-000. . . . .	FOP-10-1-5	HZY6-32419-000. . . . .	F-7-10-6	HZY6-90011-000. . . . .	E-9-20-19	HZZ3-32346-R31. . . . .	FOP-6-1-3
HZY6-19234-000. . . . .	F-4-6	HZY6-34750-053. . . . .	E-20-10-3	HZY6-90013-000. . . . .	E-4-8	HZZ3-32347-R01. . . . .	FOP-6-7
HZY6-19234-000. . . . .	FOP-10-3	HZY6-35475-000. . . . .	F-2-23	HZY6-90014-000. . . . .	E-6-26	HZZ3-35100-R11. . . . .	FOP-6-13
HZY6-19234-000. . . . .	FOP-10-1-6	HZY6-35640-003. . . . .	F-8-20-2	HZY6-90017-000. . . . .	E-6-29	HZZ3-35100-R11. . . . .	FOP-6-1-7
HZY6-19251-000. . . . .	F-4-7	HZY6-35660-013. . . . .	F-10-8	HZY6-90018-000. . . . .	E-6-30	HZZ3-35100-R11. . . . .	FOP-8-6-38
HZY6-19251-611. . . . .	F-4-	HZY6-35668-003. . . . .	E-4-6	HZY6-90019-000. . . . .	E-6-31	HZZ3-35340-741. . . . .	FOP-12-1
HZY6-19254-000. . . . .	E-6-13	HZY6-36104-003. . . . .	F-10-9	HZY6-90020-000. . . . .	E-10-10	HZZ3-35341-740. . . . .	FOP-12-2
HZY6-19256-000. . . . .	E-6-14	HZY6-36120-013. . . . .	F-11-3	HZY6-90023-000. . . . .	E-9-10-18	HZZ3-35342-740. . . . .	FOP-12-3
HZY6-19260-020. . . . .	E-4-10-3	HZY6-36129-013. . . . .	F-11-6	HZY6-90043-000. . . . .	E-14-26	HZZ3-35343-740. . . . .	FOP-12-4
HZY6-19261-010. . . . .	E-4-10-4	HZY6-36135-003. . . . .	E-18-17	HZY6-90045-000. . . . .	E-6-33	HZZ3-35344-740. . . . .	FOP-12-5
HZY6-19262-010. . . . .	E-4-10-5	HZY6-36364-000. . . . .	E-14-17	HZY6-90047-000. . . . .	E-14-27	HZZ3-35345-741. . . . .	FOP-12-6
HZY6-19263-000. . . . .	E-4-10-6	HZY6-36366-000. . . . .	E-14-18	HZY6-90048-010. . . . .	E-9-20-23	HZZ3-37205-R01. . . . .	FOP-6-17
HZY6-19266-000. . . . .	E-4-10-7	HZY6-36550-003. . . . .	E-14-20	HZY6-90049-000. . . . .	E-14-28	HZZ3-41117-000. . . . .	F-4-15
HZY6-19267-010. . . . .	E-18-14	HZY6-36551-003. . . . .	E-14-21	HZY6-90059-000. . . . .	E-9-10-20	HZZ3-87301-R00. . . . .	F-12-16
HZY6-19268-000. . . . .	E-4-5	HZY6-37521-000. . . . .	E-9-20-16	HZY6-90082-003. . . . .	E-3-25	HZZ3-87701-R00. . . . .	FOP-8-6-47
HZY6-19269-000. . . . .	E-18-15	HZY6-38228-003. . . . .	F-7-20-3	HZY6-90102-000. . . . .	F-10-32	HZZ3-87701-R40. . . . .	FOP-8-4-18
HZY6-19273-000. . . . .	E-18-16	HZY6-38235-004. . . . .	F-7-20-4	HZY6-90103-000. . . . .	F-3-13	HZZ3-87703-R01. . . . .	FOP-8-2-24
HZY6-19289-000. . . . .	F-8-20-1	HZY6-38550-003. . . . .	F-7-10-7	HZY6-90104-000. . . . .	F-5-12	HZZ3-87703-R81. . . . .	FOP-8-21
HZY6-19290-003. . . . .	E-6-17	HZY6-38552-000. . . . .	E-3-17	HZY6-90104-000. . . . .	F-5-1-13	HZZ3-91252-003. . . . .	F-5-26
HZY6-19295-000. . . . .	E-6-19	HZY6-39794-003. . . . .	F-7-20-6	HZY6-90105-000. . . . .	F-3-20-11	HZZ3-91252-003. . . . .	F-5-1-28
HZY6-19300-003. . . . .	E-9-10-4	HZY6-40105-020. . . . .	F-8-10-2	HZY6-90105-000. . . . .	F-8-10-24	HZZ3-91253-003. . . . .	F-4-29
HZY6-19313-000ZB. . . . .	E-9-10-5	HZY6-40114-010. . . . .	F-8-20-4	HZY6-90116-000. . . . .	F-4-19	HZZ5-06325-600. . . . .	FOP-6-2
HZY6-19315-010. . . . .	E-9-10-6	HZY6-40116-000. . . . .	F-8-20-5	HZY6-90116-000. . . . .	FOP-10-1-8	HZZ5-06325-700. . . . .	FOP-6-
HZY6-19318-010. . . . .	E-9-10-7	HZY6-40151-010ZD. . . . .	F-8-20-6	HZY6-90118-000. . . . .	F-3-20-12	HZZ5-06325-800. . . . .	FOP-6-
HZY6-19319-000. . . . .	E-9-10-8	HZY6-40152-300. . . . .	F-8-20-7	HZY6-90123-000. . . . .	F-3-15	HZZ5-32185-600. . . . .	FOP-6-4
HZY6-23170-000ZA. . . . .	E-6-22	HZY6-40154-000ZC. . . . .	F-8-10-5	HZY6-90135-004. . . . .	F-7-20-9	HZZ5-32185-700. . . . .	FOP-6-
HZY6-23172-000. . . . .	E-6-23	HZY6-40155-000. . . . .	F-8-10-6	HZY6-90201-000. . . . .	E-1-6	HZZ5-32185-800. . . . .	FOP-6-
HZY6-24101-000. . . . .	F-5-1	HZY6-40157-000. . . . .	F-8-10-7	HZY6-90301-000. . . . .	F-8-20-15	HZZ5-32530-000. . . . .	FOP-8-6-34
HZY6-24101-000. . . . .	F-5-1-1	HZY6-40201-000ZC. . . . .	F-3-20-2	HZY6-90401-000. . . . .	E-1-7	HZZ5-32545-000. . . . .	FOP-6-8
HZY6-24122-000. . . . .	F-5-4	HZY6-40201-611ZC. . . . .	F-3-20-	HZY6-90601-000. . . . .	E-18-23	HZZ5-32545-000. . . . .	FOP-6-1-4
HZY6-24122-000. . . . .	F-5-1-4	HZY6-40212-020ZC. . . . .	F-8-20-8	HZY6-90602-020. . . . .	E-4-10-10	HZZ5-32580-600. . . . .	FOP-6-9
HZY6-24123-000. . . . .	F-5-5	HZY6-40219-023. . . . .	F-3-20-4	HZY6-90603-003. . . . .	E-4-10-11	HZZ5-32580-700. . . . .	FOP-6-
HZY6-24123-000. . . . .	F-5-1-5	HZY6-41100-040ZC. . . . .	F-3-10-1	HZY6-90604-003. . . . .	E-4-12	HZZ5-32580-800. . . . .	FOP-6-
HZY6-24124-000. . . . .	F-5-6	HZY6-41100-614ZC. . . . .	F-3-10-	HZY6-90605-003. . . . .	E-18-25	HZZ5-37210-013. . . . .	FOP-8-6-44
HZY6-24124-000. . . . .	F-5-1-6	HZY6-41100-714ZC. . . . .	F-3-10-	HZY6-90606-003. . . . .	E-6-41	HZZ5-37210-712. . . . .	FOP-6-1-11
HZY6-24166-000. . . . .	F-2-8	HZY6-41101-020ZC. . . . .	F-3-3	HZY6-90607-000. . . . .	E-18-10-51	HZZ5-37210-762. . . . .	FOP-6-18
HZY6-24218-000. . . . .	F-2-9	HZY6-41104-010. . . . .	F-3-6	HZY6-90651-000. . . . .	F-9-13	HZZ5-38414-003. . . . .	FOP-6-21
HZY6-24310-000. . . . .	F-4-9	HZY6-41105-010. . . . .	F-3-7	HZY6-90701-000. . . . .	E-10-12	HZZ5-38414-003. . . . .	FOP-6-1-14
HZY6-24310-710. . . . .	F-4-	HZY6-41112-010. . . . .	F-4-13	HZY6-90752-000. . . . .	F-2-39	HZZ5-50211-000. . . . .	F-10-17
HZY6-24320-000. . . . .	F-2-10	HZY6-41112-611. . . . .	F-4-	HZY6-90753-000. . . . .	F-2-40		
HZY6-24320-610. . . . .	F-2-	HZY6-41131-000. . . . .	F-4-16	HZY6-90755-003. . . . .	F-2-41		
HZY6-24343-000. . . . .	F-4-11	HZY6-41140-000. . . . .	F-5-7	HZY6-91051-003. . . . .	F-5-22		
HZY6-24610-000. . . . .	F-2-12	HZY6-41141-710. . . . .	F-5-1-7	HZY6-91051-003. . . . .	F-5-1-24		
HZY6-24612-020. . . . .	F-2-13	HZY6-41150-710. . . . .	F-5-1-8	HZY6-91052-003. . . . .	F-4-26		

## Note



**TOHATSU CORPORATION**

**Address : 5-4,3-chome,Azusawa,Itabashi-ku,  
TOKYO,174-0051 JAPAN**

**Phone : TOKYO (03)3966-3117**

**FAX : TOKYO (03)3966-0090**

**Website : [www.tohatsu.co.jp](http://www.tohatsu.co.jp)**