

2016 PARTS CATALOG

 TOHATSU

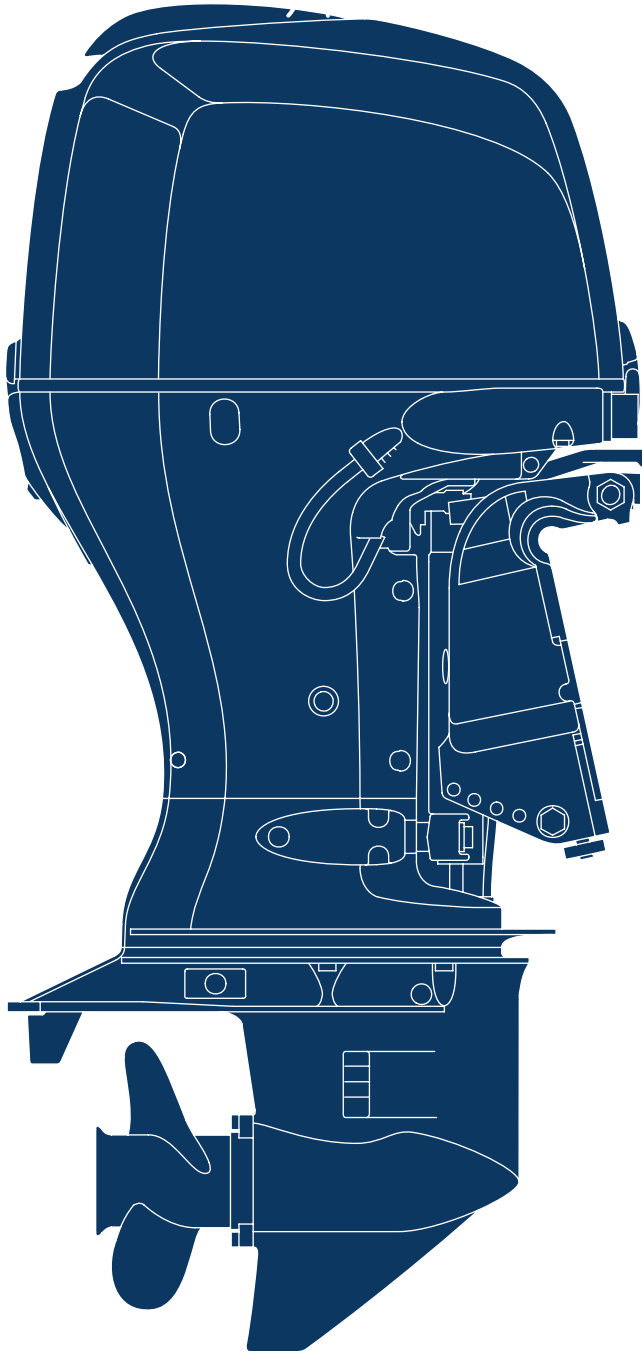

BFT 75A
BFT 90A

OB NO.002-14ZY9ET1-0AF
1510US

Instruction for use of parts catalogue

- **This parts catalogue was prepared based on the latest information available as of October 1, 2015.**
- See the Service Bulletin for any revision that is made after October 1, 2015.
- **Always specify the part number when ordering a part.**
 - Check the model, type, serial numbers, color, maker, and the size as needed before ordering a part.
 - Note that the illustrations (part drawings) can differ from the actual parts in shape.
Illustrations are given just to help you to refer to the parts.
- **When modifications or additions to this parts catalogue are made, a revised edition will be issued at an appropriate time, with successively progressing revision numbers on the cover. We recommend obtaining such revisions in order to keep your parts catalogue up-to-date at all times.**

Initial version issue date October 1, 2015

CONTENTS

E-1	CYLINDER HEAD COVER	1
E-2	CYLINDER HEAD	3
E-3	CYLINDER BLOCK	7
E-5	OIL PUMP	11
E-6	OIL CASE	13
E-7	CRANKSHAFT/PISTON/FLYWHEEL	15
E-9	CAMSHAFT/VALVE/BELT	19
E-9-10	CHAIN CASE/THERMOSTAT	23
E-14	INLET MANIFOLD/INJECTOR	25
E-15	SILENCER CASE/THROTTLE BODY	27
E-18	FUEL PUMP	29
E-18-10	WATER SEPARATOR	31
E-18-20	VAPOR SEPARATOR	33
E-19	A.C. GENERATOR	37
E-20	PLUG TOP COIL	39
E-20-10	ELECTRONIC CONTROL UNIT	41
E-21	STARTER MOTOR	43
F-2	SHIFT SHAFT	45
F-3	EXTENSION CASE	49
F-3-10	GEAR CASE	53
F-3-20	GEAR CASE ASSY.	57
F-3-30	MOUNT CASE	59
F-4	WATER PUMP/VERTICAL SHAFT	61
F-5	PROPELLER SHAFT	65
F-6	FUEL TUBE	69
F-7	MAIN WIRE HARNESS	71
F-7-10	STARTER CABLE	73
F-7-20	ELECTRONIC PARTS CASE	75
F-7-30	A.C. GENERATOR COVER	77
F-8	ENGINE COVER/UNDER COVER	79
F-10	STERN BRACKET/SWIVEL CASE	83
F-11	POWER TRIM-TILT	89
F-12	LABEL	93
F-13	TOOL	95
F-15	REMOTE CONTROL(1)	97
F-15-1	REMOTE CONTROL(2)	103
FOP-3	IMPELLER PUMP KIT	107
FOP-4	REMOTE CONTROL(TOP MOUNT SINGLE TYPE) (RIGHT)	109
FOP-4-2	REMOTE CONTROL(TOP MOUNT DUAL TYPE) (RIGHT)	113
FOP-4-4	REMOTE CONTROL(FLUSH MOUNT TYPE) (RIGHT)	117
FOP-6	SWITCH PANEL KIT(1)	119
FOP-6-1	SWITCH PANEL KIT(2)	123
FOP-7	METER	125
FOP-8	PROPELLER	127
FOP-9	BOLT KIT	129
FOP-10	STEERING HANDLE KIT	131
FOP-11	INTERFACE CABLE KIT	139
FOP-12	TROLLING CONTROL SWITCH	141
	INDEX	143
	INDEX (Parts Number)	149

Part catalogue structure

Ref.No.	Part No.	Description	Q. ty	REMARKS
E-2	H2V1=1211E=000	METAL ANGLE	2	2
E-2	HFU1=1220P=005	GUIDE IN VALVE(S)	8	8
E-2	HFU1=1220S=005	GUIDE EX VALVE(S)	8	8
E-2	HF21=1211S=004	SEAL A VALVE STEM(S)	8	8
E-2	H2V1=1211H=002A	HEAD COMP, CYLINDER	1	1 H#H DARK GRAY
E-2	HF21=12211=004	SEAL B VALVE STEM(S)	8	8
E-2	H2W1=1221F=010	BOLT SEALING 20MM	2	2
E-2	H2Y1=1221H=010	GASKET COMP, CYLINDER HEAD	1	1
E-2	HF2A=1410S=013	MOTION COMP, LOST	1	4
E-2	H2Z1=1310S=002A	VALVE ASSY, SPOOL	1	1 H#H DARK GRAY
E-2	HRM1=1311S=002	FILTER ASSY, SPOOL VALVE	1	1
E-2	H2Y1=1311F=000	COVER ASSY, OIL PATH	1	1
E-2	H2Y1=1311T=000	LIFTER FUEL PUMP	1	1
E-2	H2Y1=1311S=002	CLAMP B. FUEL TUBE	1	1
E-2	H2Y1=1300S=002	THERMOSTAT ASSY	1	1
E-2	H2W1=1311S=000	COVER THERMOSTAT	1	1
E-2	H2W1=1311T=000	O-RING THERMOSTAT COVER	1	1
E-2	H2Y1=1301S=010	COVER WATER JACKET	1	1
E-2	H2Y1=1301T=000	PACKING EX WATER JACKET	1	1 COVER
E-2	H2Y1=1311S=002	RECTIFIER ASSY, REGULATOR	1	1
E-2	H2Y1=1311S=000	PACKING REGULATOR	1	1
E-2	H2Y1=1311L=000	BRACKET B. HARNESS CLIP	1	1
E-2	H2Y1=1310S=001	SENSOR OXYGEN	1	1
E-2	H2Y1=1311T=002	SENSOR ASSY, WATER	1	1 TEMPERATURE
E-2	H2Y1=1301S=002	SENSOR ASSY, TDC	1	1
E-2	HPW1=1301P=002	BOLT WASHER 8X135	10	10
E-2	H2Y1=1301T=000	BOLT FLANGE 8X95	1	1
E-2	H2Y1=1301S=000	BOLT FLANGE 8X110	1	1
E-2	H2Y1=1301T=000	BOLT FLANGE 8X115	1	1

- ① Fig. Number
- ② Fig. Title
- ③ Ref. Number
- ④ Parts Number
- ⑤ Parts Name
- ⑥ Q.ty
- ⑦ Remarks
- ⑧ Defferent specification
- ⑨ Direction Arrow
- ⑩ Parts enclosed within a dotted line are sub assembly parts.
- ⑪ A solid arrow indicates the block No. the part in question is connected to.

How to check the part block and serial numbers

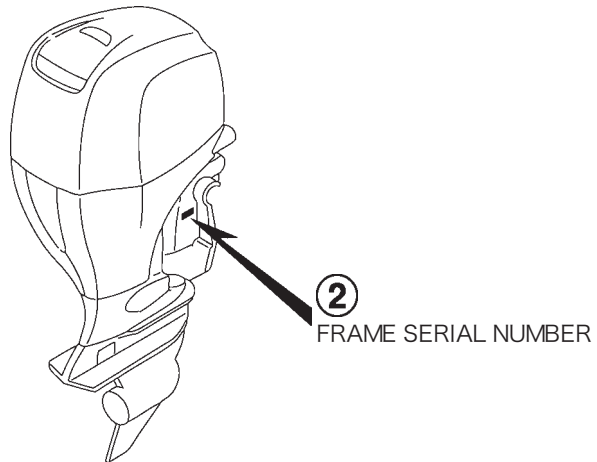
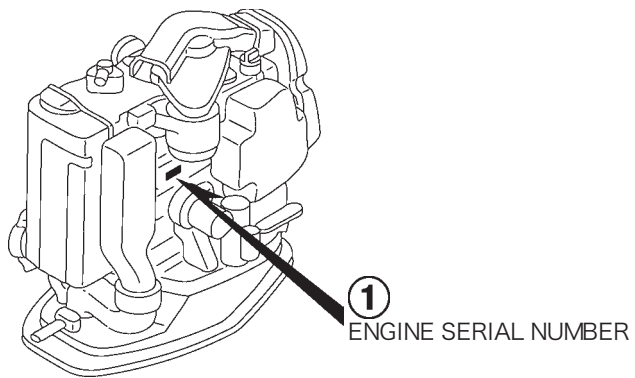
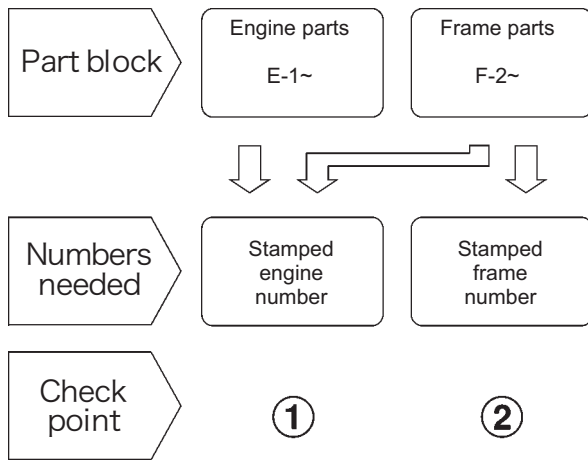

Models, parts catalogue codes and applicable serial numbers

- Models, parts catalogue codes and applicable serial Nos. given in this parts catalogue can be identified as follows.

Model	Type	Parts catalogue type	Engine		Applicable engine serial No.	Applicable frame serial No.
			Model	Type		
BFT 75A	LRTA	LRTA	BF 75DK3	SE	BEBAJ-1200001~	BBAJ-6000066~
BFT 90A	LRTA	LRTA	BF 90DK4		BEBCJ-1200001~	BBCJ-6000168~
	XRTA	XRTA				

Features of each type

- See the following table for the features of each type. (Items in brackets are optional)

Specifications		Model	BFT 75DK3	
		Type	LRTA	
Transom height	537 mm		●	
Remote control			(●)	
Fuel tank			(●)	

Specifications		Model	BFT 90DK4	
		Type	LRTA	XRTA
Transom height	537 mm		●	
	664 mm			●
Remote control			(●)	(●)
Fuel tank			(●)	(●)

Fuel hose, general purpose hoses and vinyl hose

- The standard part fuel hose, general purpose hose and vinyl hose may be substituted by the coiled bulk part.
- When ordering the standard part fuel hose, general purpose hose and vinyl hose use the bulk part number written in the parts catalog in brackets () underneath the part name.
- When exchanging the hose, cut and use at the specified length as mentioned in the part name. (For the method of cutting the bulk part, and method of filling out orders etc., please refer to the instructions issued with the bulk part.)

Bulk part number of fuel hose, general purpose hose and vinyl hose.

Example: 95001-75001-50M

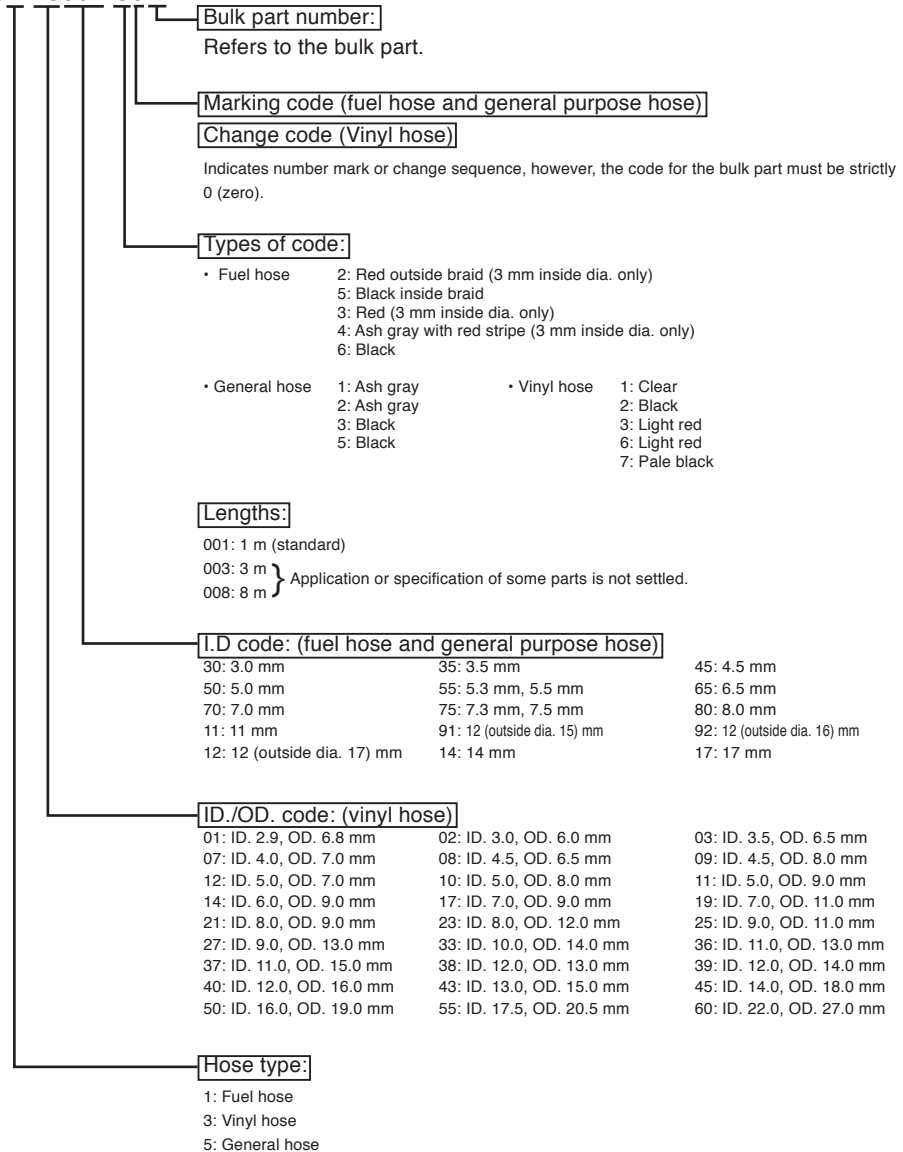

CAUTION: It is DANGEROUS to confuse the fuel hose with the general purpose hose or vinyl hose.

Never use a general purpose hose or vinyl hose in place of a fuel hose or vice versa.

Always use the correct bulk part in the parts catalogue, according to the service manual or the instructions issued with the bulk part.

E-1 CYLINDER HEAD COVER

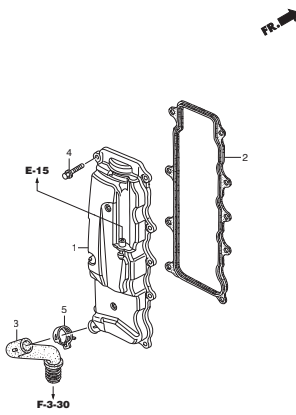

E-2 CYLINDER HEAD

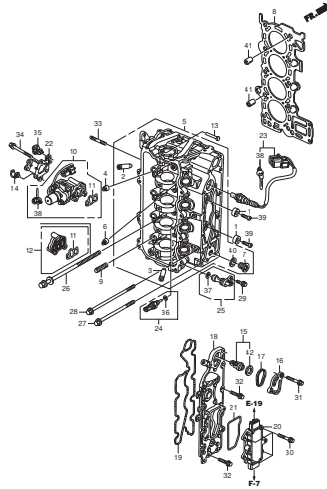

E-3 CYLINDER BLOCK

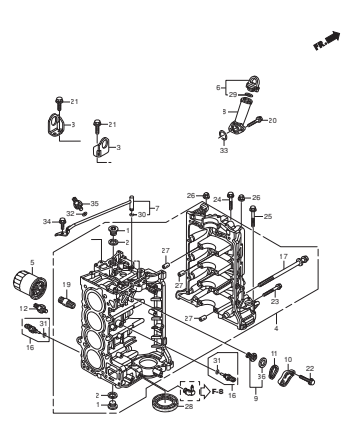

E-5 OIL PUMP

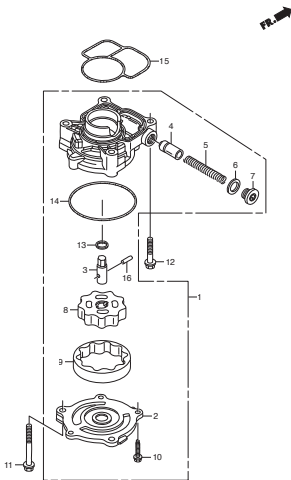

E-6 OIL CASE

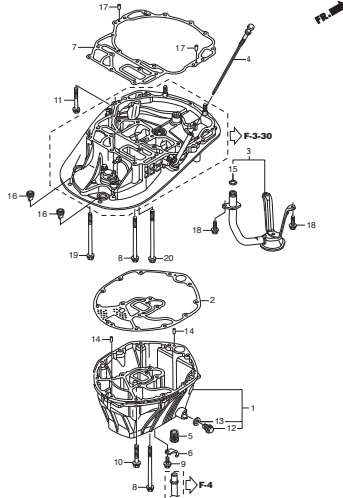

E-7 CRANKSHAFT/PISTON/FLYWHEEL

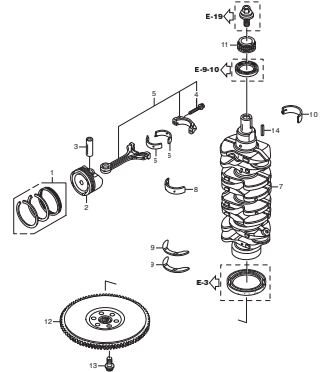

E-9 CAMSHAFT/VALVE/BELT

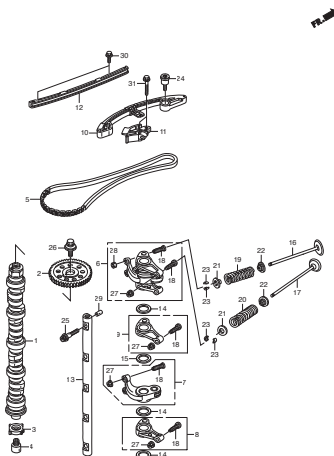

E-9-10 CHAIN CASE/THERMOSTAT

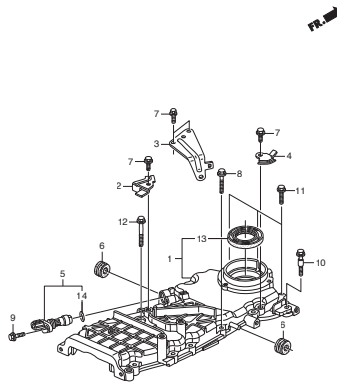

E-14 INLET MANIFOLD/INJECTOR

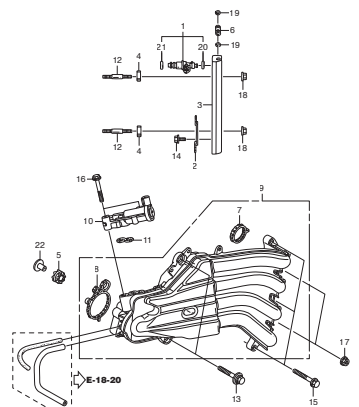

E-15 SILENCER CASE/THROTTLE BODY

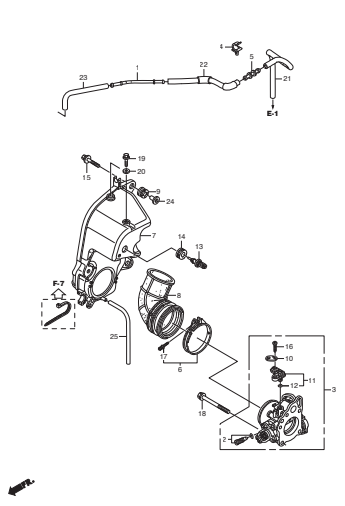

E-18 FUEL PUMP

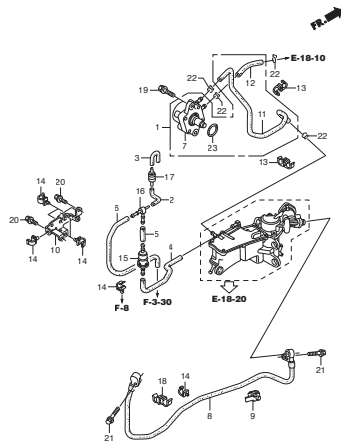

E-18-10 WATER SEPARATOR

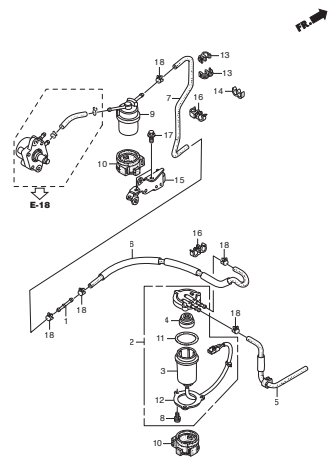

E-18-20 VAPOR SEPARATOR

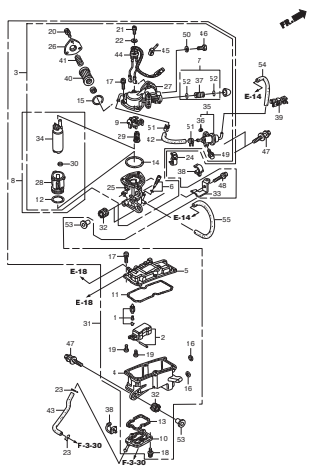

E-19 A.C. GENERATOR

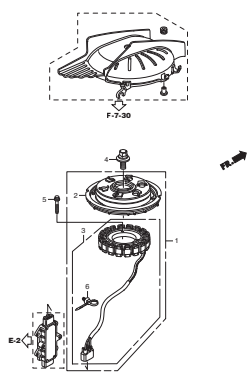

E-20 PLUG TOP COIL

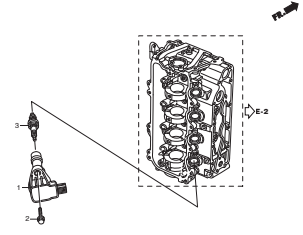

E-20-10 ELECTRONIC CONTROL UNIT

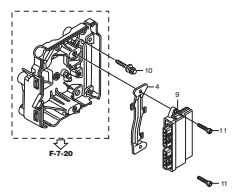

E-21 STARTER MOTOR

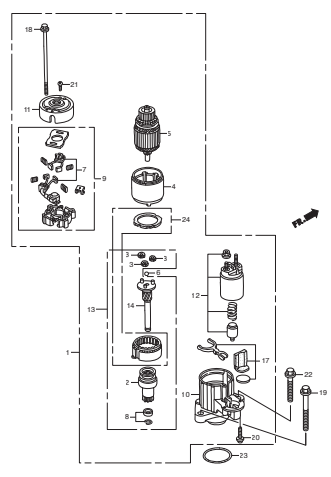

F-2 SHIFT SHAFT

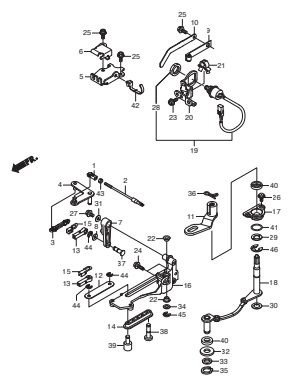

F-3 EXTENSION CASE

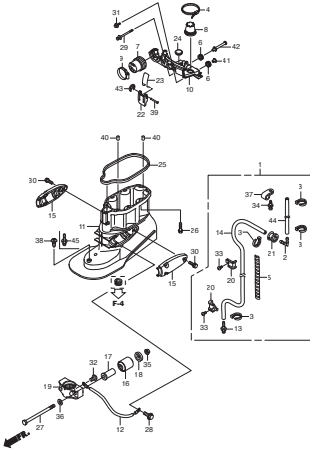

F-3-10 GEAR CASE

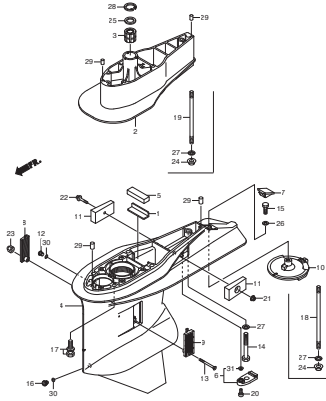

F-3-20 GEAR CASE ASSY.

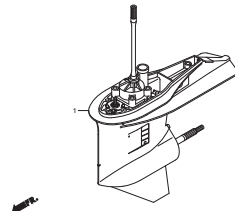

F-3-30 MOUNT CASE

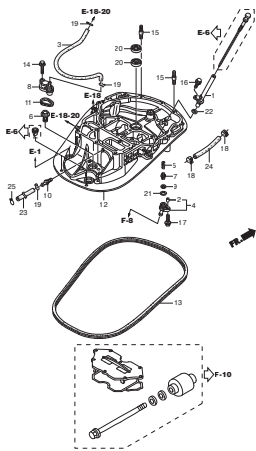

F-4 WATER PUMP/VERTICAL SHAFT

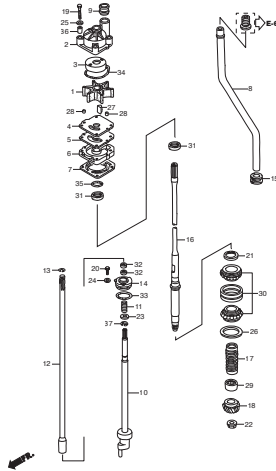

F-5 PROPELLER SHAFT

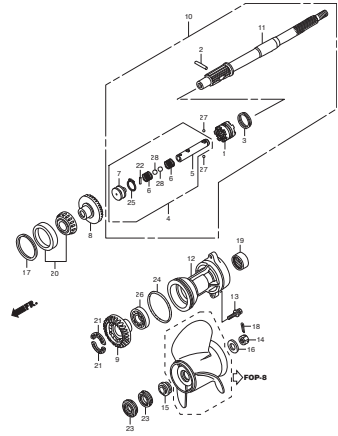

F-6 FUEL TUBE

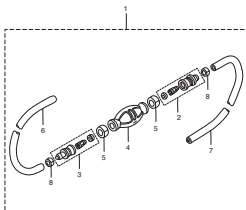

F-7 MAIN WIRE HARNESS

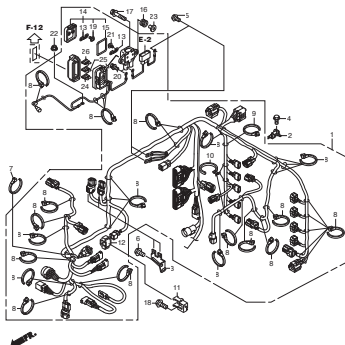

F-7-10 STARTER CABLE

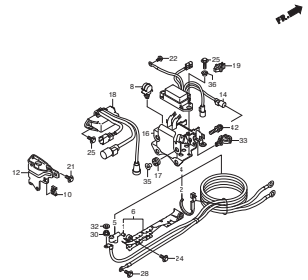

F-7-20 ELECTRONIC PARTS CASE

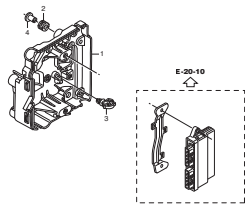

F-7-30 A.C. GENERATOR COVER

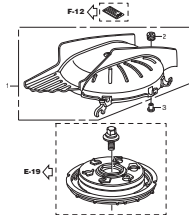

F-8 ENGINE COVER/UNDER COVER

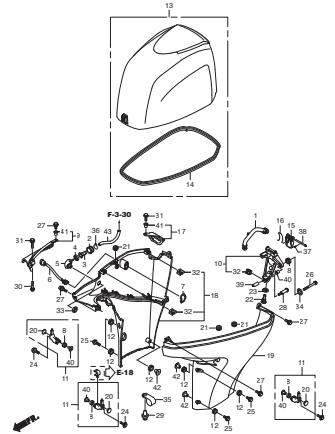

F-10 STERN BRACKET/SWIVEL CASE

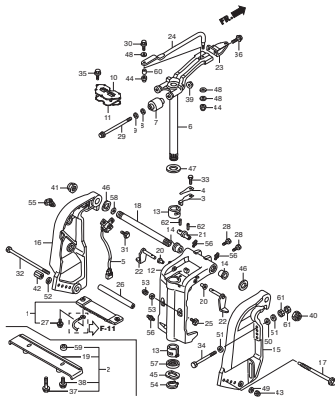

F-11 POWER TRIM-TILT

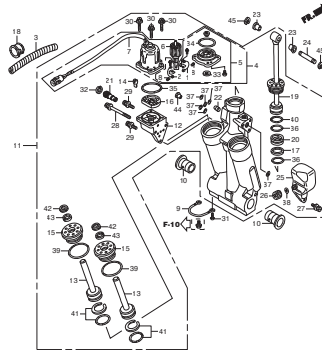

F-12 LABEL

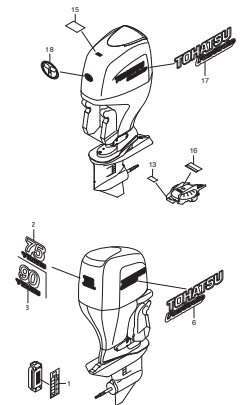

F-13 TOOL

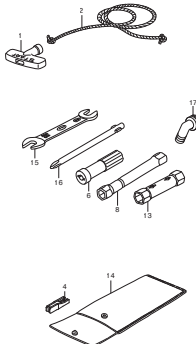

F-15 REMOTE CONTROL(1)

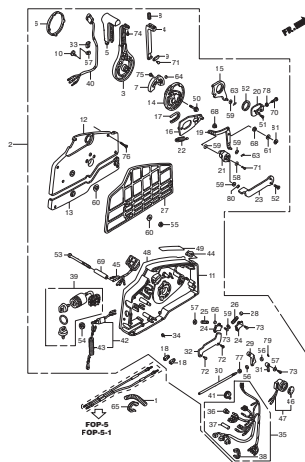

F-15-1 REMOTE CONTROL(2)

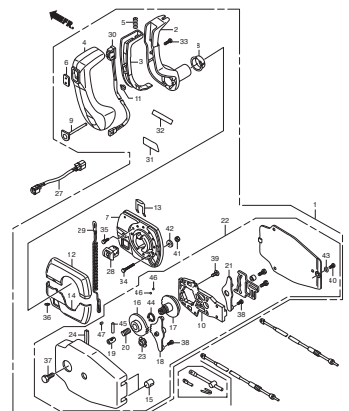

FOP-3 IMPELLER PUMP KIT

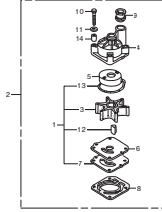

FOP-4 REMOTE CONTROL(TOP MOUNT SINGLE TYPE)(RIGHT)

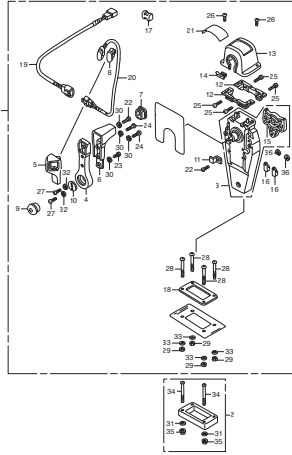

FOP-4-2 REMOTE CONTROL(TOP MOUNT DUAL TYPE)(RIGHT)

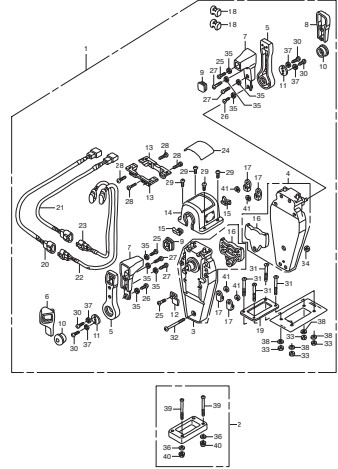

FOP-4-4 REMOTE CONTROL(FLUSH MOUNT TYPE)(RIGHT)

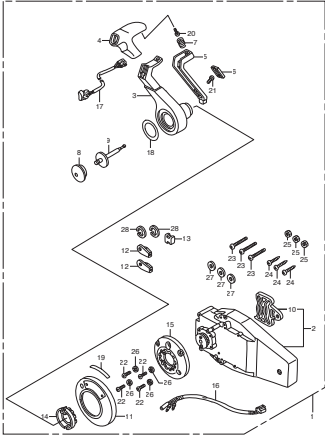

FOP-6 SWITCH PANEL KIT(1)

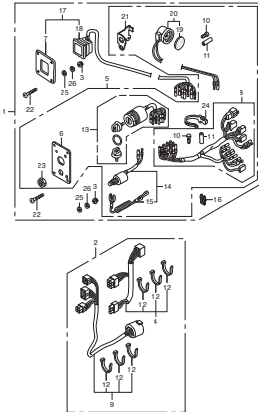

FOP-6-1 SWITCH PANEL KIT(2)

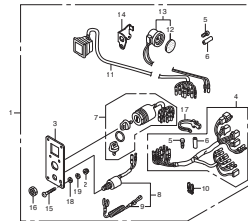

FOP-7 METER

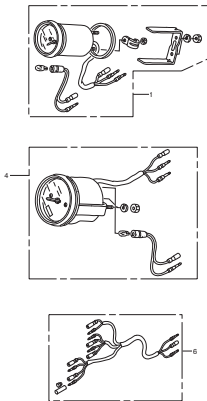

FOP-8 PROPELLER

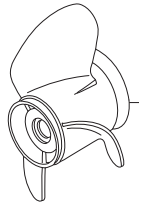

FOP-9 BOLT KIT

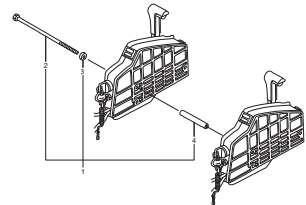

FOP-10 STEERING HANDLE KIT

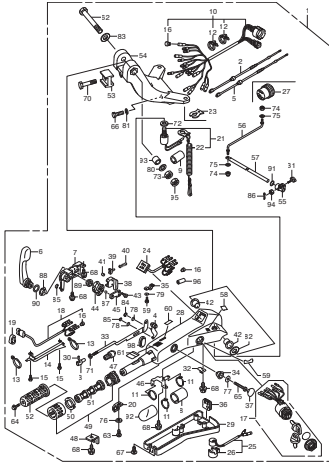

FOP-11 INTERFACE CABLE KIT

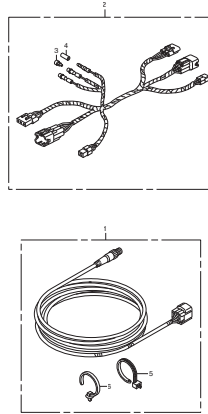

FOP-12 TROLLING CONTROL SWITCH

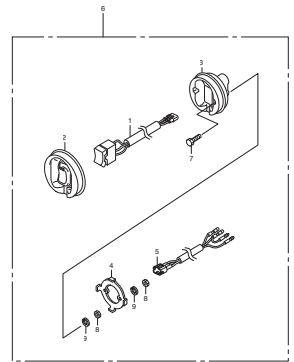

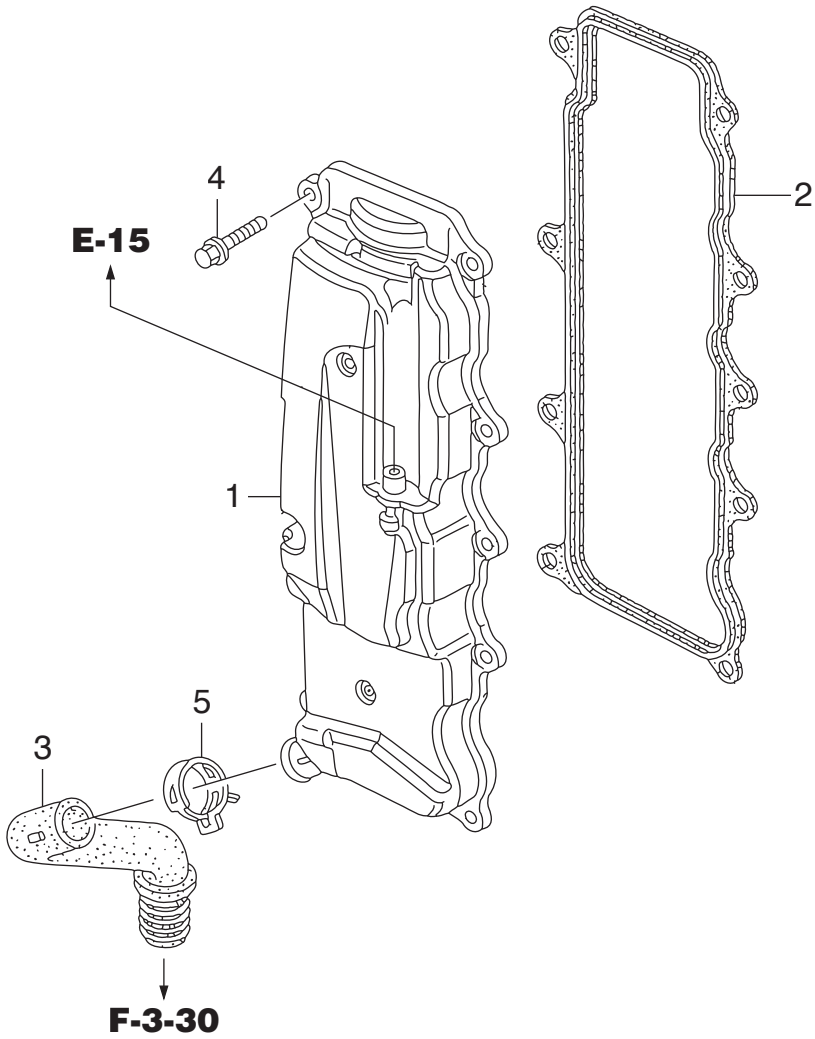

Ref.No.	Part No.	Description	Q' ty		Remarks	
			BET75A	BET90A		
E-2	1	HZV5-12155-000	METAL, ANODE	2	2	
E-2	2	HPJ7-12204-305	GUIDE, IN. VALVE(OS)	8	8	
E-2	3	HPJ7-12205-305	GUIDE, EX. VALVE(OS)	8	8	
E-2	4	HPZ1-12210-004	SEAL A, VALVE STEM(NOK)	8	8	
E-2	5	HZY9-12210-H00ZA	HEAD COMP., CYLINDER	1	1	*NH8* DARK GRAY
E-2	6	HPZ1-12211-004	SEAL B, VALVE STEM(NOK)	8	8	
E-2	7	HZW1-12217-010	BOLT, SEALING, 20MM	2	2	
E-2	8	HZY9-12251-013	GASKET COMP., CYLINDER HEAD	1	1	
E-2	9	HPZA-14820-013	MOTION COMP., LOST		4	
E-2	10	HZZ0-15810-003ZA	VALVE ASSY., SPOOL		1	*NH8* DARK GRAY
E-2	11	HRAA-15815-A02	FILTER ASSY., SPOOL VALVE	1	1	
E-2	12	HZY9-15815-000	COVER ASSY., OIL PATH	1		
E-2	13	HZY9-16717-000	LIFTER, FUEL PUMP	1	1	
E-2	14	HZY9-16896-003	CLAMP B, FUEL TUBE	1	1	
E-2	15	HZY6-19300-003	THERMOSTAT ASSY.	1	1	
E-2	16	HZW9-19315-000	COVER, THERMOSTAT	1	1	
E-2	17	HZW9-19317-000	O-RING, THERMOSTAT COVER	1	1	
E-2	18	HZY9-19361-010	COVER, WATER JACKET	1	1	
E-2	19	HZY9-19371-000	PACKING, EX. WATER JACKET	1	1	COVER
E-2	20	HZY9-31750-003	RECTIFIER ASSY., REGULATOR	1	1	
E-2	21	HZY9-31754-000	PACKING, REGULATOR	1	1	
E-2	22	HZY9-32114-000	BRACKET D, HARNESS CLIP	1	1	
E-2	23	HZY9-35655-H01	SENSOR, OXYGEN	1	1	
E-2	24	HZY3-35673-003	SENSOR ASSY., WATER	1	1	TEMPERATURE
E-2	25	HZY9-35695-003	SENSOR ASSY., TDC	1	1	
E-2	26	HPWA-90008-003	BOLT-WASHER, 9X155	10	10	
E-2	27	HZY9-90011-000	BOLT, FLANGE, 8X95	1	1	
E-2	28	HZY9-90016-000	BOLT, FLANGE, 8X110	1	1	
E-2	29	HZY3-90017-000	BOLT, FLANGE, 6X16	1	1	

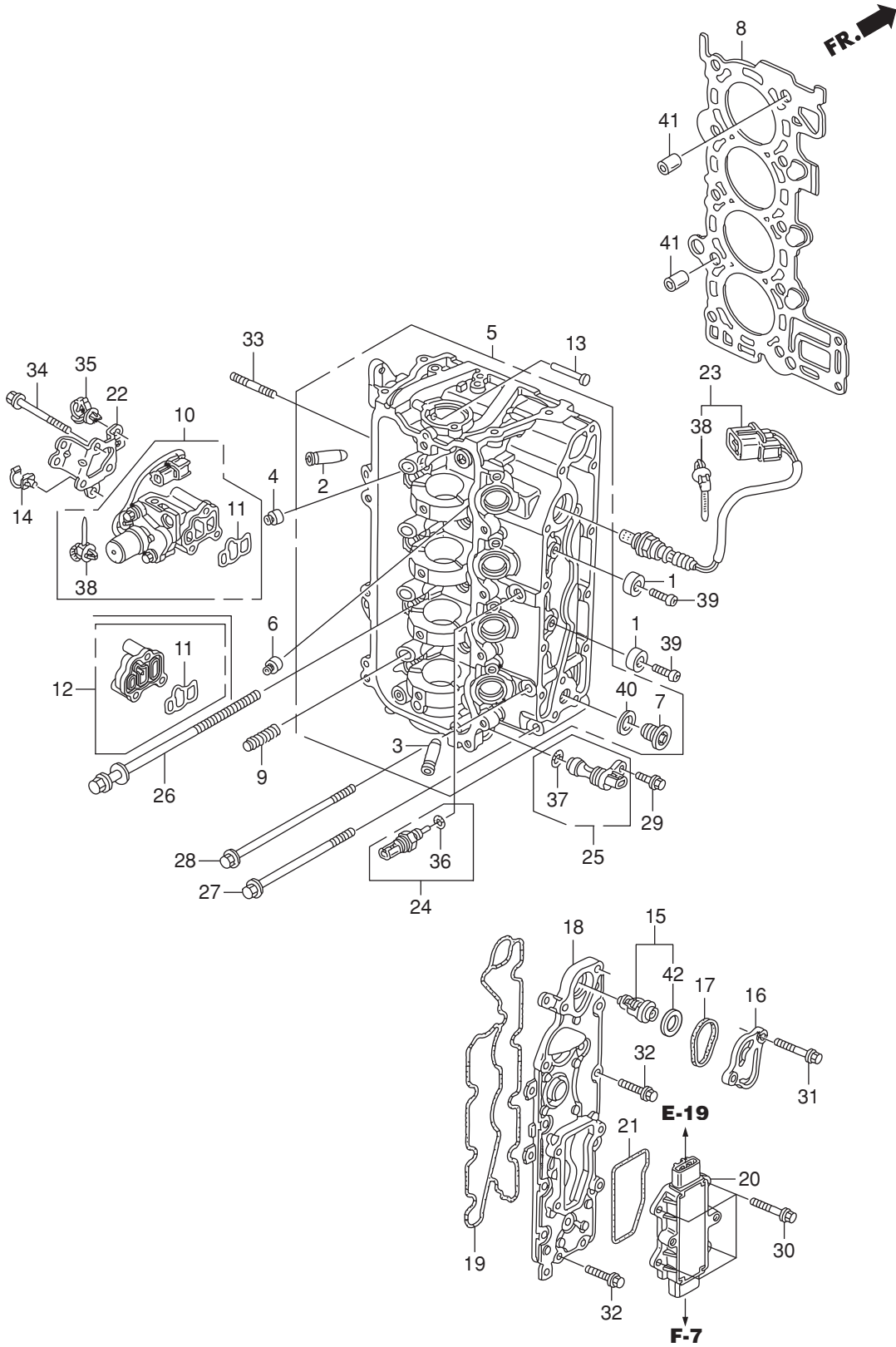

FR. 

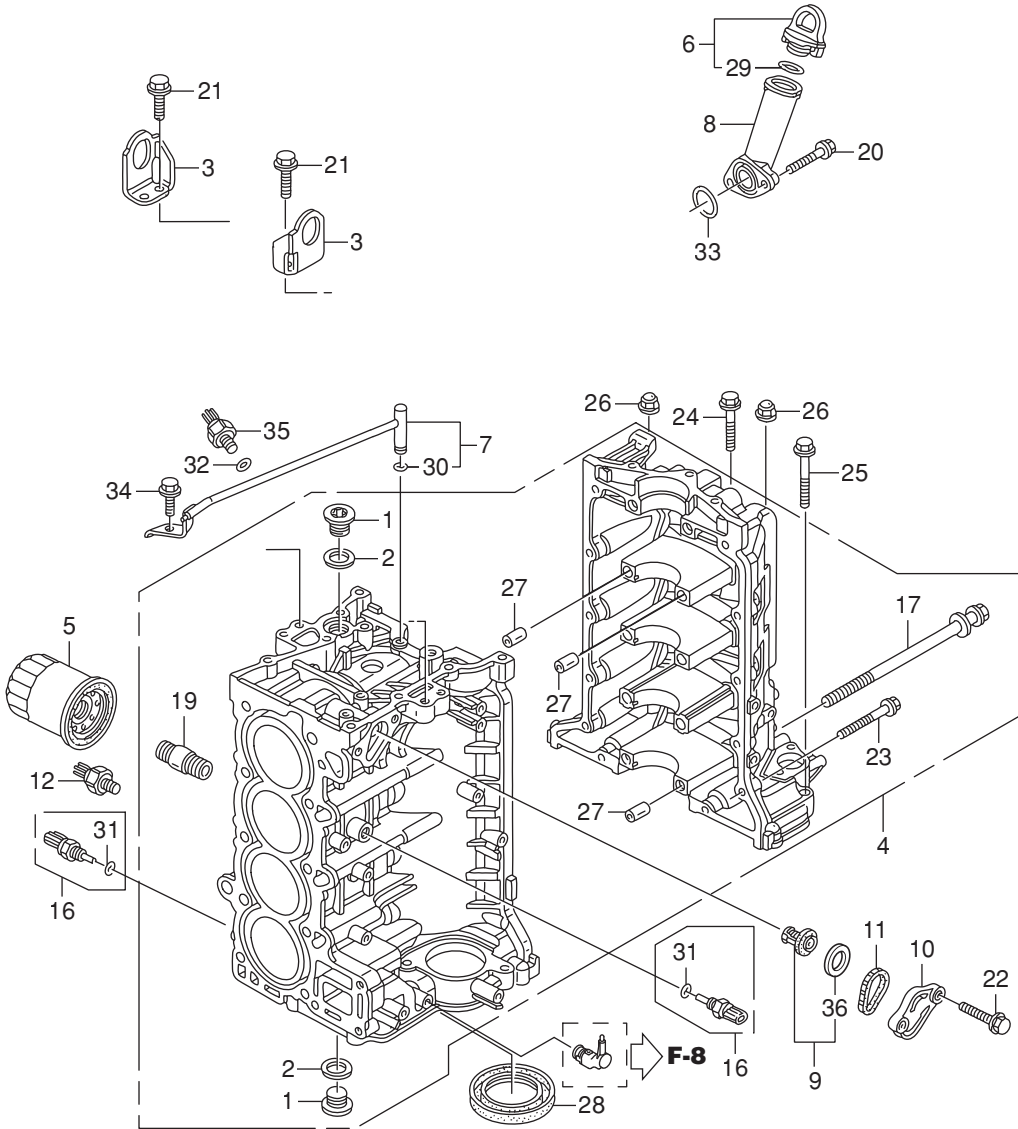

Ref.No.	Part No.	Description	Q' ty		Remarks	
			BET75A	BET90A		
E-3	1	HPWA-11106-300	BOLT, SEALING, 24MM	2	2	
E-3	2	HPWA-11107-300	WASHER, SEALING, 24MM	2	2	
E-3	3	HZY9-11911-000	HANGER, ENGINE	2	2	
E-3	4	HZY9-12000-406ZA	BLOCK ASSY., CYLINDER	1	1	*NH8* DARK GRAY
E-3	5	HRTA-15400-004	CARTRIDGE, OIL FILTER	1	1	(TOYO ROKI)
E-3	6	HZY9-15600-000	CAP ASSY., OIL FILLER	1	1	
E-3	7	HZY9-15612-000	PIPE, OIL	1	1	
E-3	8	HZY9-15631-000	EXTENSION, OIL FILLER	1	1	
E-3	9	HZW9-19300-003	THERMOSTAT ASSY.	1	1	
E-3	10	HZY9-19315-H00	COVER, THERMOSTAT	1	1	
E-3	11	HZW9-19317-000	O-RING, THERMOSTAT COVER	1	1	
E-3	12	HRGA-30530-004	SENSOR COMP., KNOCK		1	
E-3	16	HZY3-35673-003	SENSOR ASSY., WATER	2	2	TEMPERATURE
E-3	17	HZY9-90008-003	BOLT-WASHER, 10X105	10	10	
E-3	19	HPH1-90015-013	HOLDER, OIL FILTER	1	1	
E-3	20	HZW9-90016-000	BOLT, FLANGE, 6X25	2	2	
E-3	21	HZY3-90026-000	BOLT, FLANGE, 8X20	4	4	
E-3	22	HZY3-90030-000	BOLT, FLANGE, 6X22	2	2	
E-3	23	HZY3-90031-000	BOLT, FLANGE, 6X32	12	12	
E-3	24	HZY3-90054-000	BOLT, FLANGE, 8X35	1	1	
E-3	25	HHW1-90120-671	BOLT, FLANGE, 8X45	2	2	
E-3	26	HZY9-90201-000	NUT, FLANGE CAP, 8MM	2	2	
E-3	27	HPD2-90701-000	DOWEL PIN, 12X14	10	10	
E-3	28	HPNA-91214-014	OIL SEAL, 80X98X10(ARAI)	1	1	
E-3	29	HMAL-91302-601	O-RING, 18.1X3.6	1	1	
E-3	30	HZY6-91305-003	O-RING, 6.5X1.5	1	1	
E-3	31	HPNA-91307-003	O-RING, 9.5X1.9	2	2	
E-3	32	HPR3-91319-003	O-RING, 13X1.5(ARAI)	1	1	
E-3	33	HPF4-91324-004	O-RING, 28.3X2.4(NOK)	1	1	

FR. 

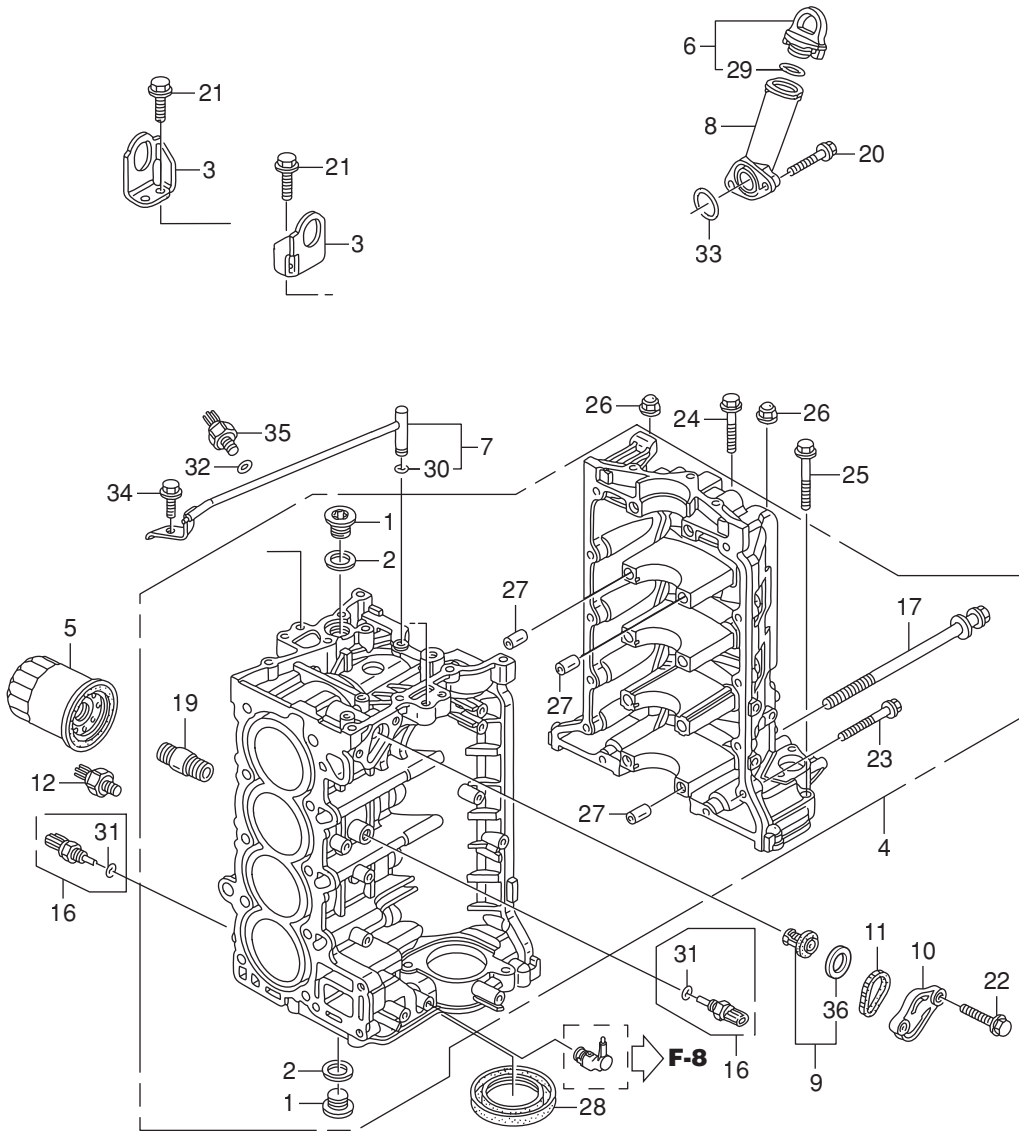

FR. 

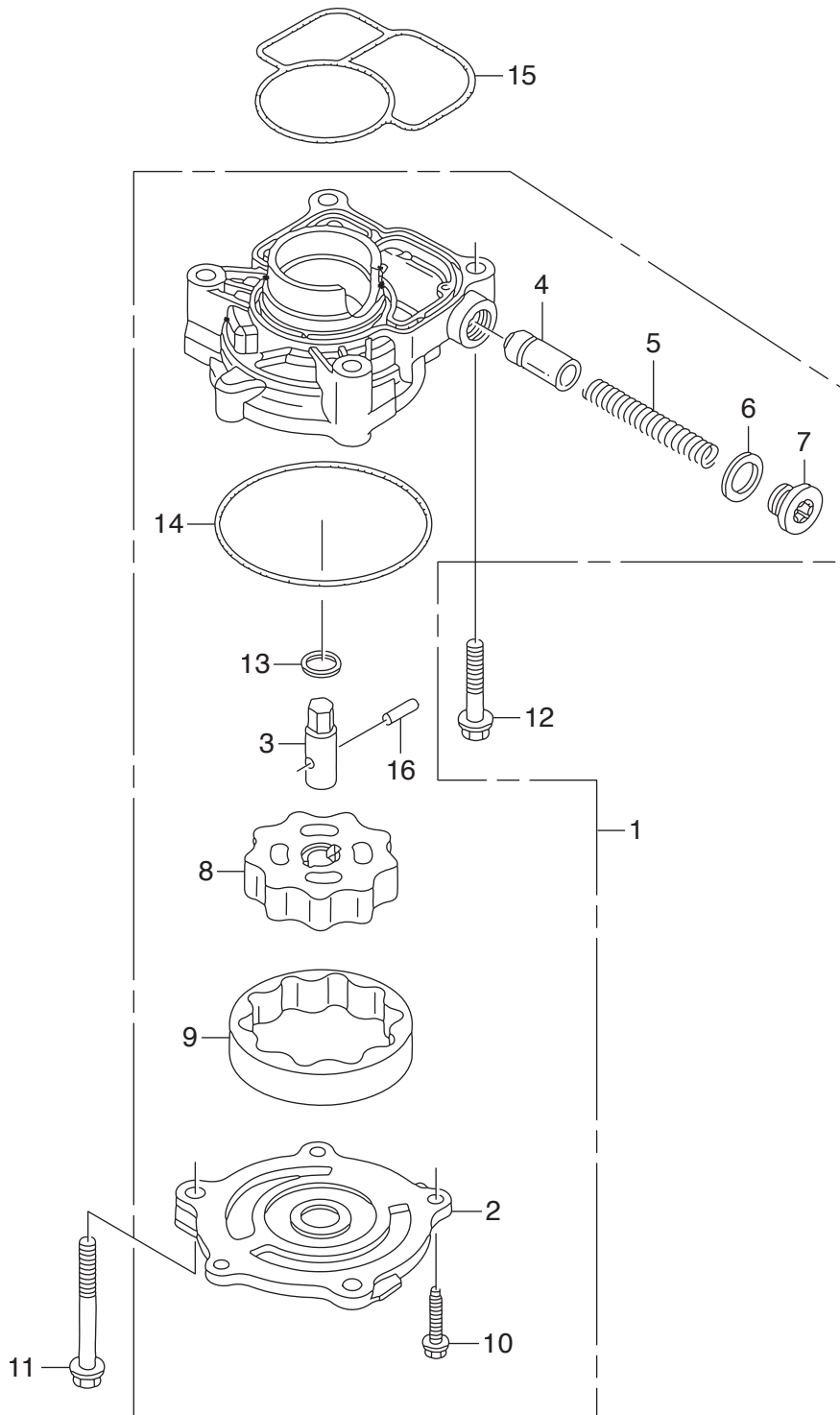

E-6 OIL CASE

FR. 

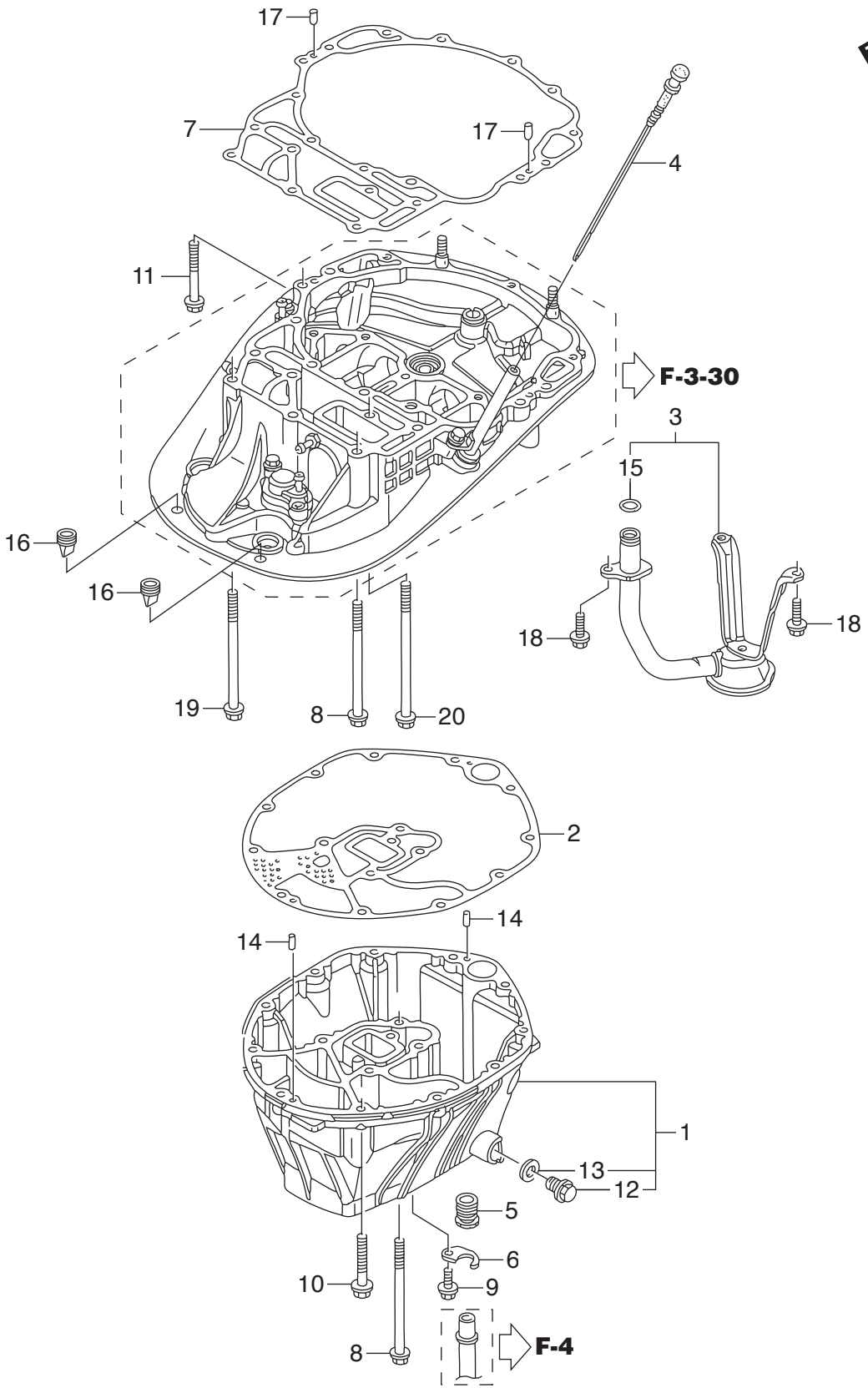

FR. 

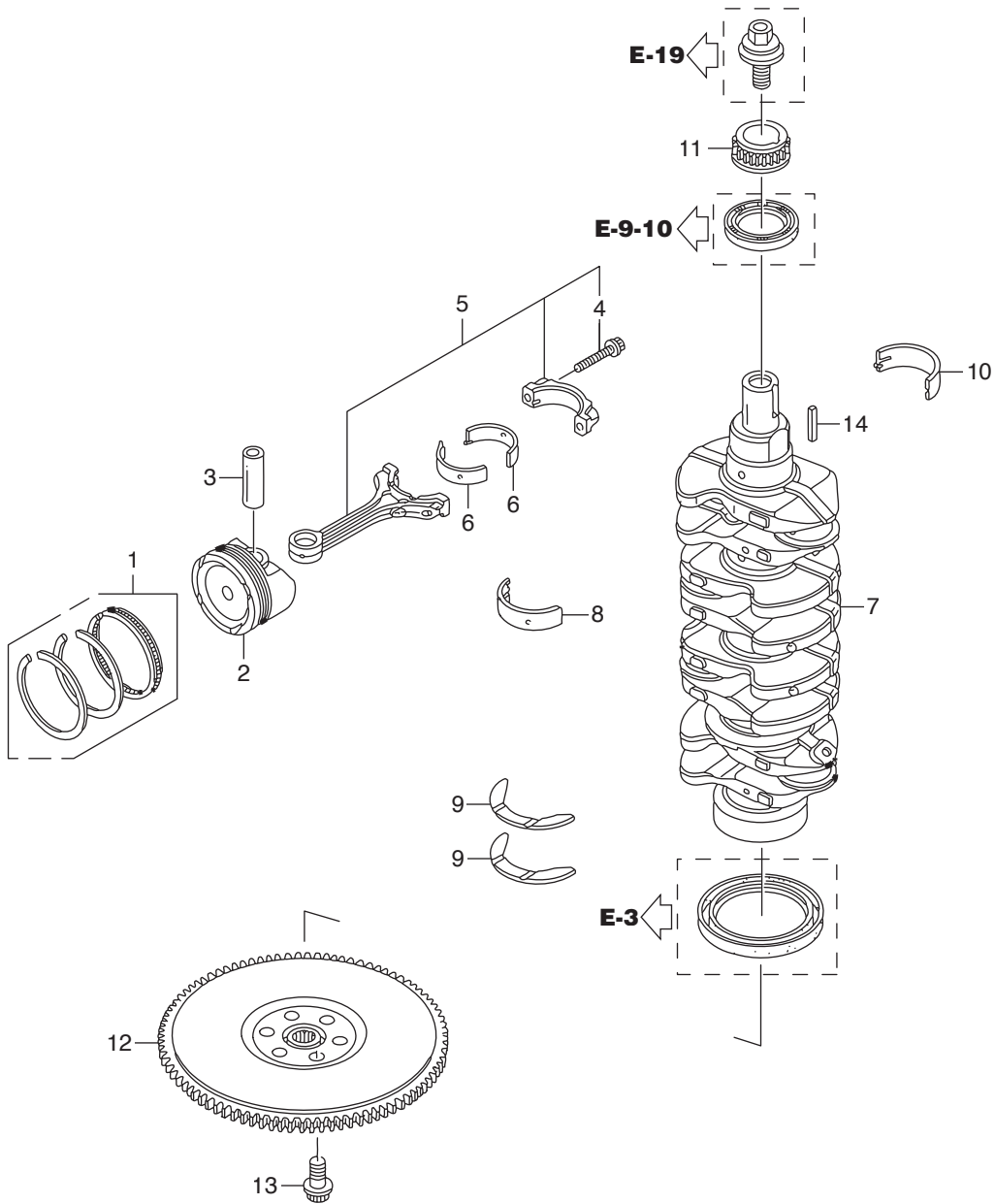

Ref.No.	Part No.	Description	Q' ty		Remarks	
			BET75A	BET90A		
E-7	1	HZY9-13010-H00	RING SET, PISTON(STD.)	4	4	
E-7	1	HZY9-13011-010	RING SET, PISTON(0.25)	4	4	
E-7	2	HZY9-13101-H00	PISTON(STD.)	4	4	
E-7	2	HZZ0-13102-000	PISTON(0.25)	4	4	
E-7	3	HPWA-13111-000	PIN, PISTON	4	4	
E-7	4	HPWA-13204-003	BOLT, CONNECTING ROD	8	8	
E-7	5	HZY9-13210-010	ROD COMP., CONNECTING	4	4	
E-7	6	HPWA-13211-003	BEARING A, CONNECTING ROD	8	8	(BLUE)(DAIDO)
E-7	6	HPWA-13212-003	BEARING B, CONNECTING ROD	8	8	(BLACK)(DAIDO)
E-7	6	HPWA-13213-003	BEARING C, CONNECTING ROD	8	8	(BROWN)(DAIDO)
E-7	6	HPWA-13214-003	BEARING D, CONNECTING ROD	8	8	(GREEN)(DAIDO)
E-7	6	HPWA-13215-003	BEARING E, CONNECTING ROD	8	8	(YELLOW)(DAIDO)
E-7	6	HPWA-13216-003	BEARING F, CONNECTING ROD	8	8	(PINK)(DAIDO)
E-7	6	HPWA-13217-003	BEARING G, CONNECTING ROD(REDF)	8	8	(DAIDO)
E-7	7	HZY9-13310-010	CRANKSHAFT COMP.	1	1	
E-7	8	HPWA-13322-003	BEARING B, MAIN UPPER(BLACK)	5	5	(DAIDO)
E-7	8	HPWA-13323-003	BEARING C, MAIN UPPER(BROWN)	5	5	(DAIDO)
E-7	8	HPWA-13324-003	BEARING D, MAIN UPPER(GREEN)	5	5	(DAIDO)
E-7	8	HPWA-13325-003	BEARING E, MAIN UPPER(YELLOW)	5	5	(DAIDO)
E-7	8	HPWA-13326-003	BEARING F, MAIN UPPER(PINK)	5	5	(DAIDO)
E-7	8	HPWA-13327-003	BEARING G, MAIN UPPER(REDF)	5	5	(DAIDO)
E-7	8	HPWA-13328-003	BEARING H, MAIN UPPER(WHITE)	5	5	(DAIDO)
E-7	9	HZY9-13331-003	WASHER, THRUST	2	2	
E-7	10	HPWA-13342-003	BEARING B, MAIN LOWER(BLACK)	5	5	(DAIDO)
E-7	10	HPWA-13343-003	BEARING C, MAIN LOWER(BROWN)	5	5	(DAIDO)
E-7	10	HPWA-13344-003	BEARING D, MAIN LOWER(GREEN)	5	5	(DAIDO)
E-7	10	HPWA-13345-003	BEARING E, MAIN LOWER(YELLOW)	5	5	(DAIDO)
E-7	10	HPWA-13346-003	BEARING F, MAIN LOWER(PINK)	5	5	(DAIDO)
E-7	10	HPWA-13347-003	BEARING G, MAIN LOWER(REDF)	5	5	(DAIDO)

FR. 

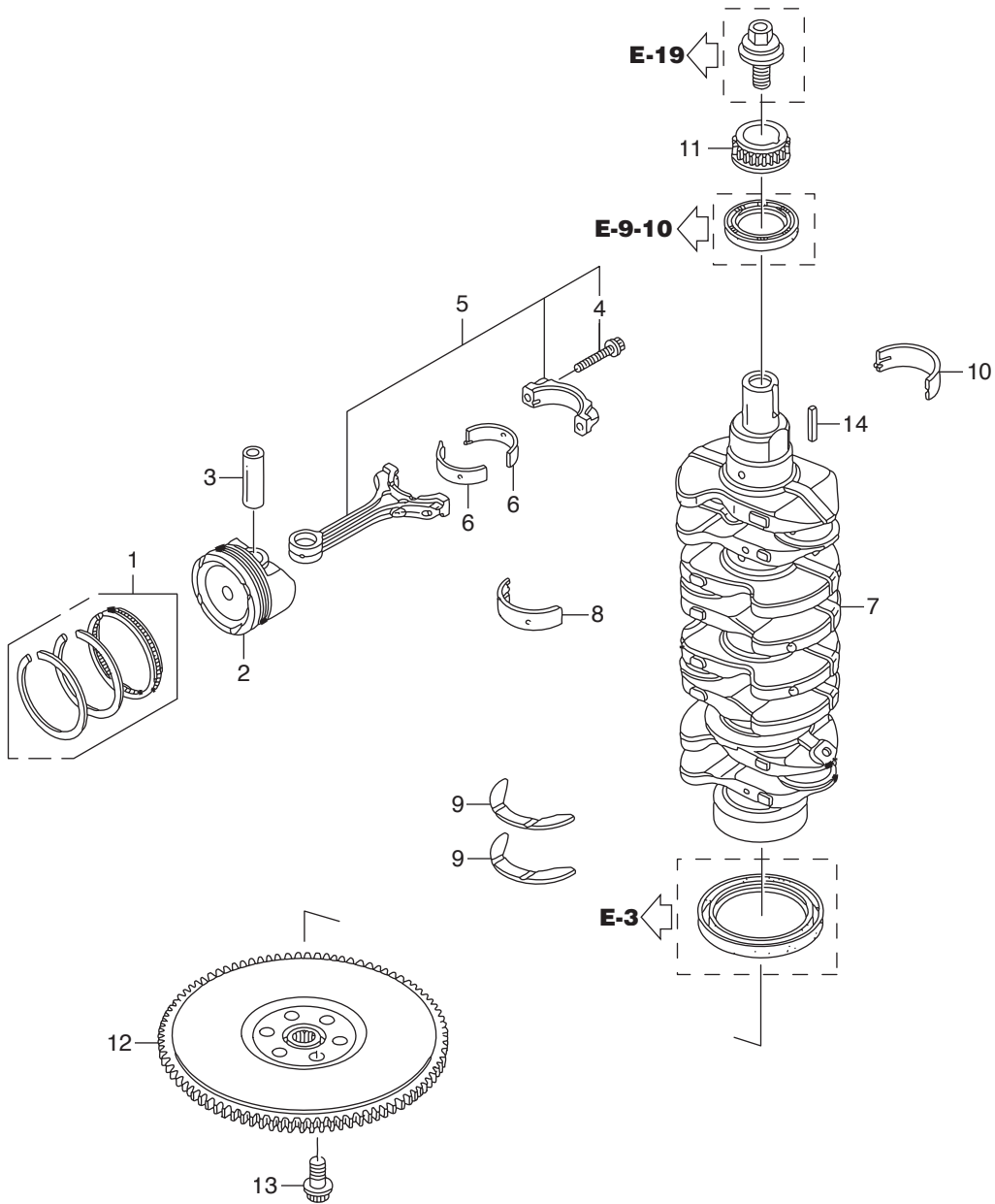

FR. 

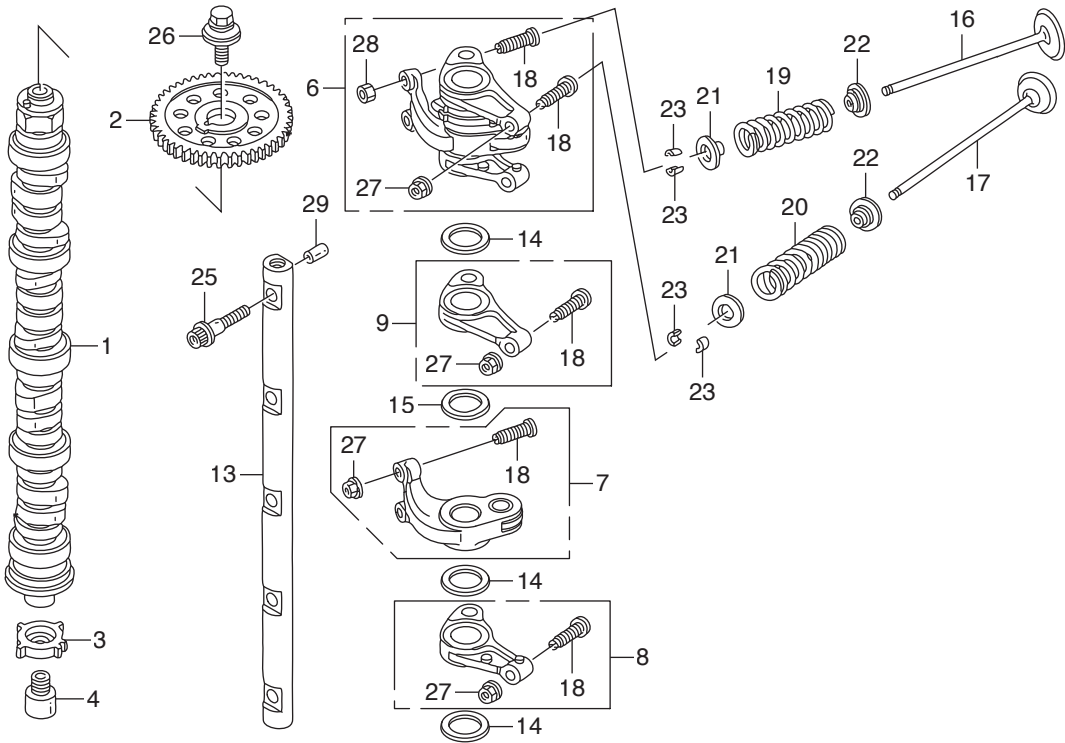
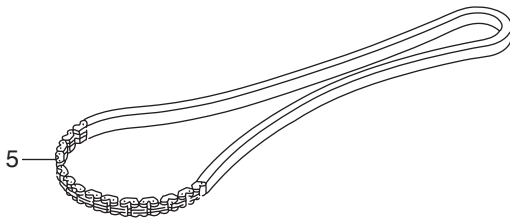
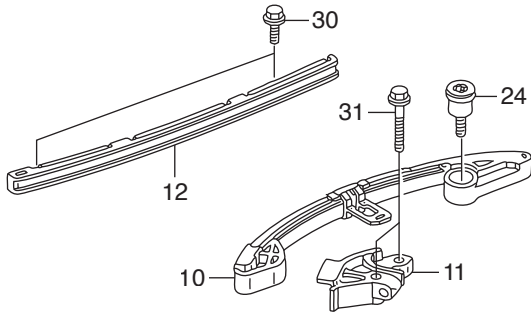

Ref.No.	Part No.	Description	Q' ty		Remarks
			BET75A	BET90A	
E-9	1	HZY9-14110-000	CAMSHAFT COMP.	1	
E-9	1	HZZ0-14110-000	CAMSHAFT COMP.		1
E-9	2	HRB0-14211-003	SPROCKET, CAM CHAIN DRIVEN	1	1 (46T)
E-9	3	HPWA-14221-003	PLATE, TDC PULSER	1	1
E-9	4	HZY9-14222-000	BOLT, TDC PULSER PLATE	1	1
E-9	5	HRB1-14401-003	CHAIN(132L)	1	1
E-9	6	HZZ0-14420-000	ARM ASSY., ROCKER		4
E-9	7	HZY9-14430-000	ARM COMP., IN. VALVE ROCKER	4	
E-9	8	HZY9-14441-000	ARM COMP., EX. ROCKER(A)	4	
E-9	9	HZY9-14442-000	ARM COMP., EX. ROCKER(B)	4	
E-9	10	HZY9-14510-003	TENSIONER COMP., CAM CHAIN	1	1
E-9	11	HZY9-14512-000	SLIDER COMP., CAM CHAIN	1	1 TENSIONER
E-9	12	HRB1-14530-004	GUIDE COMP., CAM CHAIN	1	1
E-9	13	HPWC-14631-010	SHAFT COMP., ROCKER ARM	1	1
E-9	14	HPWA-14647-000	WASHER, THRUST	12	
E-9	15	HPY3-14647-000	WASHER, IN. WAVE	4	
E-9	16	HRB0-14711-000	VALVE, IN.	8	8
E-9	17	HPWC-14721-010	VALVE, EX.	8	8
E-9	18	HPM3-14744-000	SCREW, TAPPET ADJUSTING	16	16
E-9	19	HZY9-14751-H01	SPRING, IN. VALVE	8	8
E-9	20	HZY9-14752-003	SPRING, EX. VALVE	8	8
E-9	21	HRGA-14765-000	RETAINER, VALVE SPRING	16	16
E-9	22	HP08-14775-000	SEAT, VALVE SPRING	16	16
E-9	23	HRGM-14781-A01	COTTER, VALVE(FUJI VALVE)	32	32
E-9	24	HPNA-90003-000	BOLT, TENSIONER PIVOT	1	1
E-9	25	HPWC-90006-003	BOLT, ROCKER ARM SHAFT	5	5
E-9	26	HRNA-90031-A01	BOLT-WASHER, 10X30	1	1
E-9	27	HPM3-90206-004	NUT, TAPPET ADJUSTING	16	8 (TOKAI TRW)
E-9	28	HPT0-90206-004	NUT, TAPPET ADJUSTING		8

FR. 

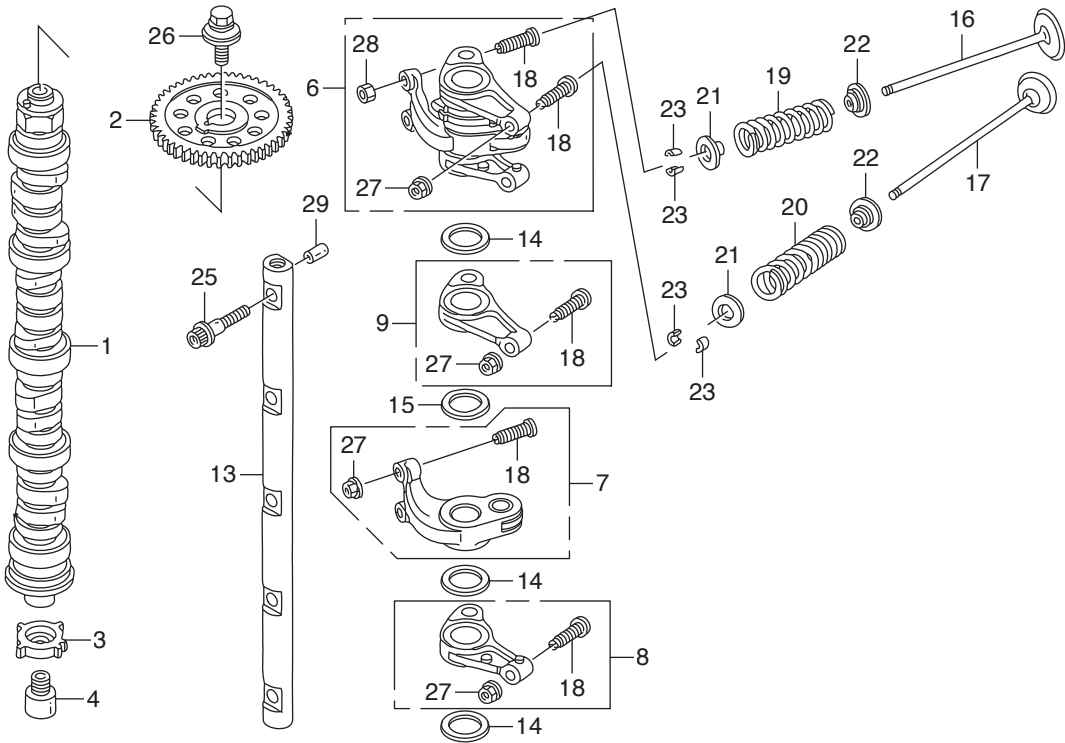
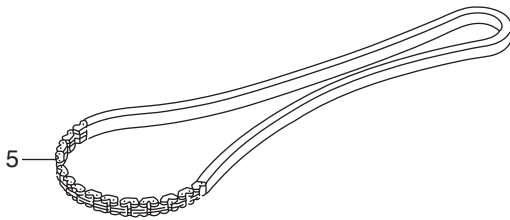
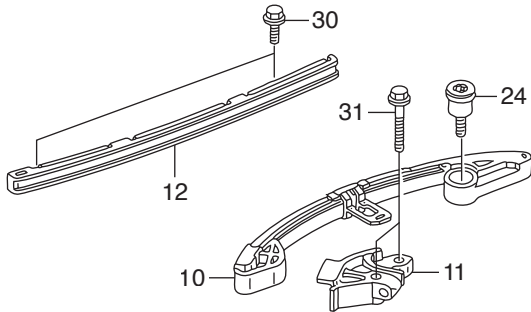

FR. 

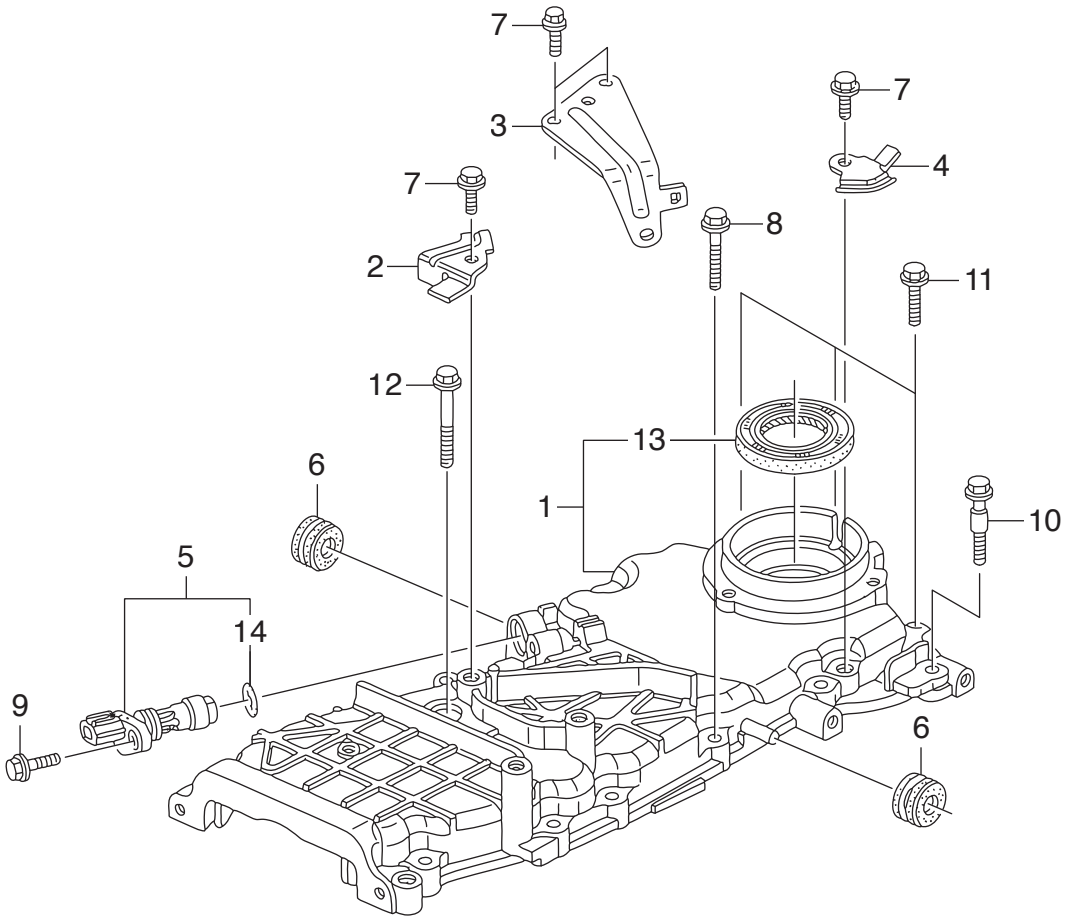

Ref.No.	Part No.	Description	Q' ty		Remarks	
			BET75A	BET90A		
E-14	1	HZY9-16450-003	INJECTOR ASSY., FUEL	4	4	
E-14	2	HZY9-16451-000	CLIP, INJECTOR	2	2	
E-14	3	HZY9-16620-010	LINE COMP., FUEL	1	1	
E-14	4	HPH3-16638-S00	INSULATOR, FUEL PIPE	2	2	
E-14	5	HZY9-16733-000	GROMMET, VAPOR SEPARATOR	2	2	
E-14	6	HZY3-16752-A00	JOINT, FUEL PIPE	1	1	
E-14	7	HPWA-17105-007	PACKING, INTAKE MANIFOLD	4	4	
E-14	8	HZY6-17109-000	PACKING, THROTTLE BODY	1	1	
E-14	9	HZY9-17110-003	MANIFOLD COMP., INLET	1	1	
E-14	10	HZY9-36550-003	VALVE ASSY., ELECTRONIC AIR	1	1	CONTROL
E-14	11	HZY6-36551-003	PACKING, ELECTRONIC AIR	1	1	CONTROL VALVE
E-14	12	HZY9-90003-000	BOLT, STUD, 6X40	2	2	
E-14	13	HZW1-90014-000	BOLT-WASHER, 8X35	2	2	
E-14	14	HZY3-90042-000	BOLT, FLANGE, 6X10	4	4	
E-14	15	HZY3-90054-000	BOLT, FLANGE, 8X35	3	3	
E-14	16	HZW4-90126-000	BOLT, FLANGE, 8X45	2	2	
E-14	17	HZY3-90205-000	NUT, FLANGE, 8MM	2	2	
E-14	18	HZW2-90301-F00	NUT, FLANGE, 6MM	2	2	
E-14	19	HMJ0-91301-003	O-RING, 7.8X1.9(ARAI)	2	2	
E-14	20	HPLC-91301-000	O-RING, 7.47X3.6	4	4	
E-14	21	HPNA-91302-003	O-RING, 7.45X3.61(NOK)	4	4	
E-14	22	HZW1-91554-000	COLLAR, 8.5X14.5	2	2	

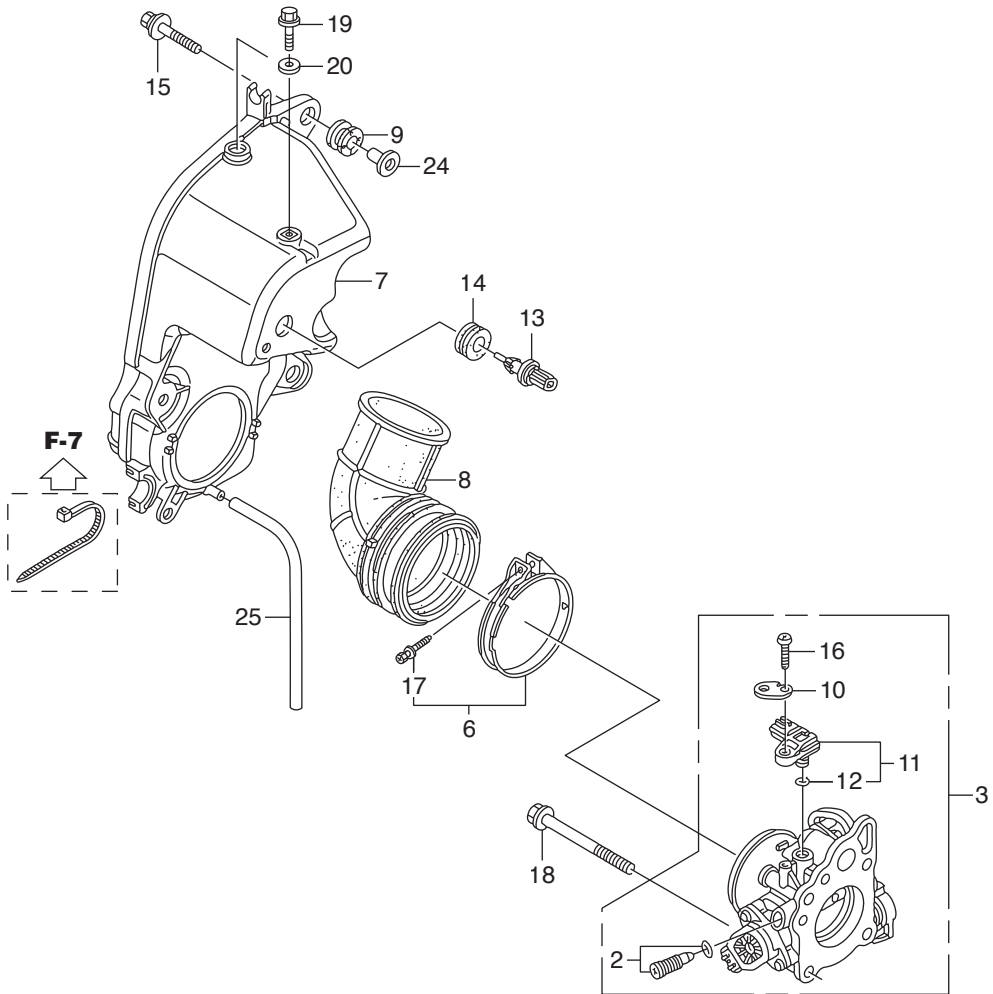
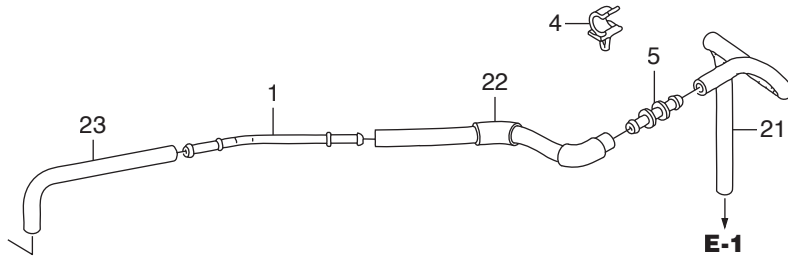

FR.

Ref.No.	Part No.	Description	Q' ty		Remarks	
			BET75A	BET90A		
E-15	1	HZY9-15171-000	PIPE, BREATHER	1	1	
E-15	2	HZY6-16016-003	SCREW SET	1	1	
E-15	3	HZY9-16400-H01	THROTTLE BODY ASSY.	1	1	
E-15	4	HZY9-16896-003	CLAMP B, FUEL TUBE	1	1	
E-15	5	HMR5-16966-000	JOINT, FUEL TUBE	1	1	
E-15	6	HZY9-17315-000	BAND, AIR FLOW	1	1	
E-15	7	HZY9-17371-000	CASE COMP., SILENCER	1		
E-15	7	HZY9-17371-H00	CASE COMP., SILENCER		1	
E-15	8	HZY9-17374-000	GROMMET, SILENCER	1	1	
E-15	9	HZY9-30419-003	GROMMET, ELECTRONIC PARTS CASE	2	2	
E-15	10	HZY3-32128-000	BRACKET, SENSOR CORD	1	1	
E-15	11	HRNA-37830-A01	SENSOR ASSY., MAP	1	1	
E-15	12	HPGK-37835-A01	O-RING	1	1	
E-15	13	HPLC-37880-004	SENSOR ASSY., AIR TEMP	1		(MATSUSHITA DENSHI)
E-15	13	HRE1-37880-Z01	SENSOR ASSY., AIR TEMP		1	
E-15	14	HP2A-37881-000	GROMMET, TA SENSOR	1	1	
E-15	15	HZW2-90003-000	BOLT-WASHER, 6X27(CT200)	2	2	
E-15	16	HZY6-90006-000	SCREW, PAN, 5X18	1	1	
E-15	17	HZY9-90017-000	BOLT-WASHER, 5X30	1	1	
E-15	18	HZV1-90127-010	BOLT, FLANGE, 8X60	4	4	
E-15	19	HZW4-90169-000	BOLT, FLANGE,(SH)6X25	1	1	
E-15	20	HZY3-90508-000	WASHER, PLAIN, 6MM	1	1	
E-15	21	HZY9-91403-000	TUBE A, BREATHER	1	1	
E-15	22	HZY9-91404-000	TUBE B, BREATHER	1	1	
E-15	23	HZY9-91405-000	TUBE C, BREATHER	1	1	
E-15	24	HZV5-91553-010	COLLAR, C.D.I. UNIT CASE	2	2	
E-15	25	HCO-95003-07019-31	TUBE, VINYL, 4X7X190	1	1	(HC-95003-07001-60M)

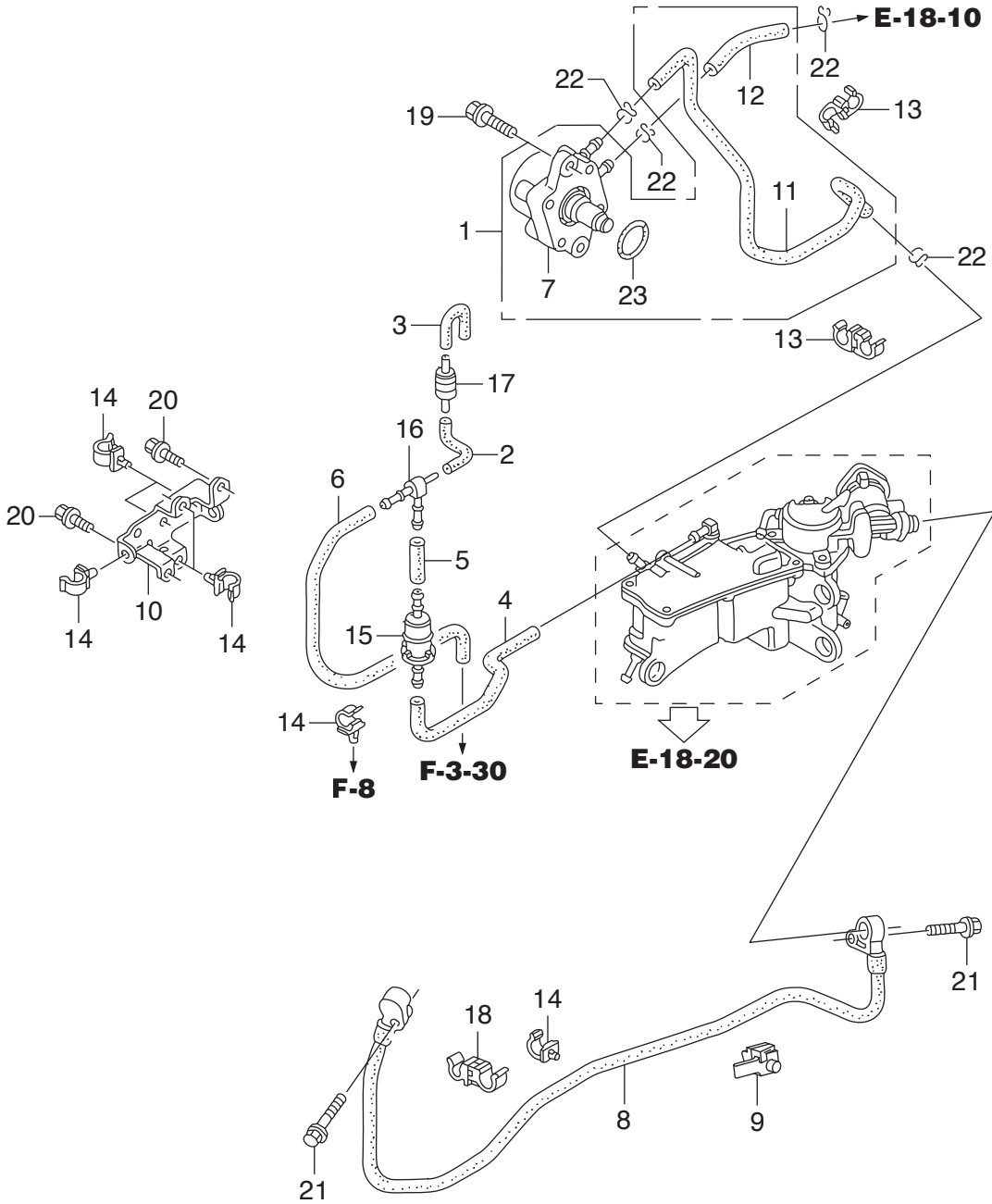

Ref.No.	Part No.	Description	Q' ty		Remarks	
			BET75A	BET90A		
E-18	1	HZY9-06167-000	PUMP ASSY KIT, FUEL	1	1	
E-18	2	HZY9-16195-000	TUBE A, CHECK VALVE	1	1	
E-18	3	HZY9-16196-000	TUBE B, CHECK VALVE	1	1	
E-18	4	HZY9-16197-000	TUBE A, AIR VENT	1	1	
E-18	5	HZY9-16198-000	TUBE B, AIR VENT	1	1	
E-18	6	HZY9-16199-000	TUBE C, AIR VENT	1	1	
E-18	7	HZY9-16700-013	PUMP ASSY., FUEL	1	1	
E-18	8	HZY9-16755-003	HOSE COMP., FUEL	1	1	
E-18	9	HZY9-16756-000	GROMMET, FUEL HOSE	1	1	
E-18	10	HZY9-16816-000	BRACKET, FUEL TUBE CLAMP	1	1	
E-18	11	HZY9-16881-010	TUBE D, FUEL	1	1	
E-18	12	HZY9-16891-000	TUBE E, FUEL	1	1	
E-18	13	HZY9-16895-003	CLAMP A, FUEL TUBE	2	2	
E-18	14	HZY9-16896-003	CLAMP B, FUEL TUBE	7	7	
E-18	15	HZV4-16910-015	STRAINER COMP., FUEL	1	1	
E-18	16	HZY6-19269-000	T-JOINT	1	1	
E-18	17	HZY6-36135-003	VALVE, CHECK	1	1	
E-18	18	HP3F-36533-A01	CLAMP, OXYGEN SENSOR	1	1	
E-18	19	HZW9-90003-000	BOLT, FLANGE, 6X22	2	2	
E-18	20	HZW9-90011-000	BOLT, FLANGE, 6X14(CT200)	2	2	
E-18	21	HZW9-90016-000	BOLT, FLANGE, 6X25	2	2	
E-18	22	HZV0-90604-000	CLIP, TUBE(B12)	4	4	
E-18	23	HZW9-91303-000	O-RING, 31.2X2.4	1	1	

FR. 

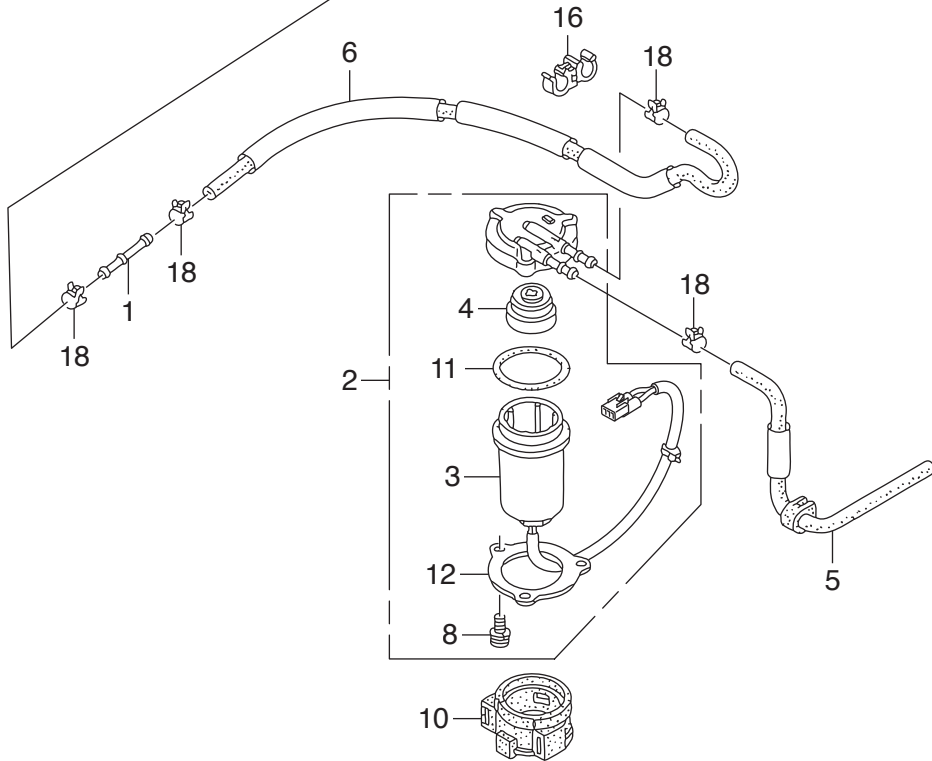
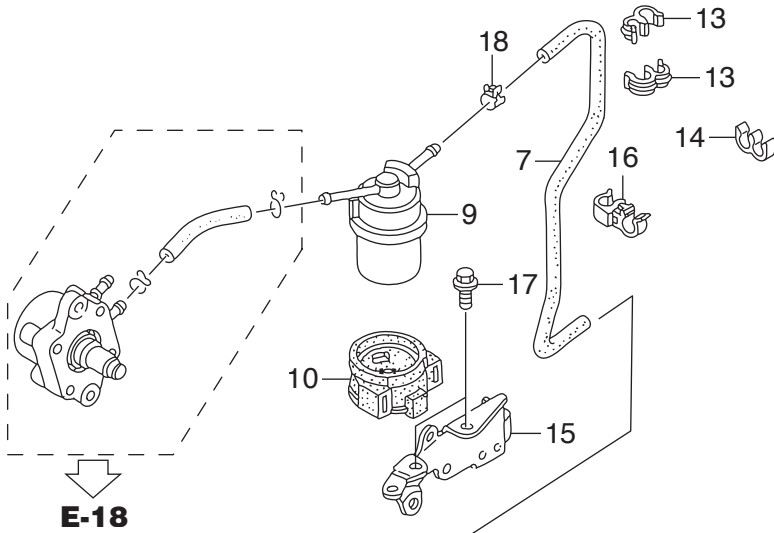

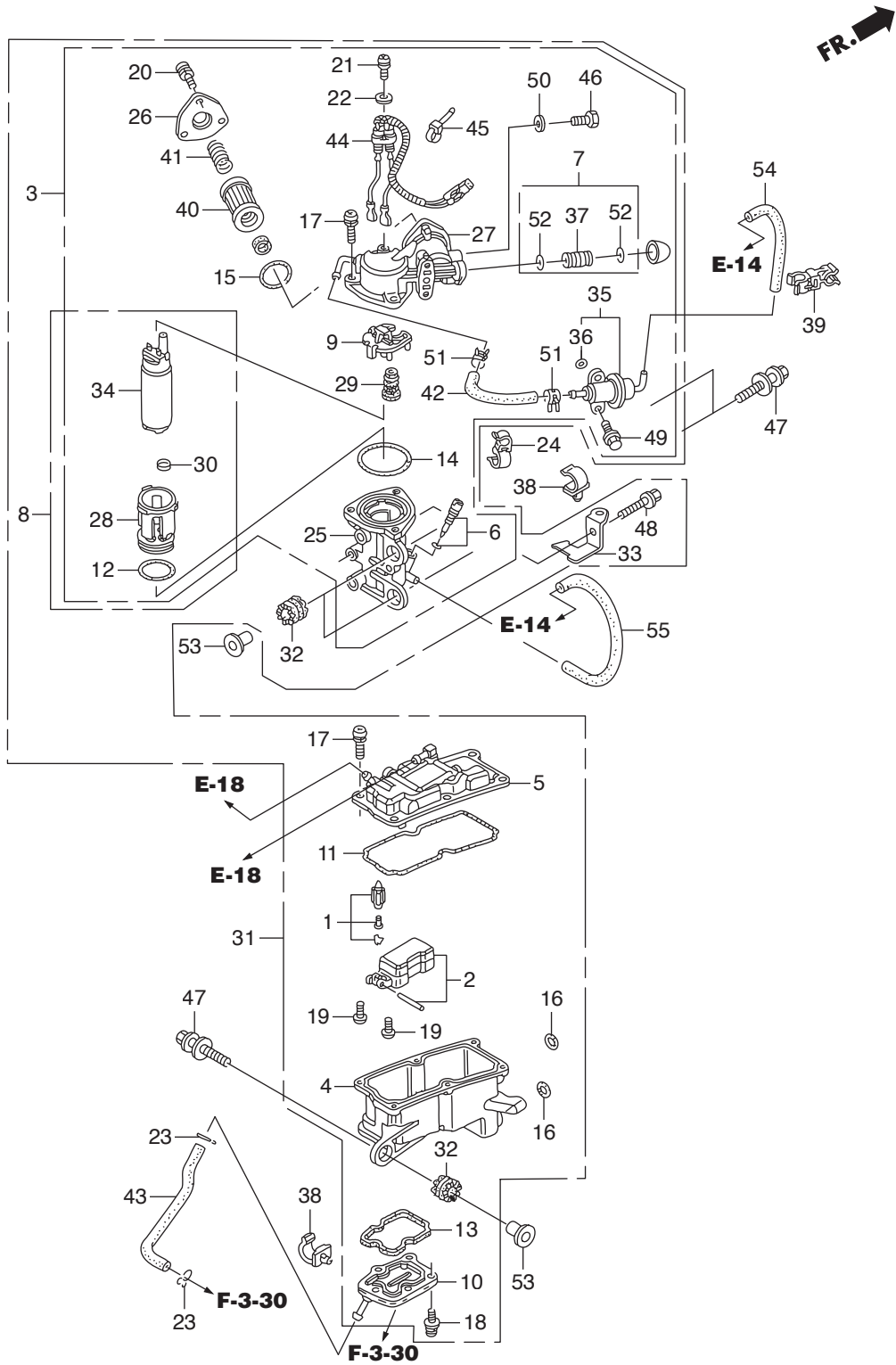

Ref.No.	Part No.	Description	Q' ty		Remarks	
			BET75A	BET90A		
E-18-20	1	HZY3-16011-A01	VALVE SET, FLOAT	1	1	
E-18-20	2	HZY9-16013-000	FLOAT SET	1	1	
E-18-20	3	HZY9-16017-040	PUMP UNIT, FUEL(A)	1	1	
E-18-20	4	HZY9-16019-003	BODY	1	1	
E-18-20	5	HZY9-16020-013	COVER COMP.	1	1	
E-18-20	6	HZY3-16024-000	SCREW SET, DRAIN	1	1	
E-18-20	7	HZY3-16026-000	JOINT SET	1	1	
E-18-20	8	HZY6-16036-003	PUMP UNIT, FUEL(B)	1	1	
E-18-20	9	HZY9-16042-013	HOLDER	1	1	
E-18-20	10	HZY9-16061-003	COVER, WATER JACKET	1	1	
E-18-20	11	HZY9-16071-003	O-RING	1	1	
E-18-20	12	HZY3-16072-000	O-RING	1	1	
E-18-20	13	HZY9-16072-003	PACKING	1	1	
E-18-20	14	HZY3-16073-000	O-RING	1	1	
E-18-20	15	HZY9-16073-003	O-RING	1	1	
E-18-20	16	HZY3-16077-000	O-RING	2	2	
E-18-20	17	HZW5-16081-010	SCREW-WASHER	9	9	
E-18-20	18	HZY9-16081-003	SCREW-WASHER	5	5	
E-18-20	19	HZY3-16082-000	SCREW, PAN	2	2	
E-18-20	20	HZY9-16082-003	SCREW-WASHER	3	3	
E-18-20	21	HZY3-16083-000	SCREW, WASHER	1	1	
E-18-20	22	HZY3-16087-000	WASHER, PLAIN	1	1	
E-18-20	23	HGHB-16163-610	CLIP, TUBE	2	2	
E-18-20	24	HZY3-16193-A00	CLAMP, CHECK VALVE	1	1	
E-18-20	25	HZY9-16701-003	CASE, PUMP	1	1	
E-18-20	26	HZY9-16708-003	COVER, PUMP(B)	1	1	
E-18-20	27	HZY9-16715-013	COVER, PUMP(A)	1	1	
E-18-20	28	HZY6-16718-013	INSULATOR COMP.	1	1	
E-18-20	29	HZY9-16721-003	INSULATOR	1	1	

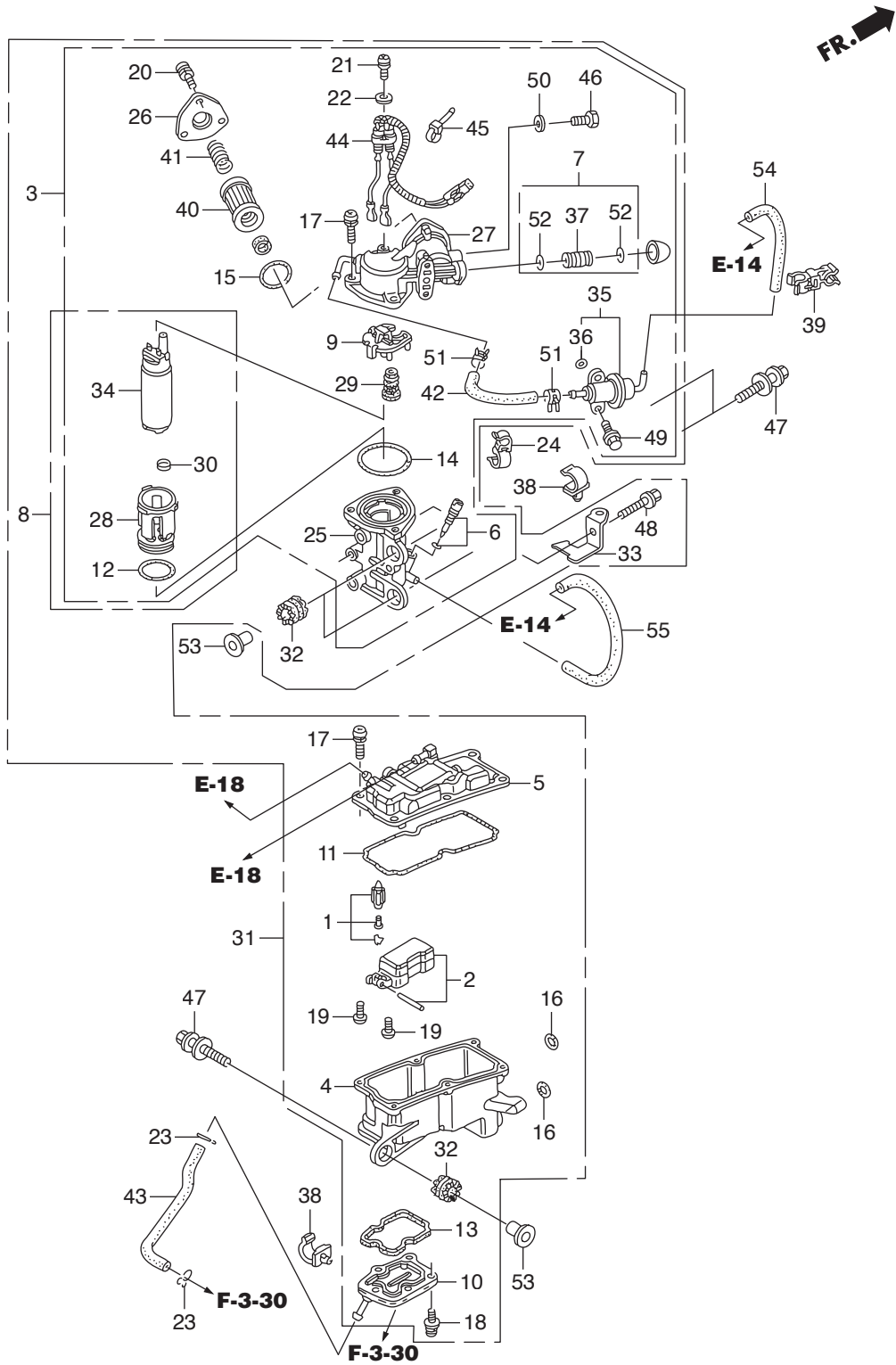

Ref.No.	Part No.	Description	Q' ty		Remarks	
			BET75A	BET90A		
E-18-20	30	HZY6-16723-003	RING	1	1	
E-18-20	31	HZY9-16730-063	SEPARATOR ASSY., VAPOR	1	1	
E-18-20	32	HZY9-16733-000	GROMMET, VAPOR SEPARATOR	3	3	
E-18-20	33	HZY9-16734-010	STAY, FUEL TUBE	1	1	
E-18-20	34	HZW5-16735-003	PUMP UNIT, FUEL	1	1	
E-18-20	35	HZY9-16740-003	REGULATOR ASSY., PRESSURE	1	1	
E-18-20	36	HPG7-16741-005	O-RING, PRESSURE REGULATOR	1	1	
E-18-20	37	HZY3-16752-000	JOINT, FUEL PIPE	1	1	
E-18-20	38	HZY9-16896-003	CLAMP B, FUEL TUBE	2	2	
E-18-20	39	HZY9-16898-003	CLAMP D, FUEL TUBE	1	1	
E-18-20	40	HZY3-16911-010	SCREEN COMP., FUEL STRAINER	1	1	
E-18-20	41	HZY9-16913-003	SPRING, COMPRESSION	1	1	
E-18-20	42	HZY9-17723-F00	HOSE, PRESSURE REGULATOR	1	1	RETURN
E-18-20	43	HZY9-19255-000	TUBE A, WATER	1	1	
E-18-20	44	HZY9-32166-013	HARNESS COMP.	1	1	
E-18-20	45	HZW5-32168-003	BAND	1	1	
E-18-20	46	HPP4-90009-E01	BOLT, SEALING, 6MM	1	1	
E-18-20	47	HZW1-90014-000	BOLT-WASHER, 8X35	3	3	
E-18-20	48	HZW9-90016-000	BOLT, FLANGE, 6X25	3	3	
E-18-20	49	HZY3-90021-000	BOLT, FLANGE, 6X14	2	2	
E-18-20	50	HPD6-90430-003	WASHER, SEALING, 6MM	1	1	
E-18-20	51	HZW5-90601-030	CLAMP, TUBE(D10.7)	2	2	
E-18-20	52	HMJ0-91301-003	O-RING, 7.8X1.9(ARAI)	2	2	
E-18-20	53	HZW1-91554-000	COLLAR, 8.5X14.5	3	3	
E-18-20	54	HCO-95001-35120-40	TUBE, FUEL,3.5 × 120	1	1	(HC-95001-35001-60M)
E-18-20	55	HCO-95003-11024-31	TUBE, VINYL, 5X9X240	1	1	(HC-95003-11001-60M)

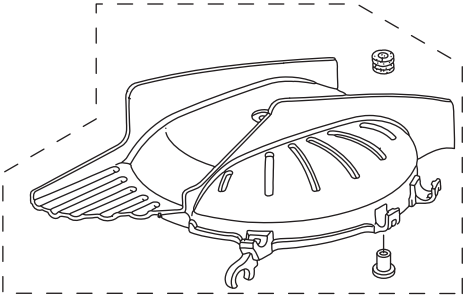

F-7-30

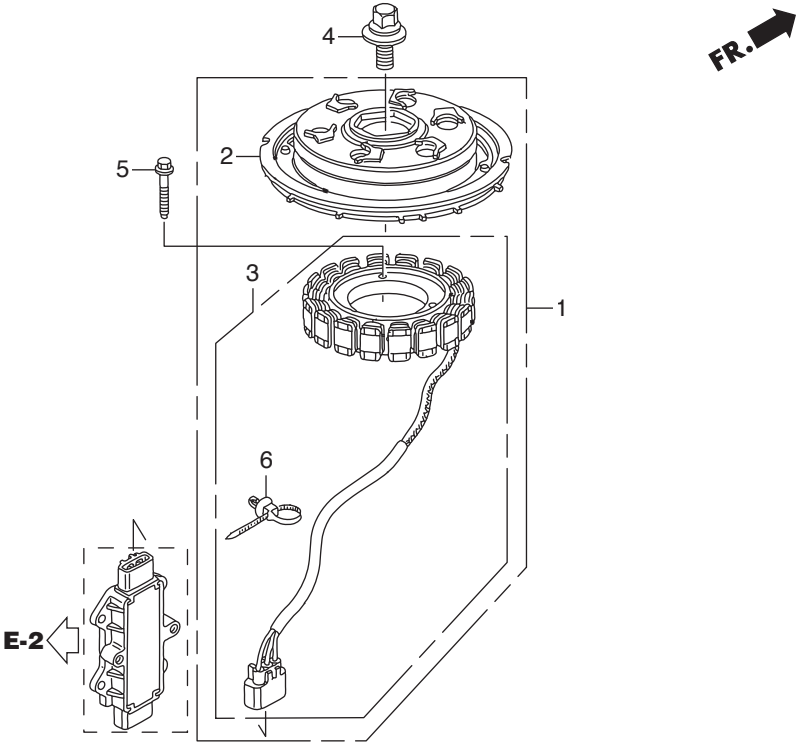

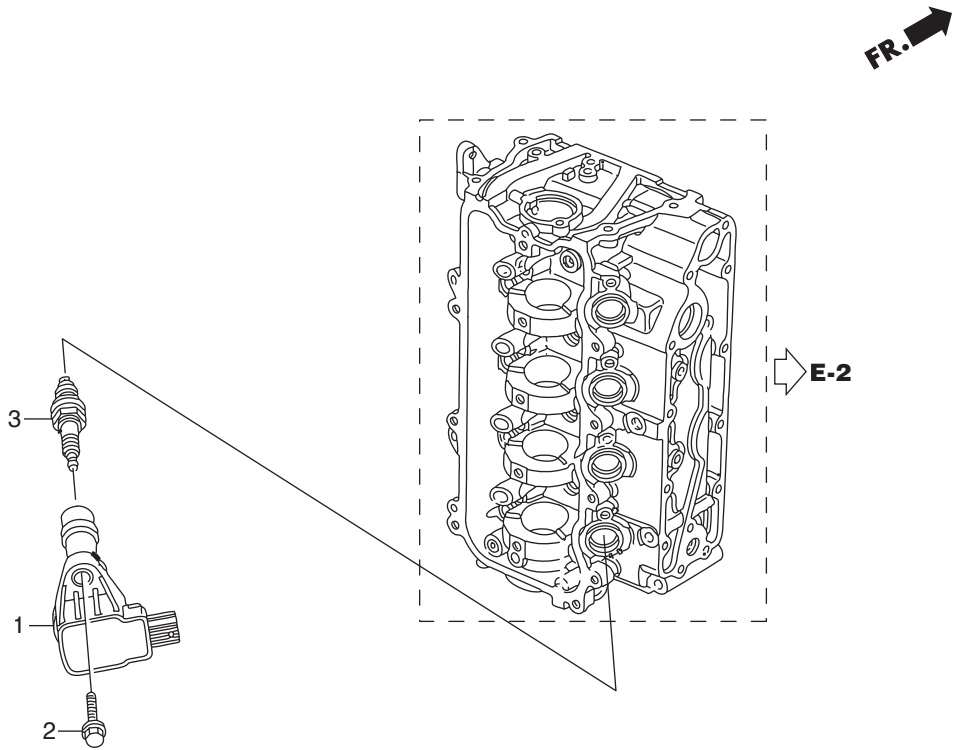

FR. 

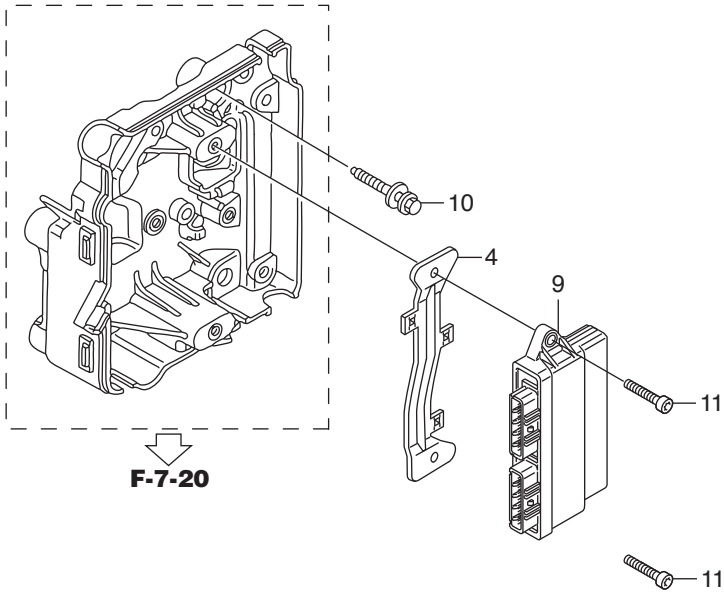

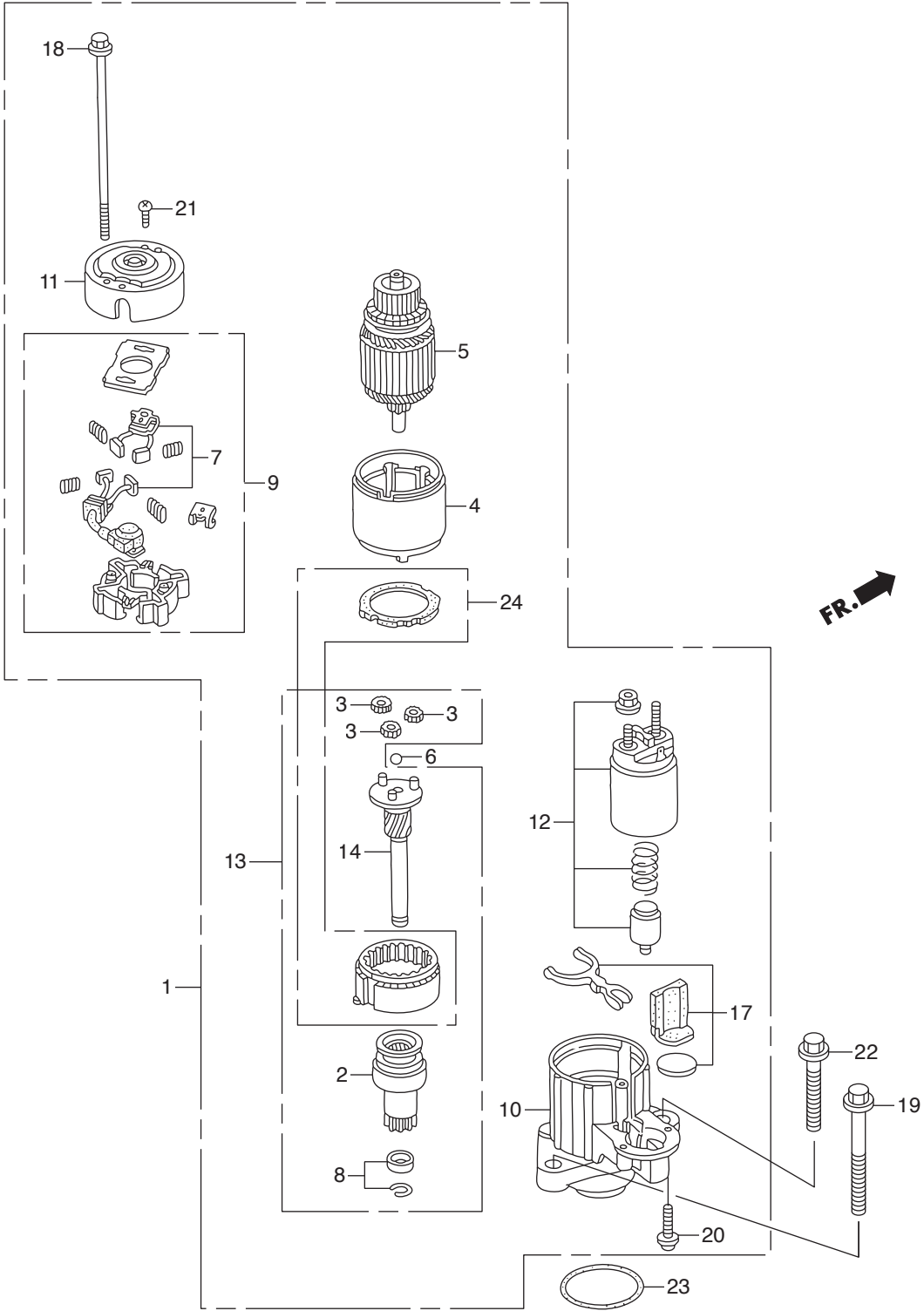

Ref.No.	Part No.	Description	Q' ty		Remarks	
			BET75A	BET90A		
E-21	1	HZY9-31200-H01	MOTOR ASSY., STARTER	1	1	
E-21	2	HZY9-31207-H01	CLUTCH COMP., OVERRUNNING	1	1	
E-21	3	HPY3-31215-004	GEAR ASSY., PLANETARY	3	3	
E-21	4	HZY9-31216-003	YOKE COMP.	1	1	
E-21	5	HZW1-31217-004	ROTOR COMP.	1	1	
E-21	6	HPY3-31218-004	BALL, STEEL	1	1	
E-21	7	HZY9-31227-H01	BRUSH SET	1	1	
E-21	8	HZY9-31229-H01	STOPPER SET, SLEEVE	1	1	
E-21	9	HZY9-31231-H01	HOLDER COMP., BRUSH	1	1	
E-21	10	HZY6-31235-003	BRACKET, FR.	1	1	
E-21	11	HZY6-31236-003	BRACKET, RR.	1	1	
E-21	12	HZY9-31240-003	SWITCH ASSY., MAGNET	1	1	
E-21	13	HZY9-31242-H01	SHAFT ASSY., CLUTCH	1	1	
E-21	14	HZY9-31246-H01	SHAFT ASSY., GEAR	1	1	
E-21	17	HZW1-31250-004	LEVER SET	1	1	
E-21	18	HZW1-31261-004	BOLT A, THROUGH	2	2	
E-21	19	HZY6-90013-000	BOLT, FLANGE, 10X75	1	1	
E-21	20	HZY9-31226-H01	SCREW, PAN, 6X22	2	2	
E-21	21	HZW1-90107-004	SCREW, PAN, 5X8	2	2	
E-21	22	HZW4-90159-000	BOLT, FLANGE, 10X35	1	1	
E-21	23	HZY3-91303-000	O-RING, 59.4X3.1	1	1	
E-21	24	HZY9-31251-H01	GEAR ASSY., INTERNAL	1	1	

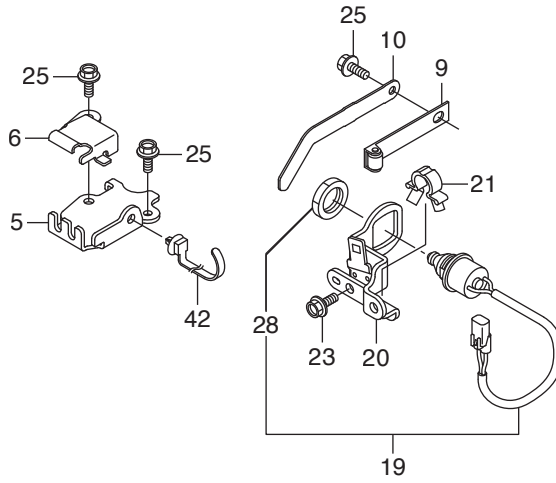

FR.

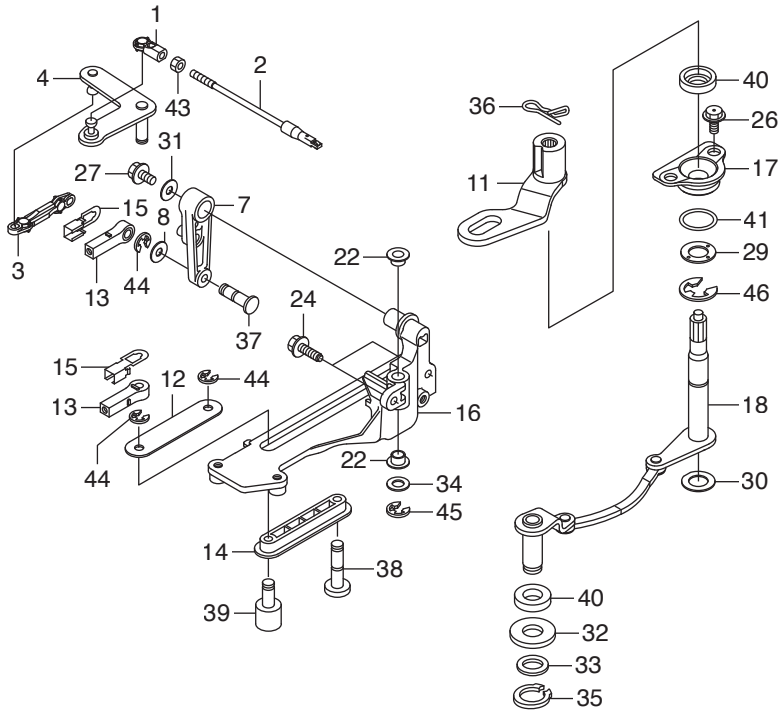

Ref.No.	Part No.	Description	Q' ty		Remarks	
			BET75A	BET90A		
F-2	1	HZV5-17838-000	LINKAGE, PIVOT	1	1	
F-2	2	HZY9-17840-000	ROD COMP., THROTTLE	1	1	
F-2	3	HZY6-17845-000	LINK, THROTTLE	1	1	
F-2	4	HZY9-17860-000	PLATE COMP., THROTTLE	1	1	
F-2	5	HZY9-17877-000	PLATE, REMOTE CONTROL CABLE	1	1	
F-2	6	HZY9-17878-000	COVER, REMOTE CONTROL CABLE	1	1	
F-2	7	HZY6-17931-000	ARM, THROTTLE	1	1	
F-2	8	H921-17936-000	WASHER, PIVOT	1	1	
F-2	9	HZW1-24210-010	SPRING COMP., CLICK	1	1	
F-2	10	HZY9-24221-000	SPRING, CLICK ASSIST	1	1	
F-2	11	HZY9-24612-000	ARM, SHIFT	1	1	
F-2	12	HZY9-24614-000	PLATE, SHIFT PIVOT	1	1	
F-2	13	HZY3-24618-000	PIVOT, SHIFT	2	2	
F-2	14	HZY9-24618-000	PIVOT, SHIFT SLIDE	1	1	
F-2	15	HZY3-24619-000	PLATE, LOCK	2	2	
F-2	16	HZY9-24628-000	BRACKET, SHIFT LINK	1	1	
F-2	17	HZW1-24629-000	HOLDER, SEAL	1	1	
F-2	18	HZY9-24630-000	SHAFT COMP., SHIFT	1	1	
F-2	19	HZY9-35470-023	SWITCH ASSY., NEUTRAL	1	1	
F-2	20	HZY9-35475-010	BRACKET, NEUTRAL SWITCH	1	1	
F-2	21	HVM0-46391-003	CLIP, BRAKE PIPE(A)	1	1	
F-2	22	HZY3-63205-000	BUSH A. COVER LOCK	2	2	
F-2	23	HZW9-90011-000	BOLT, FLANGE, 6X14(CT200)	1	1	
F-2	24	HZV0-90017-C10	BOLT, FLANGE, 6X18(CT200)	2	2	
F-2	25	HZY3-90017-000	BOLT, FLANGE, 6X16	3	3	
F-2	26	HZW5-90023-000	BOLT, FLANGE, 6X11	2	2	
F-2	27	HZY3-90056-000	BOLT, FLANGE, 6X12	1	1	
F-2	28	HZV5-90302-003	NUT, HEX., 20MM	1	1	
F-2	29	HGET-90429-000	WASHER, SIDE, 14MM	1	1	

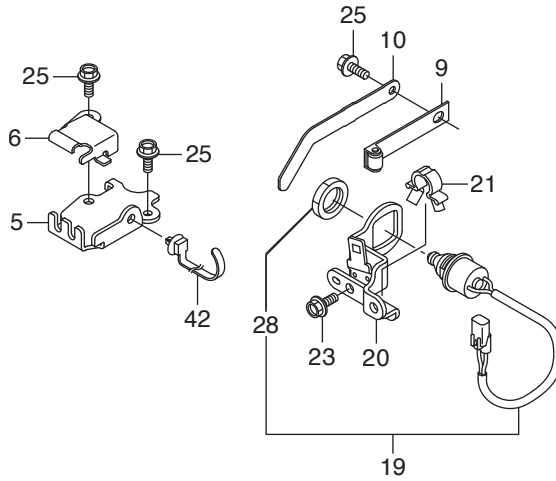

FR. ←

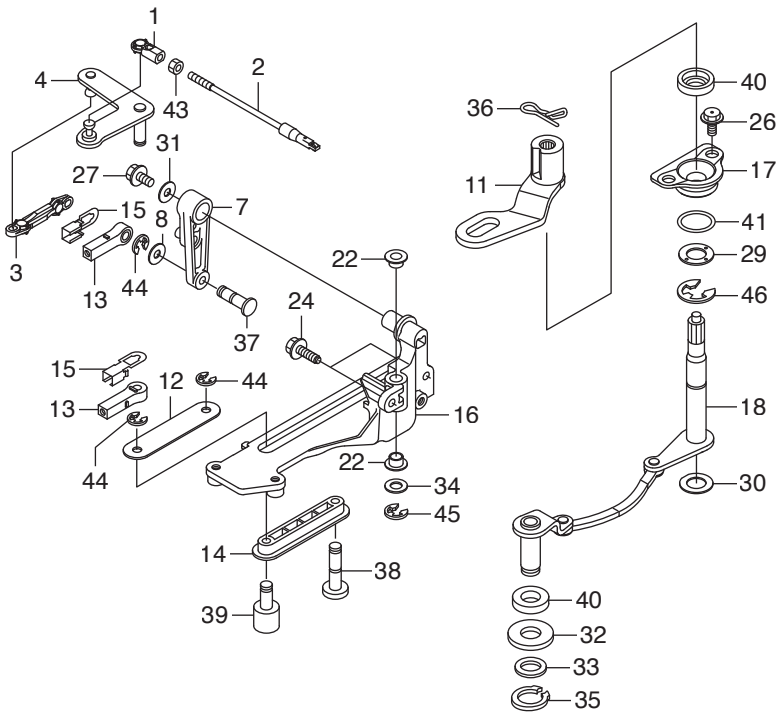

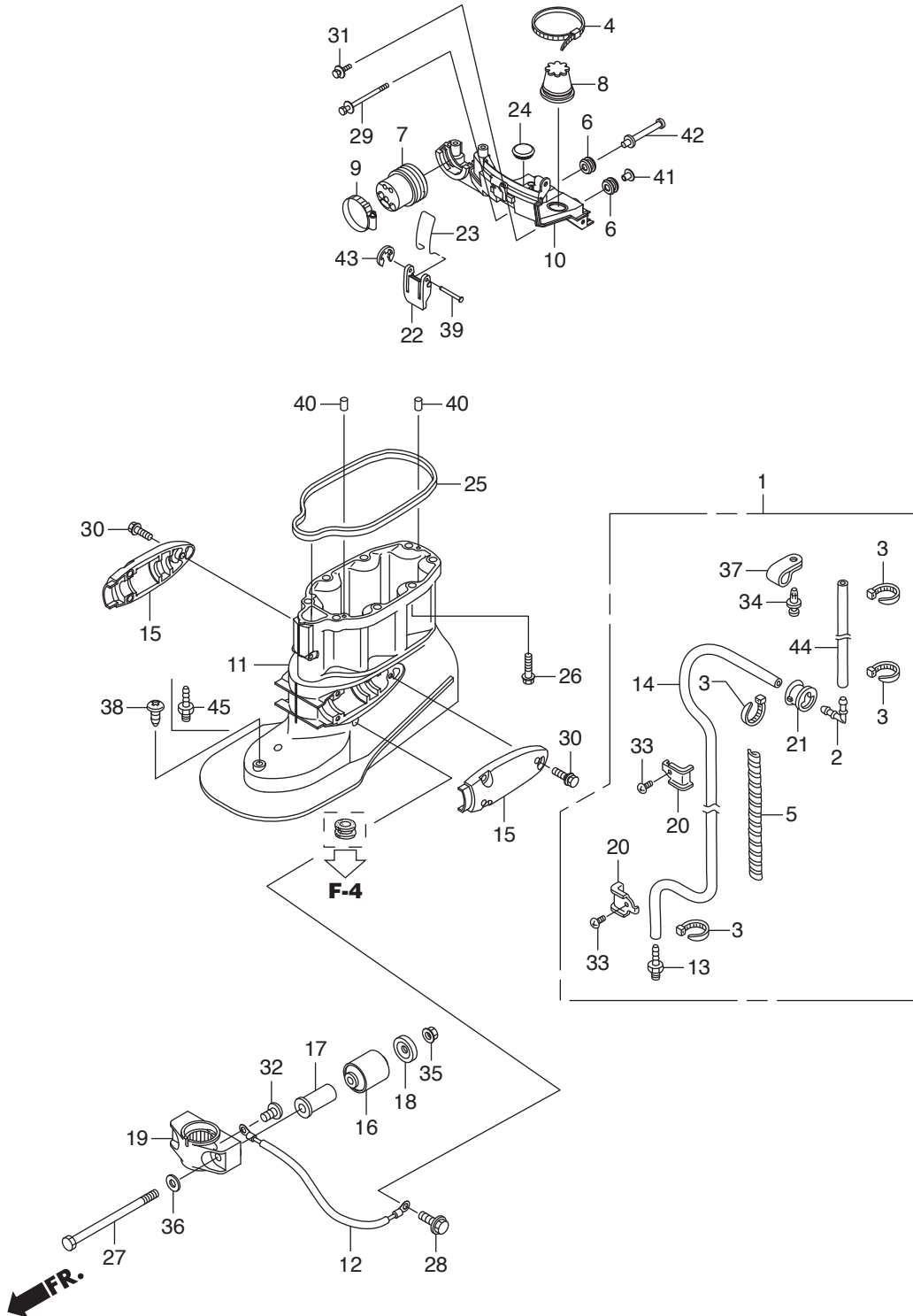

Ref.No.	Part No.	Description	Q' ty		Remarks	
			BET75A	BET90A		
F-3	1	HZY9-06411-010	TUBE KIT, SPEED SENSOR	1	1	
F-3	2	HGE1-17357-670	JOINT A, BREATHER	1	1	
F-3	3	HKM3-32161-003	BAND, WIRE	4	4	
F-3	4	HMG9-35701-950	BAND(BLACK 3.5X140)	1	1	
F-3	5	HZY6-36104-003	TUBE, SPIRAL	1	1	
F-3	6	HZV5-40102-000	GROMMET, UNDER CASE	3	3	
F-3	7	HZY9-40105-000	GROMMET, REMOTE CONTROL CABLE	1	1	
F-3	8	HZW1-40107-700	GROMMET, UNDER CASE(C)	1	1	
F-3	9	HZY3-40119-003	BAND, UNDER CASE GROMMET	1	1	
F-3	10	HZY9-40154-000ZC	BRACKET, FR. UNDER COVER	1	1	*T107* BAY BLUE
F-3	11	HZY9-40201-020ZC	CASE, EXTENSION	1	1	*T107* BAY BLUE
F-3	12	HZY6-40219-023	WIRE, LEAD(1.5X137MM)	1	1	
F-3	13	HZV5-41172-000	NIPPLE, SENSOR	1	1	
F-3	14	HZY9-41173-000	TUBE, SPEED SENSOR	1	1	
F-3	15	HZY9-50111-000ZC	HOUSING, LOWER MOUNTING	2	2	*T107* BAY BLUE
F-3	16	HZZ0-50155-000	MOUNT COMP., LOWER RUBBER	2	2	
F-3	17	HZY9-50156-000	COLLAR, LOWER MOUNTING	2	2	
F-3	18	HZY9-50157-000	STOPPER, LOWER MOUNT	2	2	
F-3	19	HZW1-50161-020ZC	HOUSING, LOWER CENTER MOUNTING	1	1	*T107* BAY BLUE
F-3	20	HZY6-50209-000	PLATE, SPEED SENSOR TUBE	2	2	
F-3	21	HZY6-56118-000	BUSH, MOTOR CODE	1	1	
F-3	22	HZY9-63232-010	LEVER, FASTENER	1	1	
F-3	23	HZY9-63237-000	WIRE, FASTENER	1	1	
F-3	24	HZC0-63515-700	CAP, L. SIDE COVER	1	1	
F-3	25	HZY9-63719-000	SEAL B, COVER UNDER	1	1	
F-3	26	HZY6-90002-000	BOLT, FLANGE, 10X40	8	8	
F-3	27	HZY9-90102-000	BOLT, HEX., 12X186	2	2	
F-3	28	HZW9-90103-010	BOLT, FLANGE, 6X12	1	1	
F-3	29	HZY9-90104-000	BOLT-WASHER, 6X95	1	1	

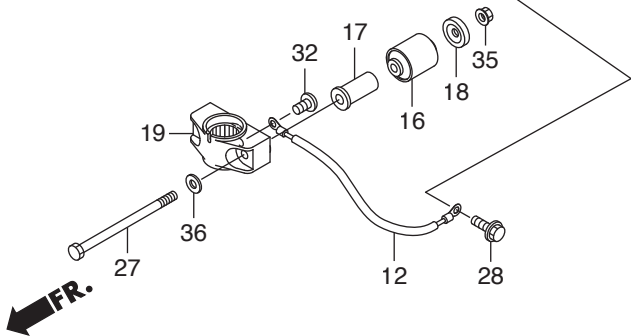
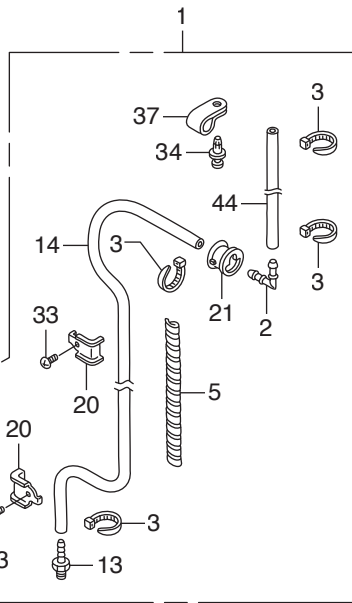
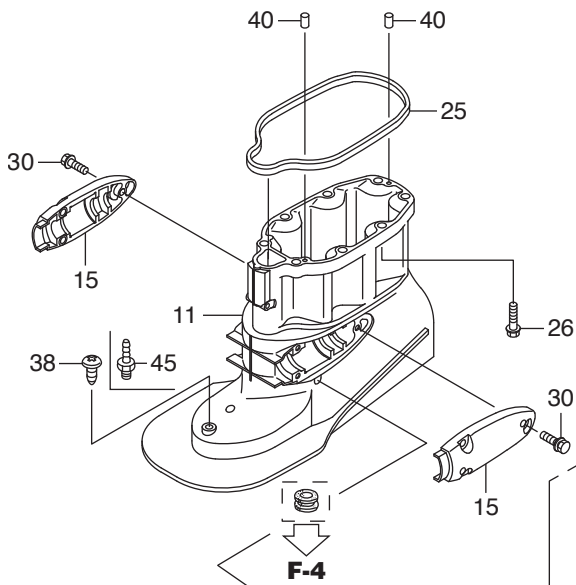
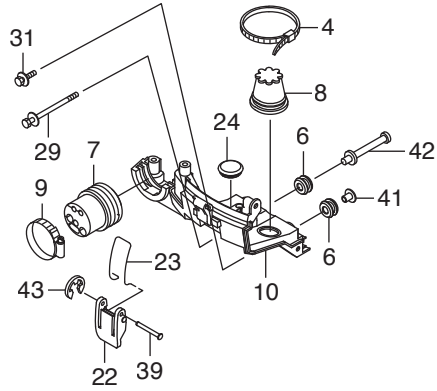

Ref.No.	Part No.	Description	Q' ty		Remarks	
			BET75A	BET90A		
F-3-10	1	HZW1-19286-B00	PLATE, RUBBER SETTING	1	1	
F-3-10	2	HZY9-40202-H50ZB	SEPARATOR, EXTENSION(XL)		1	*T107* BAY BLUE XRTA
F-3-10	3	HZW1-40210-710	BUSH COMP., VERTICAL SHAFT		1	XRTA
F-3-10	4	HZY9-41101-H00ZB	CASE, GEAR	1	1	*T107* BAY BLUE
F-3-10	5	HZW1-41102-B00	GROMMET, GEAR CASE	1	1	
F-3-10	6	HZZ0-41102-000	COVER B, GEAR CASE	1	1	
F-3-10	7	HZZ0-41103-000	GROMMET, GEAR CASE	1	1	
F-3-10	8	HZZ0-41104-010	SCREEN, R. WATER	1	1	
F-3-10	9	HZZ0-41105-010	SCREEN, L. WATER	1	1	
F-3-10	10	HZZ0-41107-000ZD	TAB, TRIM	1	1	*T107* BAY BLUE
F-3-10	11	HZW1-41109-B00	METAL COMP., ANODE	2	2	
F-3-10	12	HZW9-90101-003	BOLT, OIL CHECK	1	1	
F-3-10	13	HZZ0-90101-000	SCREW, FLAT, 5X55	1	1	
F-3-10	14	HZW1-90104-900	BOLT, HEX., 10X80	1	1	LRTA
F-3-10	15	HZV5-90115-000	BOLT, HEX., 8X25	1	1	
F-3-10	16	HZY3-90120-000	BOLT, DRAIN PLUG	1	1	
F-3-10	17	HZY6-90123-000	BOLT-WASHER, 10X40	4	4	LRTA
F-3-10	18	HZW1-90124-910	BOLT, STUD(10X202)		1	XRTA
F-3-10	19	HZW1-90125-910	BOLT, STUD(10X164)		4	XRTA
F-3-10	20	HZY3-90133-000	BOLT, SOCKET, 6X16	1	1	
F-3-10	21	HZY1-90205-000	NUT, SELF-LOCK, 6MM	1	1	
F-3-10	22	HHW1-90225-670	BOLT, FLANGE, 6X35	1	1	
F-3-10	23	HZV4-90302-000	NUT, SELF-LOCK, 5MM	1	1	
F-3-10	24	HZV5-90306-003	NUT, SELF-LOCK, 10MM		5	XRTA
F-3-10	25	HZW1-90501-710	WASHER, 26MM		1	XRTA
F-3-10	26	HZV4-90507-000	WASHER, PLAIN, 8MM	1	1	
F-3-10	27	HZV5-90563-000	WASHER, PLAIN, 10MM	1	1	LRTA
F-3-10	27	HZV5-90563-000	WASHER, PLAIN, 10MM		5	XRTA
F-3-10	28	HZW1-90651-710	CIRCLIP, INTERNAL, 40		1	XRTA

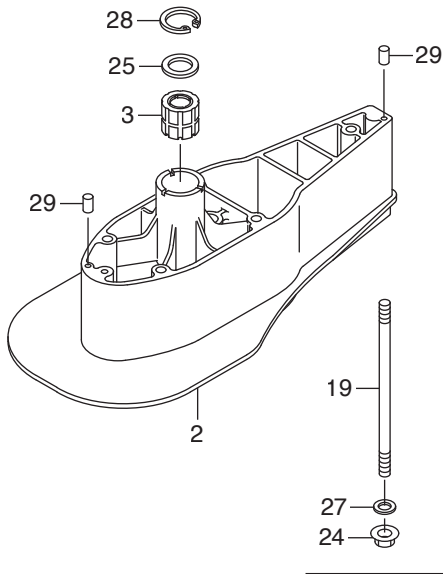

FR.

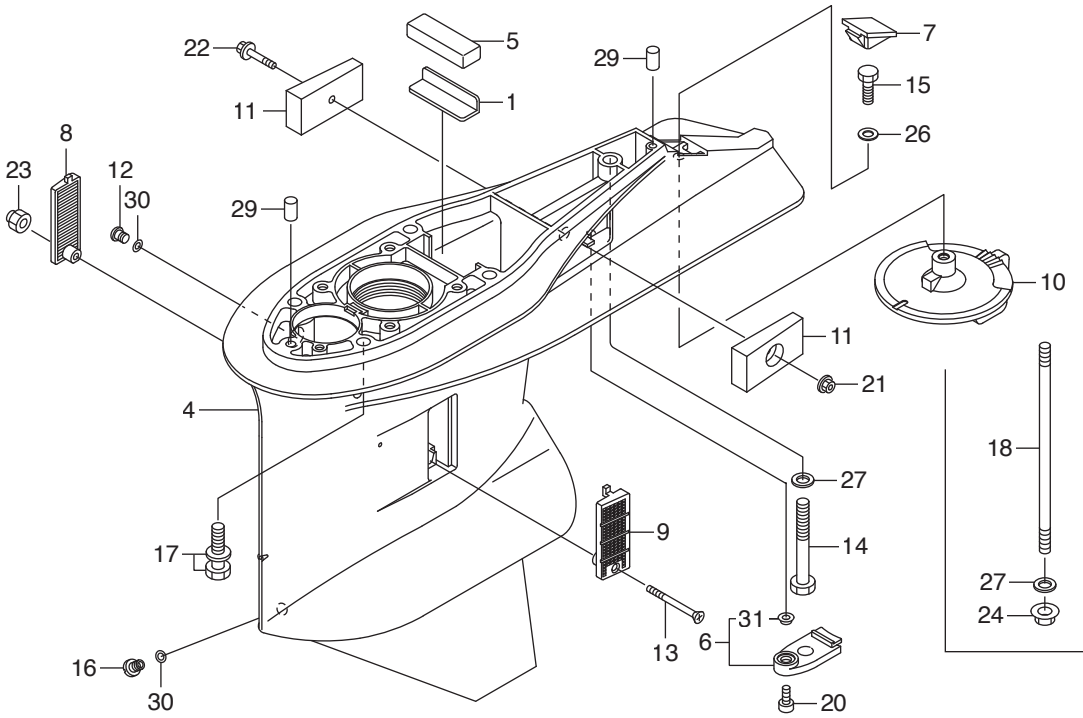

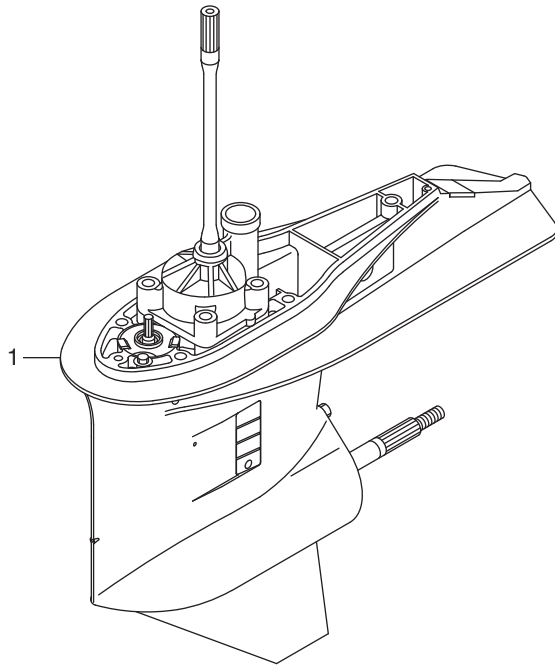

←FR.

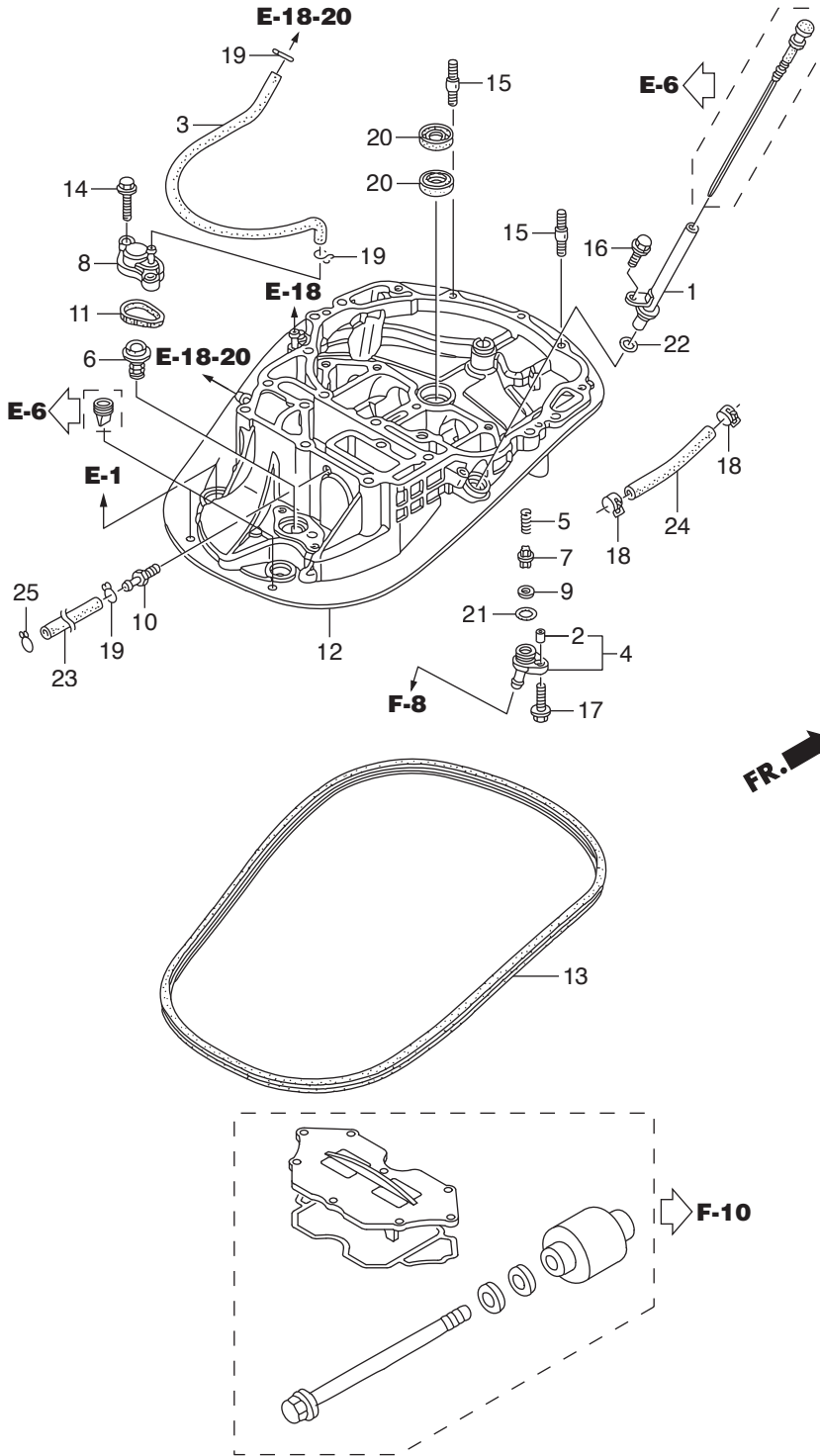

Ref.No.	Part No.	Description	Q' ty		Remarks	
			BET75A	BET90A		
F-3-30	1	HZY9-15665-000	PIPE COMP., OIL LEVEL	1	1	
F-3-30	2	HZV5-17202-310	COLLAR, DISTANCE, 6.5X11X7.5	1	1	
F-3-30	3	HZY9-19256-000	TUBE B, WATER	1	1	
F-3-30	4	HZY9-19277-000	COVER, FLUSH VALVE	1	1	
F-3-30	5	HZW9-19279-000	SPRING, FLUSH VALVE	1	1	
F-3-30	6	HZY6-19290-003	VALVE ASSY., RELIEF	1	1	
F-3-30	7	HZW9-19291-000	VALVE, FLASH	1	1	
F-3-30	8	HZY9-19295-000	COVER, RELIEF VALVE	1	1	
F-3-30	9	HZW9-19297-000	PACKING, FLASH VALVE	1	1	
F-3-30	10	HZW4-19312-H00	JOINT, WATER TUBE	1	1	
F-3-30	11	HZW9-19317-000	O-RING, THERMOSTAT COVER	1	1	
F-3-30	12	HZY9-23170-010ZA	CASE COMP., MOUNT	1	1	*NH8* DARK GRAY
F-3-30	13	HZY9-63718-000	SEAL A, COVER UNDER	1	1	
F-3-30	14	HZY3-90030-000	BOLT, FLANGE, 6X22	2	2	
F-3-30	15	HZY3-90043-000	BOLT, STUD, 8X28	2	2	
F-3-30	16	HZY3-90056-000	BOLT, FLANGE, 6X12	1	1	
F-3-30	17	HZW9-90105-000	BOLT, FLANGE, 6X20	1	1	
F-3-30	18	HZY3-90601-030	CLAMP, TUBE(D10.5)	2	2	
F-3-30	19	HZV4-90603-000	CLIP, TUBE(B10)	3	3	
F-3-30	20	HZW5-91202-003	SEAL, WATER, 22X35X7	2	2	
F-3-30	21	H800-91303-000	O-RING, 16MM	1	1	
F-3-30	22	HPJ7-91309-010	O-RING, 11.5X3.5	1	1	
F-3-30	23	HZY9-91402-000	TUBE, WATER CHECK	1	1	
F-3-30	24	HCO-95005-70110-30	TUBE, 7X110	1	1	(HC-95005-70001-30M)
F-3-30	25	HGHB-16163-600	CLIP, TUBE	1	1	

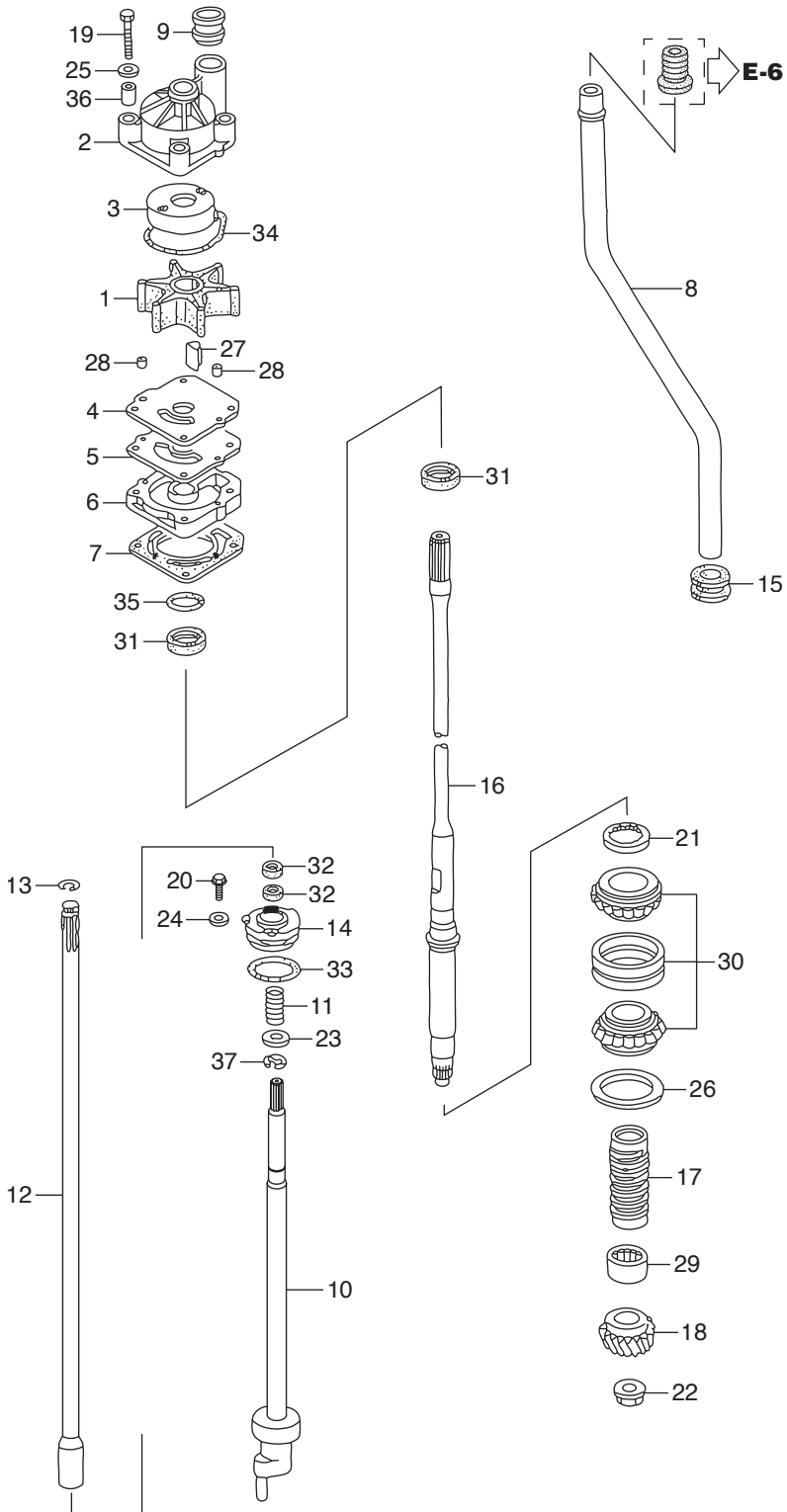

Ref.No.	Part No.	Description	Q' ty		Remarks	
			BET75A	BET90A		
F-4	1	HZY9-19210-H01	IMPELLER, PUMP	1	1	
F-4	2	HZY9-19221-H00	HOUSING, IMPELLER	1	1	
F-4	3	HZY9-19223-H00	LINER, PUMP	1	1	
F-4	4	HZY9-19231-H00	COVER, IMPELLER	1	1	
F-4	5	HZW1-19234-B00	GASKET B, IMPELLER	1	1	
F-4	6	HZZ0-19241-000	HOUSING, WATER PUMP	1	1	
F-4	7	HZW1-19242-B00	GASKET, WATER PUMP	1	1	
F-4	8	HZY9-19251-000	TUBE, WATER(L)	1	1	LRTA
F-4	8	HZY9-19251-610	TUBE, WATER(XL)		1	XRTA
F-4	9	HZW1-19253-B01	RING, WATER TUBE SEAL	1	1	
F-4	10	HZZ0-24310-000	ROD COMP., SHIFT(L)	1	1	
F-4	11	HZY3-24318-000	SPRING, SHIFT ROD	1	1	
F-4	12	HZW1-24320-B00	ROD A COMP., SHIFT(L)	1	1	LRTA
F-4	12	HZY9-24320-610	ROD A COMP., SHIFT(XL)		1	XRTA
F-4	13	HZW1-24327-000	RING, STOPPER	1	1	
F-4	14	HZY9-24343-H00	HOLDER, SHIFT ROD	1	1	
F-4	15	HZW1-40204-000	GROMMET, EXTENSION CASE	1	1	
F-4	16	HZW1-41112-B03	SHAFT, VERTICAL(L)	1	1	LRTA
F-4	16	HZW1-41112-B33	SHAFT, VERTICAL(UL)		1	XRTA
F-4	17	HZW1-41116-B00	SLINGER, OIL	1	1	
F-4	18	HZW1-41131-B01	GEAR, PINION(12T)	1	1	
F-4	19	HZV5-90010-000	BOLT, HEX., 8X55	4	4	
F-4	20	HZW9-90102-000	BOLT, FLANGE, 6X12	1	1	
F-4	21	HZW1-90242-000	NUT, LOCK, 64MM	1	1	
F-4	22	HZW1-90303-B03	NUT, HEX., 16MM	1	1	
F-4	23	H723-90472-000	WASHER, PLAIN, 12MM	1	1	
F-4	24	HZV4-90511-000	WASHER, PLAIN, 6MM	1	1	
F-4	25	H921-90514-000	WASHER, 8MM	4	4	
F-4	26	HZW1-90518-B00	SHIM A, GEAR(0.10)	1	1	

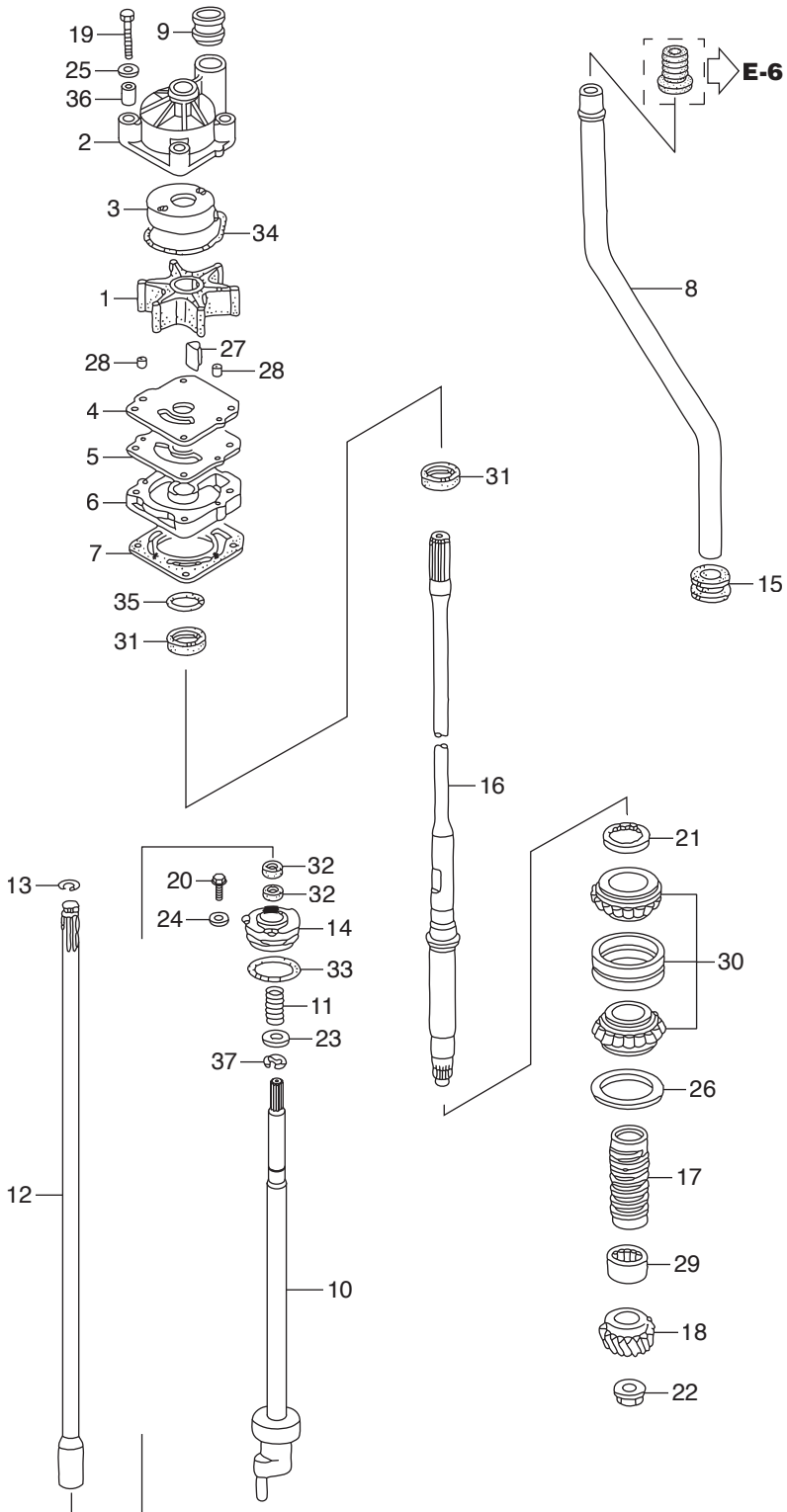

FR.

Ref.No.	Part No.	Description	Q' ty		Remarks	
			BET75A	BET90A		
F-5	1	HZZ0-24101-010	SHIFTER, CLUTCH	1	1	
F-5	2	HZW1-24102-B00	PIN, SHIFTER, 8X47	1	1	
F-5	3	HZW1-24103-B00	RING, CROSS PIN	1	1	
F-5	4	HZZ0-24113-000	SLIDER COMP., SHIFT	1	1	
F-5	5	HZZ0-24122-000	SLIDER, SHIFT	1	1	
F-5	6	HZZ0-24123-000	SPRING, SHIFT	2	2	
F-5	7	HZZ0-24124-000	PLATE, SHIFT	1	1	
F-5	8	HZZ0-41140-010	GEAR COMP., FR. BEVEL	1	1	
F-5	9	HZY9-41151-H00	GEAR, RR. BEVEL	1	1	
F-5	10	HZZ0-41160-010	SHAFT ASSY., PROPELLER	1	1	
F-5	11	HZZ0-41161-000	SHAFT, PROPELLER	1	1	
F-5	12	HZW1-41201-B02ZD	HOLDER, PROPELLER SHAFT	1	1	*T107* BAY BLUE
F-5	13	HZY6-90123-000	BOLT-WASHER, 10X40	2	2	
F-5	14	HZW1-90301-B00	NUT, CASTLE, 18MM	1	1	
F-5	15	HZW1-90506-B00	WASHER, PROPELLER THRUST	1	1	
F-5	16	HZW1-90508-B00	WASHER, PLAIN, 18.5MM	1	1	
F-5	17	HZW1-90528-B00	SHIM A, BEVEL(FR.)(0.10)	1	1	
F-5	17	HZW1-90529-B00	SHIM B, BEVEL(FR.)(0.15)	1	1	
F-5	17	HZW1-90530-B00	SHIM C, BEVEL(FR.)(0.30)	1	1	
F-5	17	HZW1-90531-B00	SHIM D, BEVEL(FR.)(0.50)	1	1	
F-5	18	HZW1-90758-B00	PIN, SPLIT, 4.0	1	1	
F-5	19	HMY5-91005-601	BEARING, NEEDLE, 30X37X26	1	1	
F-5	20	HZW1-91051-B02	BEARING, TAPERED ROLLER	1	1	(50X82X21.5)
F-5	21	HZW5-91054-003	BEARING, BALL(28X38X3)	2	2	
F-5	22	HZW1-91101-003	ROLLER, 3X12.8	1	1	
F-5	23	HZZ3-91252-003	SEAL, WATER, 30X45X7	2	2	
F-5	24	HZW1-91351-B02	O-RING, 94X4.1	1	1	
F-5	25	HCO-94510-14000	CIRCLIP, EXTERNAL, 14MM	1	1	
F-5	26	HCO-96100-62080-00	BEARING, RADIAL BALL, 6208	1	1	

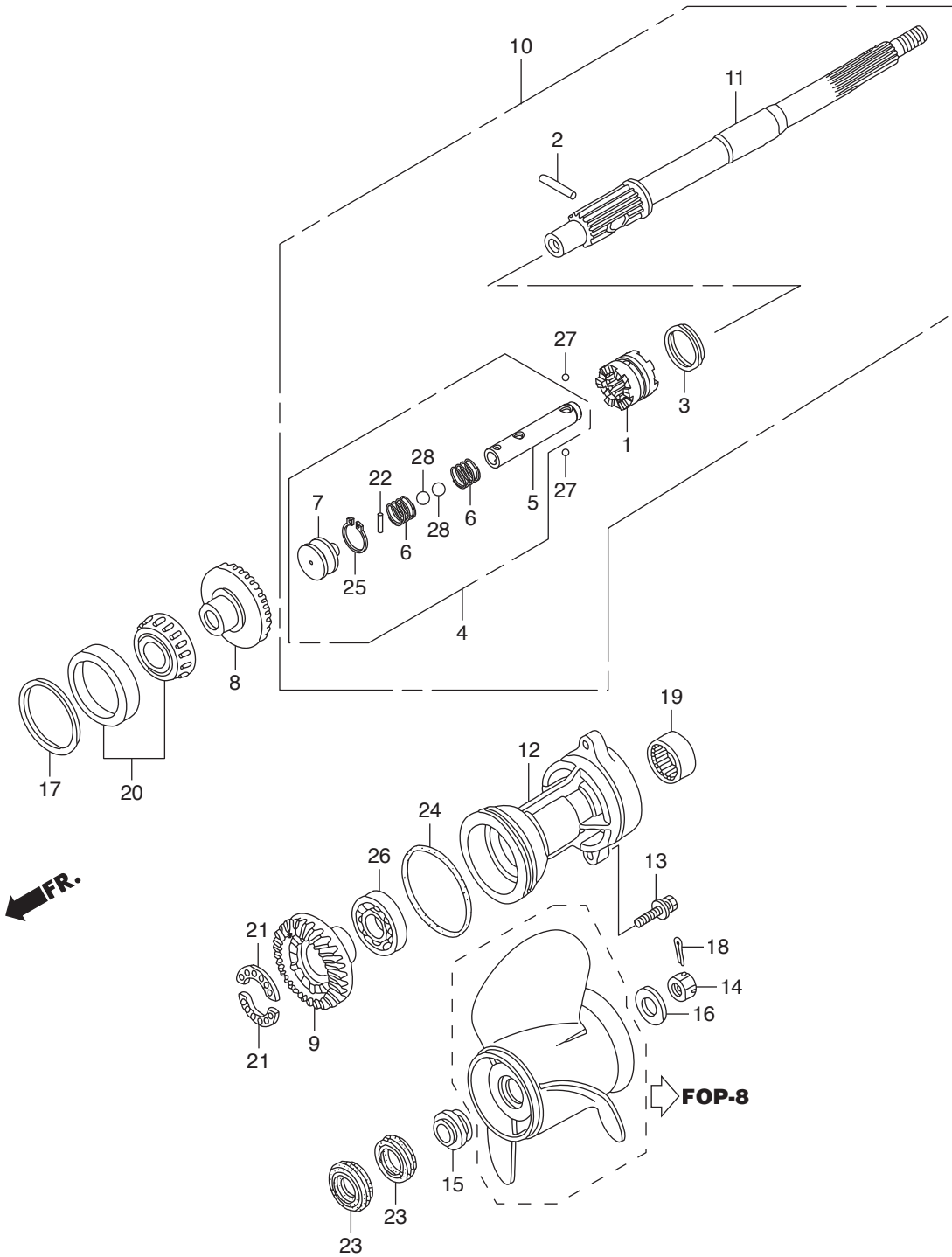

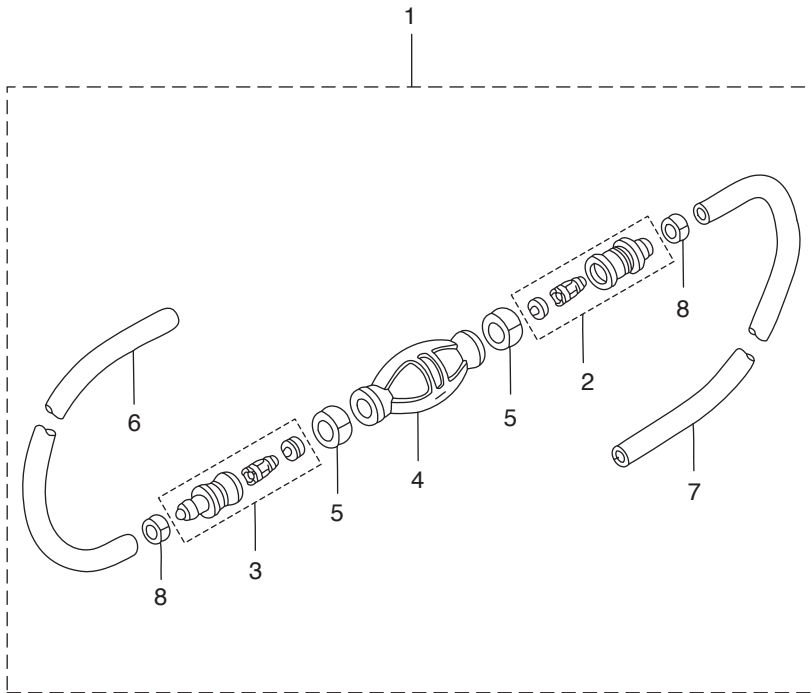

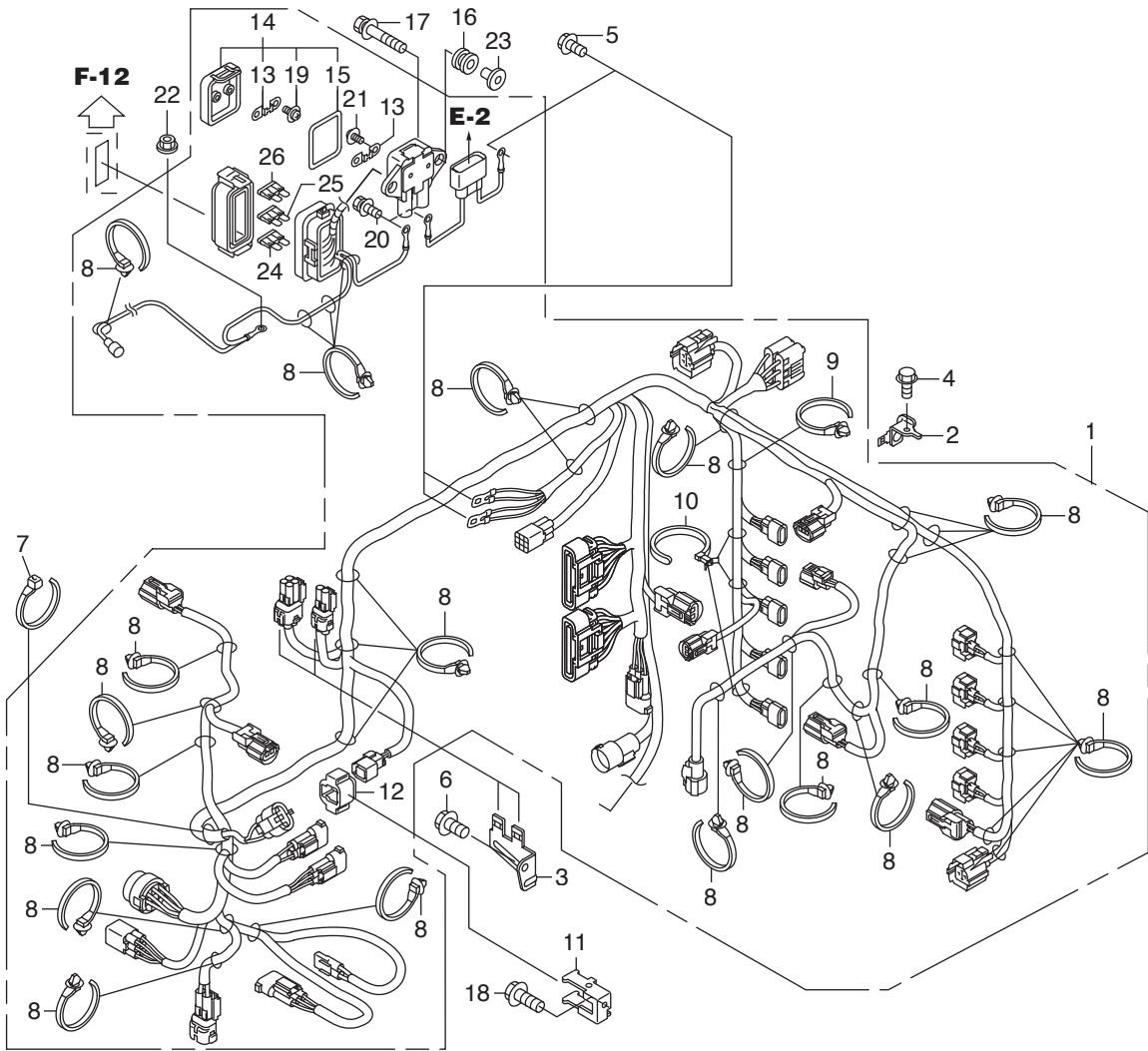

FR. ←

Ref.No.	Part No.	Description	Q' ty		Remarks	
			BET75A	BET90A		
F-7	1	HZY9-32100-H00	HARNESS ASSY., MAIN WIRE	1		
F-7	1	HZZ0-32100-H00	HARNESS ASSY., MAIN WIRE		1	
F-7	2	HZY9-32101-000	BRACKET A, COUPLER	1	1	
F-7	3	HZY9-32103-000	BRACKET C, COUPLER	1	1	
F-7	4	HZW9-90011-000	BOLT, FLANGE, 6X14(CT200)	1	1	
F-7	5	HZW9-90013-000	BOLT, FLANGE, 6X12	3	3	
F-7	6	HZW9-90014-000	BOLT, FLANGE, 6X10	1	1	
F-7	7	HZY9-90652-003	BAND, WIRE HARNESS	1	1	
F-7	8	HS0A-91541-003	CLIP, HARNESS BAND(BLACK)	31	31	(145MM)
F-7	9	HSW5-91551-003	CLIP, HARNESS BAND(BROWN)	1	1	(151MM)
F-7	10	HSJ6-91558-003	STRAP, HARNESS(30)(BLACK)	3	3	(107.5MM)
F-7	11	HZY9-32104-H00	BRACKET, COUPLER	1	1	
F-7	12	HZZ3-32127-000	SUSPENSION, COUPLER	1	1	
F-7	13	HZY9-38201-003	FUSE(70A)	2	2	
F-7	14	HZY9-38216-003	COVER ASSY., FUSE(70A)	1	1	
F-7	15	HZY9-38233-000	PACKING, FUSE BOX COVER	1	1	
F-7	16	HZW1-38551-000	GROMMET, RELAY	2	2	
F-7	17	HZW2-90003-000	BOLT-WASHER, 6X27(CT200)	2	2	
F-7	18	HZW9-90011-000	BOLT, FLANGE, 6X14(CT200)	1	1	
F-7	19	HZW5-90105-003	SCREW-WASHER, 3X7	2	2	
F-7	20	HZW5-90106-000	BOLT-WASHER, 5X9	2	2	
F-7	21	HSB2-90153-003	SCREW-WASHER, 5X10	2	2	
F-7	22	HZW1-90203-000	NUT-WASHER, 8MM	1	1	
F-7	23	HZV5-91553-010	COLLAR, C.D.I. UNIT CASE	2	2	
F-7	24	HCO-98200-41000	FUSE, MINI(10A)	4	4	
F-7	25	HCO-98200-41500	FUSE, MINI(15A)	3	3	
F-7	26	HCO-98200-43000	FUSE, MINI(30A)	2	2	

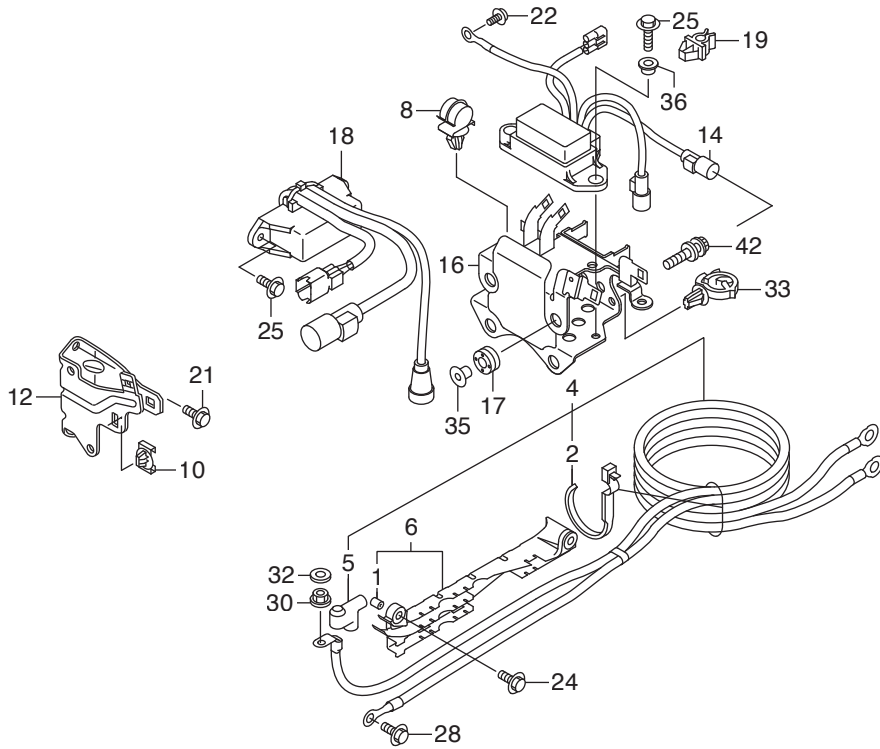

Ref.No.	Part No.	Description	Q' ty		Remarks	
			BET75A	BET90A		
F-7-10	1	HZV5-17202-310	COLLAR, DISTANCE, 6.5X11X7.5	2	2	
F-7-10	2	HHA0-32121-003	BAND, CORD	1	1	
F-7-10	4	HZY9-32410-000	CABLE ASSY., STARTER	1	1	
F-7-10	5	HZY3-32411-003	COVER, STARTER TERMINAL	1	1	
F-7-10	6	HZY9-32418-000	HOLDER COMP., STARTER CABLE	1	1	
F-7-10	8	HMJ6-32660-710	CLAMPER, CORD	1	1	
F-7-10	10	HZY3-38216-003	CLIP, COUPLER HOLDER(B)	1	1	
F-7-10	12	HZY9-38217-000	BRACKET, FUSE BOX	1	1	
F-7-10	14	HZY9-38550-003	RELAY ASSY., POWER TILT	1	1	
F-7-10	16	HZY9-38552-000	BRACKET, RELAY	1	1	
F-7-10	17	HZY9-38553-003	GROMMET, RELAY BRACKET	4	4	
F-7-10	18	HZY9-38580-003	RELAY ASSY., MAIN	1	1	
F-7-10	19	HSZ5-91531-003	CLIP, TUBE, 3.5	1	1	
F-7-10	21	HZW9-90011-000	BOLT, FLANGE, 6X14(CT200)	2	2	
F-7-10	22	HZW9-90013-000	BOLT, FLANGE, 6X12	1	1	
F-7-10	24	HZW5-90018-000	BOLT, FLANGE, 6X20	2	2	
F-7-10	25	HZY3-90021-000	BOLT, FLANGE, 6X14	4	4	
F-7-10	28	HZY3-90107-000	BOLT, FLANGE, 8X18	1	1	
F-7-10	30	HZW1-90203-000	NUT-WASHER, 8MM	1	1	
F-7-10	32	HZY3-90405-000	WASHER, PLAIN, 8MM	1	1	
F-7-10	33	HSA0-90683-003	CLIP, WIRE HARNESS, 25MM	1	1	
F-7-10	35	HZV5-91553-010	COLLAR, C.D.I. UNIT CASE	4	4	
F-7-10	36	HZY9-91555-000	COLLAR, P.T.T. RELAY	2	2	
F-7-10	42	HZW2-90003-000	BOLT-WASHER, 6X27(CT200)	4	4	

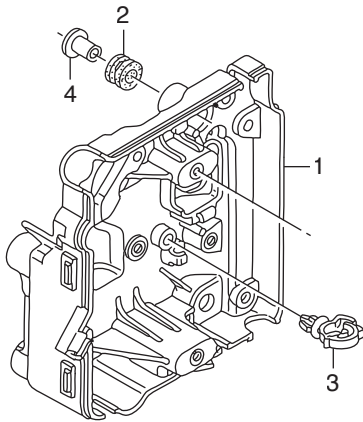

E-20-10

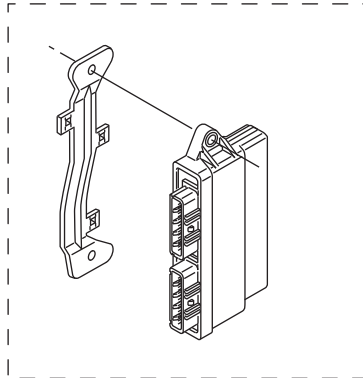

FR. →

F-12 ←

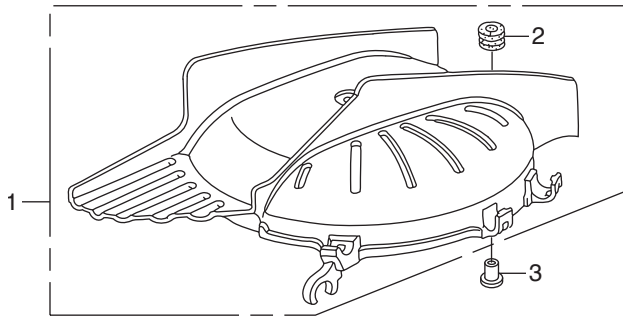

E-19 ←

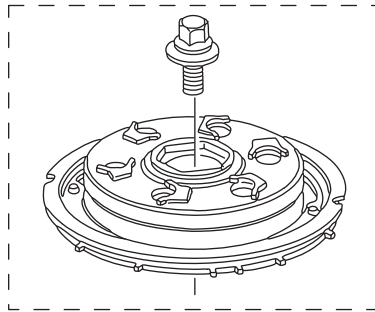

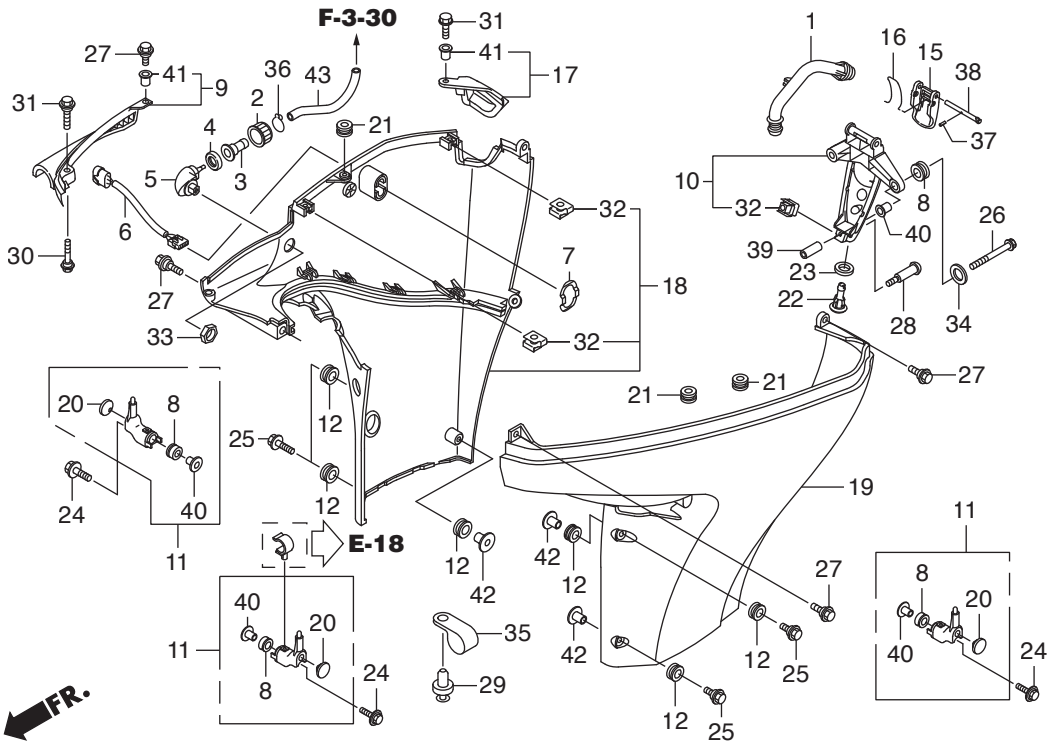
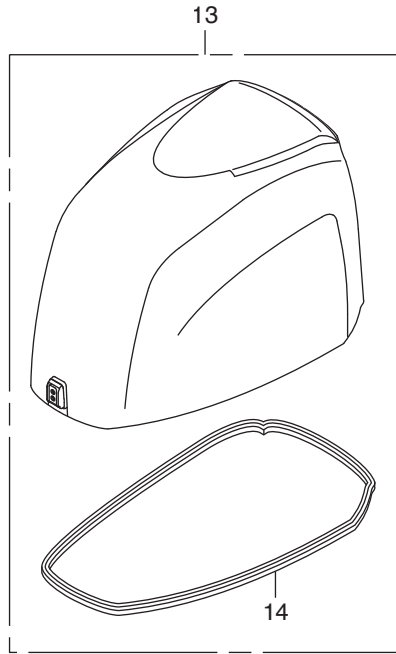

Ref.No.	Part No.	Description	Q' ty		Remarks	
			BET75A	BET90A		
F-8	1	HZY9-18211-000	PORT, IDLE EXHAUST	1	1	
F-8	2	HZY3-19270-000	NUT, WATER MOUTH	1	1	
F-8	3	HZY3-19271-000	JOINT, WATER HOSE	1	1	
F-8	4	HZY3-19272-000	SEAT, WATER MOUTH	1	1	
F-8	5	HZY6-19289-000	CAP, WATER JOINT	1	1	
F-8	6	HZY9-35640-003	SWITCH ASSY., POWER TILT	1	1	
F-8	7	HZY9-35645-000	STAY, POWER TILT SWITCH	1	1	
F-8	8	HZV5-40102-000	GROMMET, UNDER CASE	5	5	
F-8	9	HZY9-40151-000ZD	COVER, SEPARATE FRONT	1	1	*T107* BAY BLUE
F-8	10	HZY9-40155-010	BRACKET, UNDER COVER	1	1	
F-8	11	HZY9-40165-010	STOPPER ASSY., ENGINE SIDE	3	3	
F-8	12	HMB6-61102-631	RUBBER, FENDER MOUNTING	6	6	
F-8	13	HZY9-63100-020ZC	COVER ASSY., ENGINE	1	1	*T107* BAY BLUE
F-8	14	HZY9-63102-000	SEAL, ENGINE COVER	1	1	
F-8	15	HZY9-63232-010	LEVER, FASTENER	1	1	
F-8	16	HZY9-63237-000	WIRE, FASTENER	1	1	
F-8	17	HZY9-63347-010ZC	COVER, PLUG MAINTENANCE	1	1	*T107* BAY BLUE
F-8	18	HZY9-63711-010ZC	COVER COMP., R. ENGINE UNDER	1	1	*T107* BAY BLUE
F-8	19	HZY9-63716-010ZC	COVER COMP., L. ENGINE UNDER	1	1	*T107* BAY BLUE
F-8	20	H965-77212-000	RUBBER, SEAT SIDE	3	3	
F-8	21	HGJ5-80103-000	GROMMET, ENGINE COVER	3	3	
F-8	22	HZY9-82873-000	GROMMET, WATER CHECK	1	1	
F-8	23	HZY9-82874-000	SEAL, WATER CHECK GROMMET	1	1	
F-8	24	HZW2-90003-000	BOLT-WASHER, 6X27(CT200)	3	3	
F-8	25	HZY9-90103-000	BOLT-WASHER, 6X22	6	6	
F-8	26	HZY9-90106-000	BOLT, FLANGE, 6X55	2	2	
F-8	27	HZY3-90111-000	BOLT, SPECIAL, 6X17	6	6	
F-8	28	HZY9-90113-003	BOLT, RR. BRACKET	1	1	
F-8	29	HZV5-90127-003	SCREW, RIVET, 5X10	1	1	

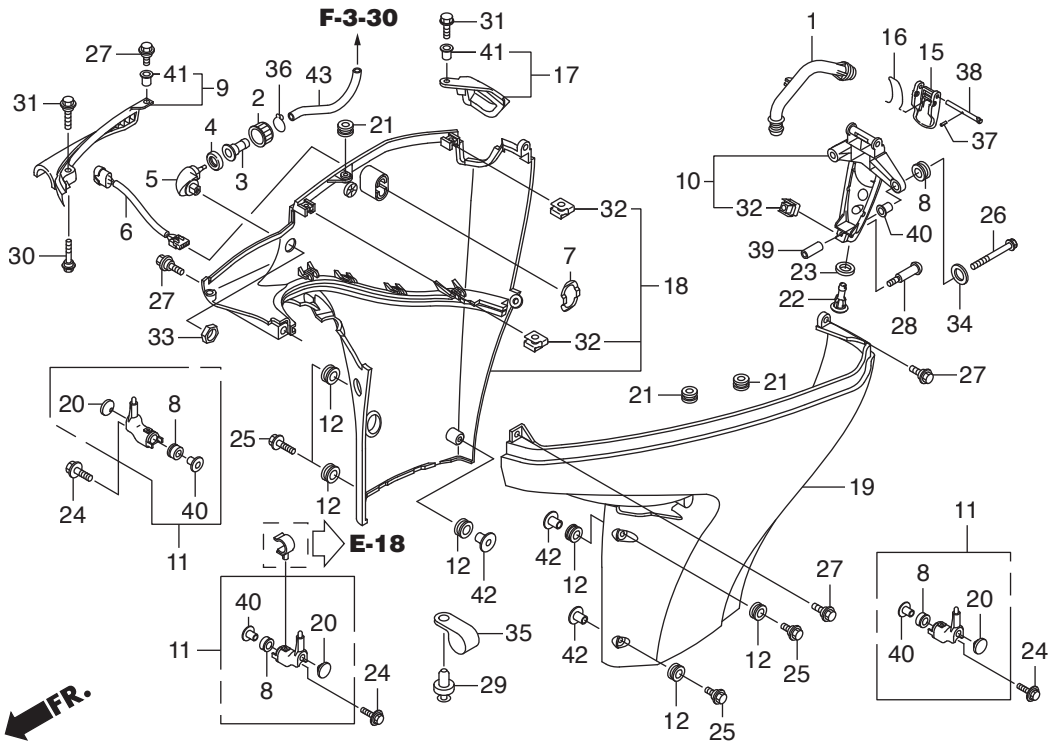
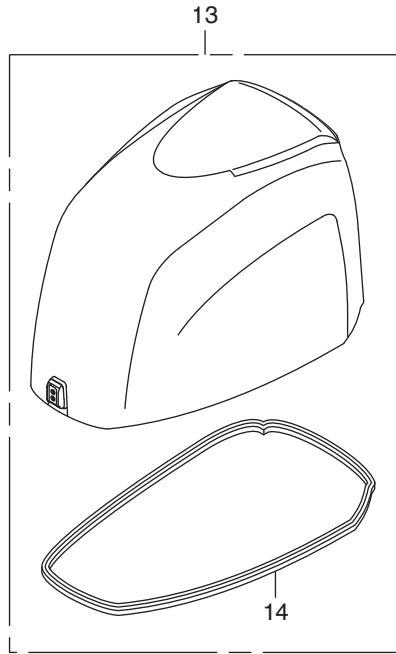

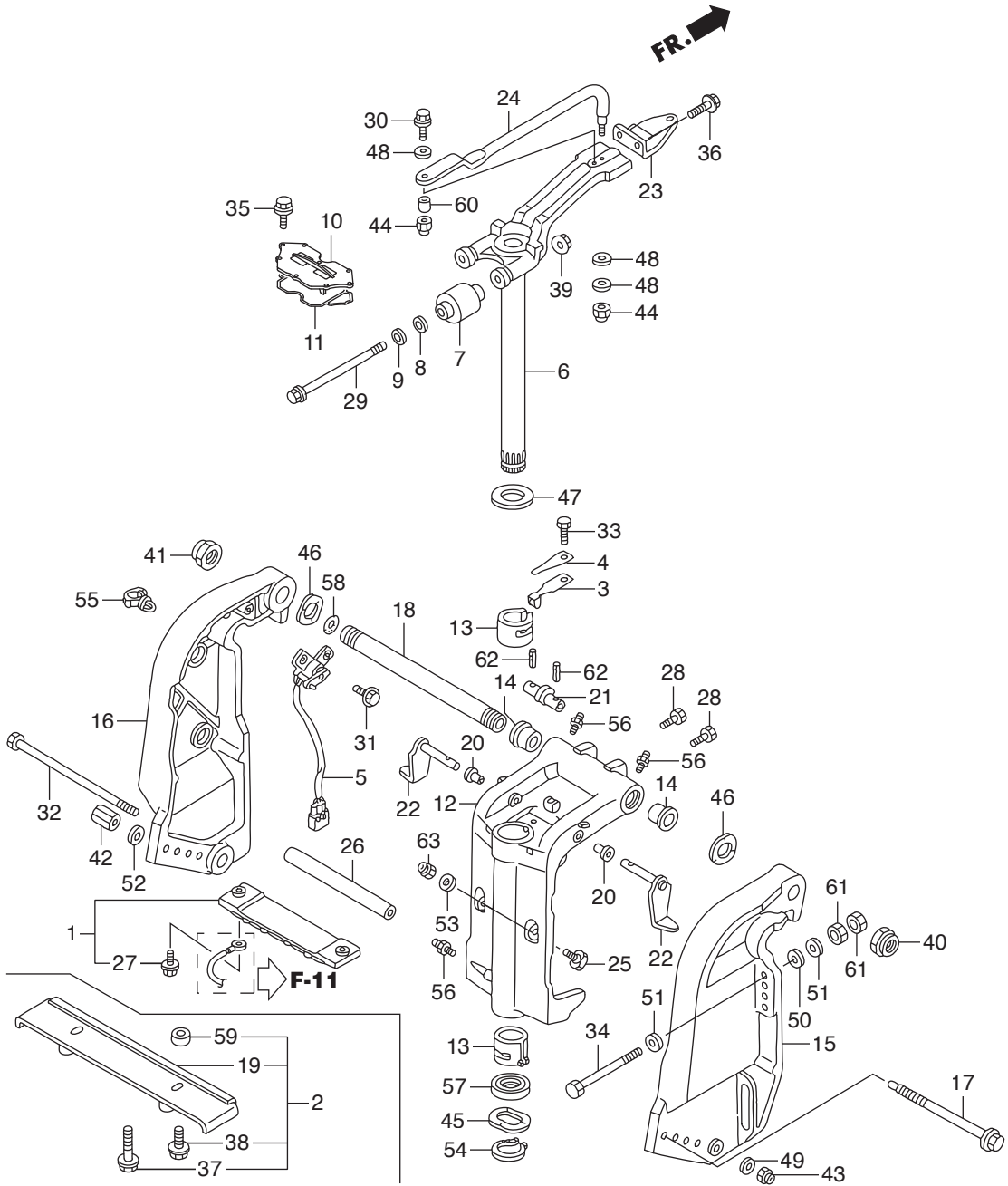

Ref.No.	Part No.	Description	Q' ty		Remarks	
			BET75A	BET90A		
F-10	1	HZW1-06411-020	METAL KIT, ANODE	1	1	
F-10	2	HZY9-06534-000	PLATE KIT, SPLASH	1	1	
F-10	3	HZV1-24210-010	SPRING COMP., CLICK	1	1	
F-10	4	HZV4-24221-010	SPRING, CLICK ASSIST	1	1	
F-10	5	HZY9-35660-003	SENSOR ASSY., TRIM ANGLE	1	1	
F-10	6	HZY9-50100-020	FRAME COMP., MOUNTING	1	1	
F-10	7	HZZ0-50151-000	MOUNT COMP., UPPER RUBBER	2	2	
F-10	8	HZY9-50153-000	RUBBER, UPPER MOUNT STOPPER	2	2	
F-10	9	HZY9-50158-000	STOPPER, UPPER MOUNT	2	2	
F-10	10	HZY9-50166-010	COVER, UPPER MOUNT	1	1	
F-10	11	HZY9-50168-000	SEAL, UPPER MOUNT COVER	1	1	
F-10	12	HZY9-50201-H00ZB	CASE, SWIVEL	1	1	*T107* BAY BLUE
F-10	13	HZZ5-50211-000	LINER, SWIVEL CASE	2	2	
F-10	14	HZW1-50214-000	BUSH, SWIVEL CASE	2	2	
F-10	15	HZY9-50301-020ZC	BRACKET, R. STERN	1	1	*T107* BAY BLUE
F-10	16	HZY9-50311-020ZC	BRACKET, L. STERN	1	1	*T107* BAY BLUE
F-10	17	HZW5-50341-010	ROD, ADJUSTING	1	1	
F-10	18	HZY9-50381-000	SHAFT, TILTING	1	1	
F-10	19	HZY9-50412-000	PLATE COMP., SPLASH	1	1	
F-10	20	HZV5-50522-000	BUSH, TILT ARM	2	2	
F-10	21	HZW1-50527-000	BRACKET, TILTING	1	1	
F-10	22	HZW1-50529-000	STOPPER, TILT	2	2	
F-10	23	HZW1-53234-010	PLATE, STEERING	1	1	
F-10	24	HZW1-53238-010	ROD, STEERING	1	1	
F-10	25	HZW1-56516-000	RECEIVER, THRUST	2	2	
F-10	26	HZW1-56539-000	COLLAR, LOWER CYLINDER	1	1	
F-10	27	HZW9-90009-000	BOLT, FLANGE, 6X23	2	2	
F-10	28	HZW1-90102-000	BOLT, 1/4-28UNF	2	2	
F-10	29	HZY9-90102-000	BOLT, HEX., 12X186	2	2	

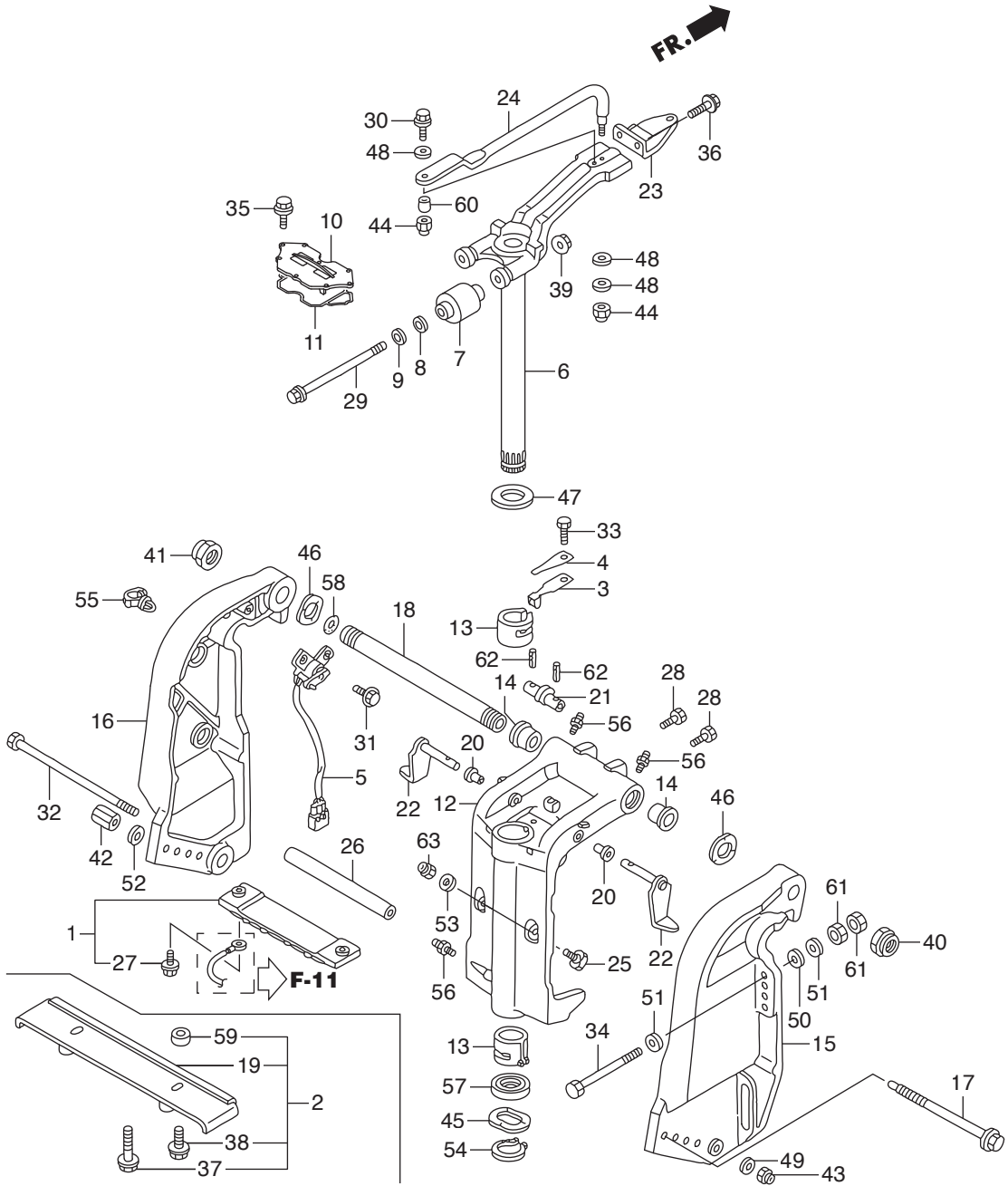

Ref.No.	Part No.	Description	Q' ty		Remarks	
			BET75A	BET90A		
F-10	30	HZW1-90105-000	BOLT, 3/8-24UNF	1	1	
F-10	31	HZW9-90105-000	BOLT, FLANGE, 6X20	2	2	
F-10	32	HZW1-90108-000	BOLT, HEX., 10X235	1	1	
F-10	33	H881-90110-000	BOLT, HEX., 6X14	1	1	
F-10	34	HZZ3-90129-000	BOLT, HEX., 12X119	4	4	
F-10	35	HZW4-90151-000	BOLT, FLANGE, 8X25	8	8	
F-10	36	HZW9-90154-000	BOLT, FLANGE, 10X25	2	2	
F-10	37	HHW1-90214-671	BOLT, FLANGE, 6X25(SUS-D)	2	2	
F-10	38	HHW1-90215-671	BOLT, FLANGE, 6X16	2	2	
F-10	39	HZW5-90302-003	NUT, FLANGE, 12MM	2	2	
F-10	40	HZV5-90304-013	NUT, SELF-LOCK(7/8-14UNF)	1	1	
F-10	41	HZW1-90304-013	NUT, SELF-LOCK(25X2.0)	1	1	
F-10	42	HZW5-90304-000	NUT, ADJUSTER ROD	1	1	
F-10	43	HZW4-90306-003	NUT, FLANGE, 10MM	1	1	
F-10	44	HZV5-90307-003	NUT, SELF-LOCK(3/8-24UNF)	2	2	
F-10	45	HZV5-90501-000	WASHER, WAVE, 40MM	1	1	
F-10	46	HZV5-90502-000	WASHER, WAVE, 26MM	2	2	
F-10	47	HZV5-90504-000	WASHER, THRUST, 34MM	1	1	
F-10	48	HZV4-90514-000	WASHER, 10MM	3	3	
F-10	49	H921-90511-000	WASHER, PLAIN, 10MM	1	1	
F-10	50	HZV5-90552-000	WASHER, PLAIN, 12MM	4	4	
F-10	51	HZV5-90559-000	WASHER, PLAIN, 12MM	8	8	
F-10	52	HZV5-90559-000	WASHER, PLAIN, 12MM	1	1	
F-10	53	HZV5-90563-000	WASHER, PLAIN, 10MM	2	2	
F-10	54	HZW4-90651-000	CIRCLIP, EXTERNAL, 39MM	1	1	
F-10	55	H763-90681-A01	CLIP, WIRE HARNESS	1	1	
F-10	56	HZV7-90951-010	NIPPLE, GREASE	3	3	
F-10	57	HZV5-91256-003	OIL SEAL, 39.5X52X6(ARAI)	1	1	
F-10	58	HZV5-91352-000	O-RING, 15.54X2.26	1	1	

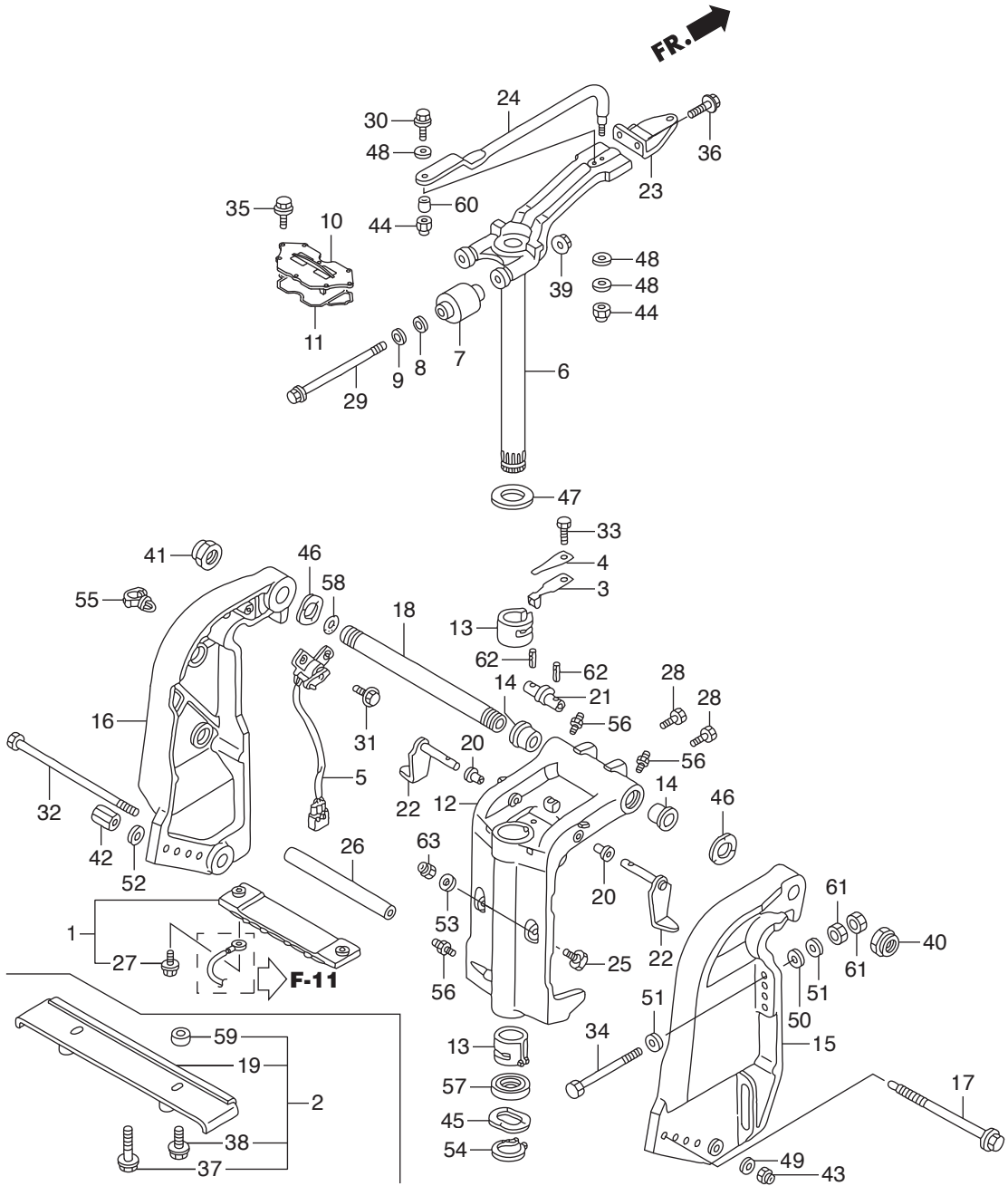

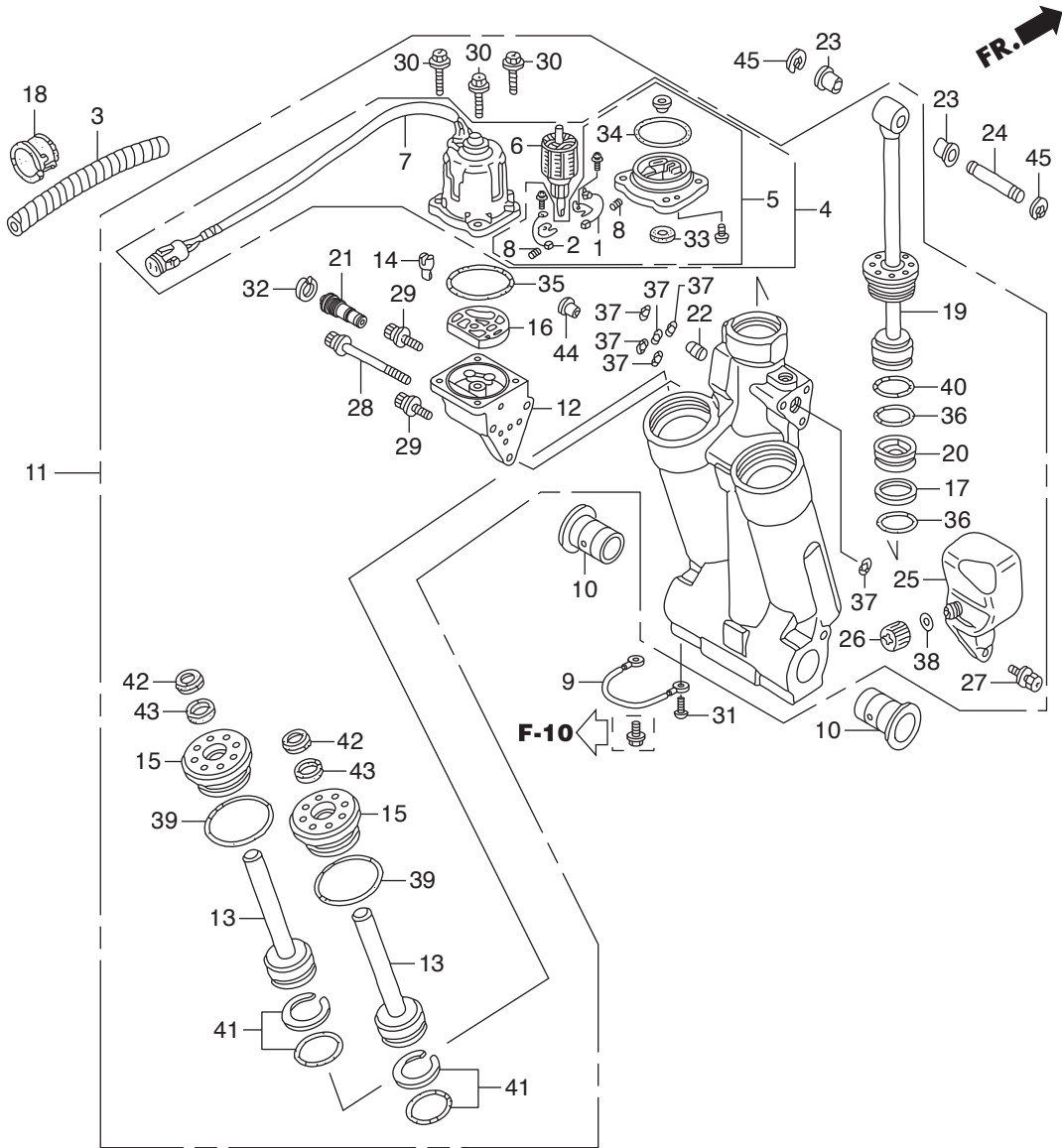

Ref.No.	Part No.	Description	Q' ty		Remarks	
			BET75A	BET90A		
F-11	1	HZY3-30280-003	BREAKER ASSY.	1	1	
F-11	2	HZY3-31106-003	BRUSH ASSY.	1	1	
F-11	3	HZY9-36104-003	TUBE, SPIRAL(12X14.6)	1	1	
F-11	4	HZY9-36120-003	MOTOR ASSY., POWER TILT	1	1	
F-11	5	HZW1-36122-013	BRACKET ASSY.	1	1	
F-11	6	HZW1-36123-013	ARMATURE COMP.	1	1	
F-11	7	HZY9-36129-003	YOKE ASSY.	1	1	
F-11	8	HZV5-36136-821	SPRING, MOTOR	2	2	
F-11	9	HZY3-40219-013	WIRE, LEAD(1.5X116MM)	1	1	
F-11	10	HZV5-50214-003	BUSH, SWIVEL CASE	2	2	
F-11	11	HZY9-56000-013	TRIM-TILT ASSY., POWER	1	1	
F-11	12	HZY9-56100-013	PUMP ASSY.	1	1	
F-11	13	HZW1-56110-701	ROD COMP., PISTON(B)	2	2	
F-11	14	HZW1-56113-701	JOINT, DRIVE	1	1	
F-11	15	HZY9-56115-003	GUIDE COMP., ROD	2	2	
F-11	16	HZW1-56116-701	FILTER B	1	1	
F-11	17	HZV5-56117-821	RING, BACK UP	1	1	
F-11	18	HZV5-56118-820	BUSH, MOTOR CODE	1	1	
F-11	19	HZY9-56120-003	ROD COMP., PISTON	1	1	
F-11	20	HZW1-56130-702	PISTON COMP., FREE	1	1	
F-11	21	HZY9-56170-003	VALVE COMP., MANUAL	1	1	
F-11	22	HZW1-56180-701	VALVE COMP., RESERVOIR	1	1	
F-11	23	HZV5-56513-000	BUSH, LOWER CYLINDER	2	2	
F-11	24	HZW1-56532-000	PIN, UPPER CYLINDER	1	1	
F-11	25	HZW1-56851-703	TANK, OIL	1	1	
F-11	26	HZW1-56860-701	CAP COMP., OIL TANK	1	1	
F-11	27	HZW1-90113-702	BOLT, RECESSED	3	3	
F-11	28	HZW1-90114-702	BOLT, SOCKET(A)	1	1	
F-11	29	HZW1-90115-702	BOLT, SOCKET(B)	2	2	

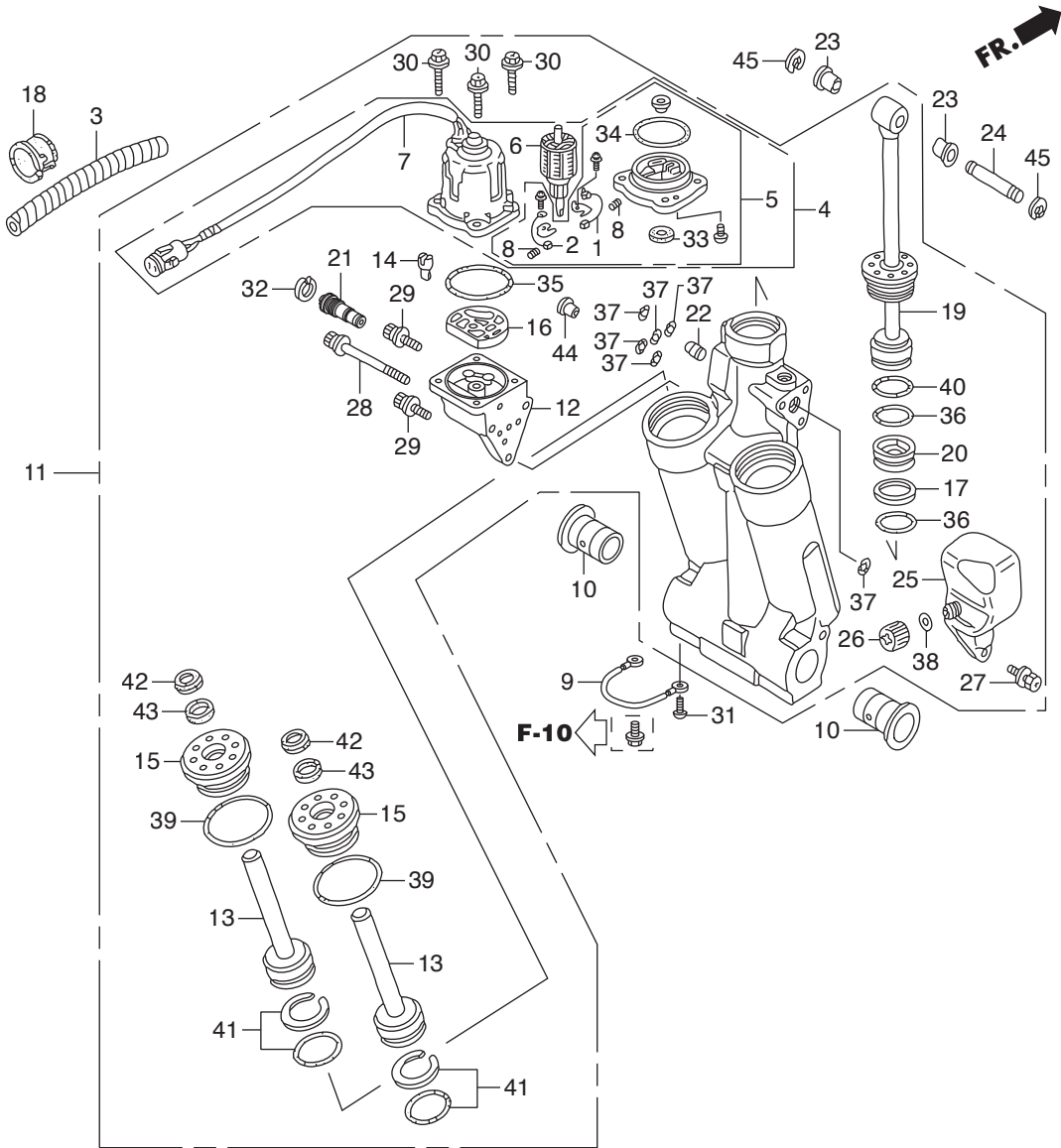

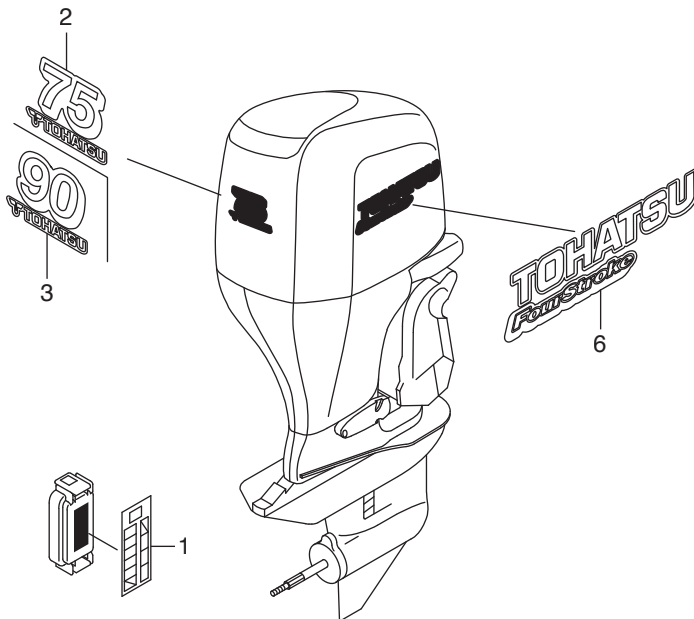
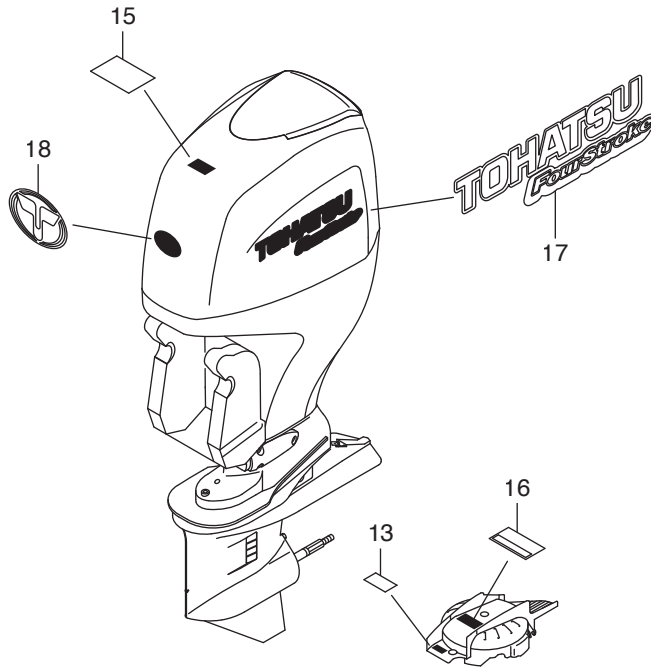

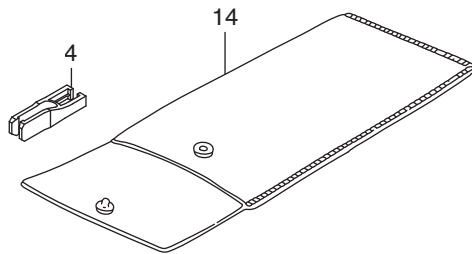
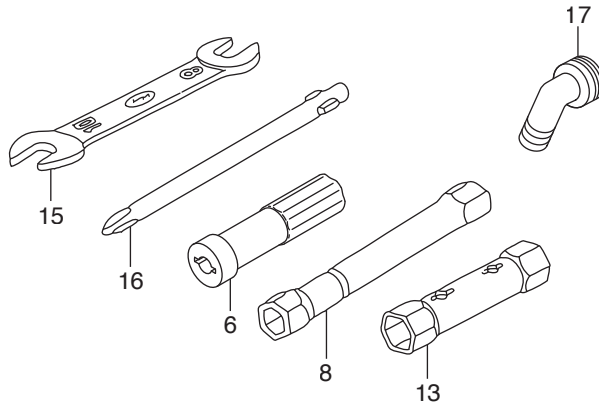
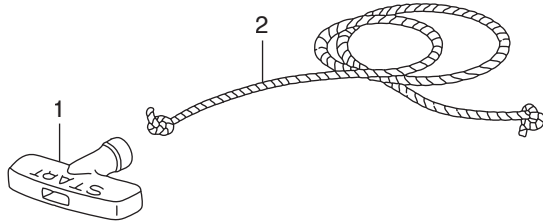

FR. →

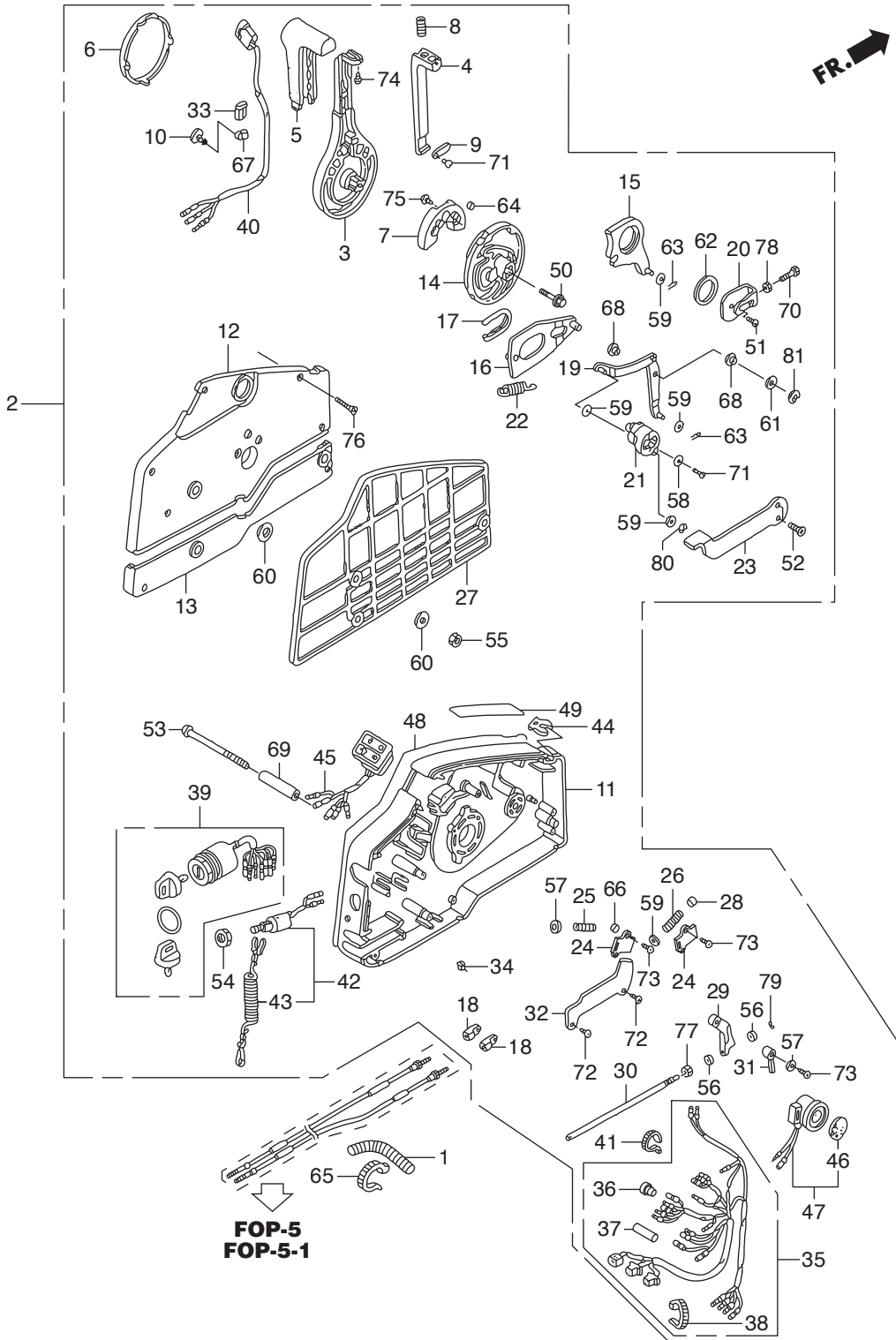

Ref.No.	Part No.	Description	Q' ty		Remarks	
			BET75A	BET90A		
F-15	1	HZW1-17736-000	TUBE, CORRUGATE(28MM)	1	1	
F-15	2	HZZ3-24800-R00	BOX ASSY., REMOTE CONTROL(EU)	1	1	
F-15	3	HZV5-24811-010	HANDLE, REMOTE CONTROL	1	1	
F-15	4	HZV5-24812-000	LEVER, HANDLE LOCK	1	1	
F-15	5	HZV5-24813-000	GRIP, REMOTE CONTROL HANDLE	1	1	
F-15	6	HZV5-24814-010	CAP, HANDLE	1	1	
F-15	7	HZV5-24815-010	BLOCK, NEUTRAL LOCK	1	1	
F-15	8	HZV5-24816-000	SPRING, REMOTE CONTROL HANDLE	1	1	
F-15	9	HZV5-24817-000	PLATE, LEVER SETTING	1	1	
F-15	10	HZV5-24818-003	CLAMP, HARNESS	1	1	
F-15	11	HZV5-24820-010	HOUSING COMP., REMOTE CONTROL	1	1	BOX(A)
F-15	12	HZV5-24830-010	HOUSING COMP., REMOTE CONTROL	1	1	BOX(B)
F-15	13	HZV5-24836-000	HOUSING, REMOTE CONTROL BOX(C)	1	1	
F-15	14	HZV5-24841-000	WHEEL, CONTROL	1	1	
F-15	15	HZV5-24845-000	ARM COMP., SHIFT LINK	1	1	
F-15	16	HZV5-24850-000	PLATE COMP., SLIDING	1	1	
F-15	17	HZV5-24854-000	COLLAR, SLIDING PLATE	1	1	
F-15	18	HZV5-24855-000	PIVOT, SHIFT	2	2	
F-15	19	HZV5-24860-000	ARM COMP., LINK JOINT	1	1	
F-15	20	HZV5-24865-000	BRACKET, LINK JOINT	1	1	
F-15	21	HZV5-24875-000	WHEEL, ACCELERATOR	1	1	
F-15	22	HZV5-24876-000	SPRING, ACCELERATOR WHEEL	1	1	
F-15	23	HZV5-24878-000	LEVER, IDLE	1	1	
F-15	24	HZV5-24881-000	PLATE, SPRING SETTING	2	2	
F-15	25	HZV5-24883-000	SPRING, SHIFT CLICK	1	1	
F-15	26	HZV5-24884-000	SPRING, CHOKE RETURN	1	1	
F-15	27	HZV5-24885-000	SPACER, REMOTE CONTROL BOX	1	1	
F-15	28	HZV5-24887-000	SPACER, CLICK SPRING	1	1	
F-15	29	HZV5-24891-000	BLOCK, THROTTLE FRICTION	1	1	

FR. →

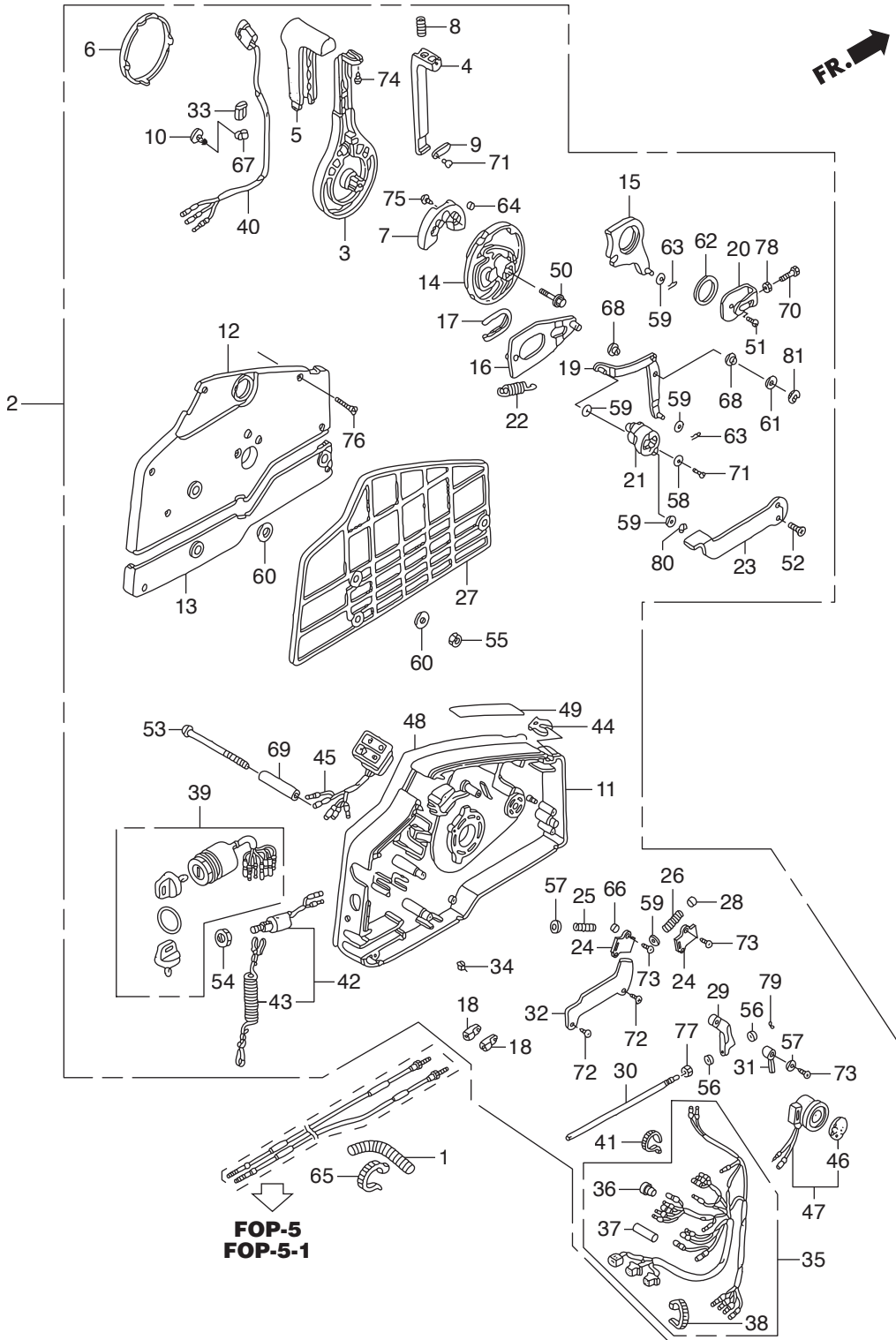

Ref.No.	Part No.	Description	Q' ty		Remarks	
			BET75A	BET90A		
F-15	30	HZV5-24892-000	BOLT, FRICTION	1	1	
F-15	31	HZV5-24894-000	SPACER, NEUTRAL SWITCH	1	1	
F-15	32	HZV5-24895-000	CLAMP, POWER TILT CORD	1	1	
F-15	33	HZV5-24897-000	PIPE, HARNESS GUIDE	1	1	
F-15	34	HZV5-24898-000	SPACER, CABLE CLAMP	1	1	
F-15	35	HZZ5-32530-000	CABLE ASSY., REMOTE CONTROL(B)	1	1	
F-15	36	HZV5-32823-003	PLUG, INNER CONNECTOR	7	7	
F-15	37	HZV5-32824-003	PLUG, OUTER CONNECTOR	1	1	
F-15	38	H952-32901-770	TIE, CABLE(NATURAL)(2.4X92)	1	1	
F-15	39	HZZ3-35100-R11	SWITCH ASSY., COMBINATION	1	1	
F-15	40	HZV5-35370-823	SWITCH ASSY., POWER TRIM-TILT	1	1	
F-15	41	HMG9-35701-950	BAND(BLACK 3.5X140)	1	1	
F-15	42	HZV5-36180-033	SWITCH ASSY., EMERGENCY STOP	1	1	
F-15	43	HZV4-36182-651	CORD COMP., EMERGENCY	1	1	
F-15	44	HZV4-36187-652	CLIP, EMERGENCY LOCK	2	2	
F-15	45	HZZ5-37210-013	LAMP ASSY., INDICATION	1	1	
F-15	46	H341-38403-672	PLATE, WINKER BUZZER	1	1	
F-15	47	HZV5-38410-003	BUZZER COMP., WARNING	1	1	
F-15	48	HZZ3-87701-R00	PLATE, REMOTE CONTROL	1	1	
F-15	49	HZW9-87702-800	MARK, FAST IDLE	1	1	
F-15	50	HZW9-90008-000	BOLT, FLANGE, 8X35	1	1	
F-15	51	HMM4-90105-000	SCREW, PAN, 6X10	1	1	
F-15	52	HZW4-90108-000	SCREW, FLAT, 5X12	2	2	
F-15	53	HZV5-90125-000	SCREW, 6X95	3	3	
F-15	54	H921-90302-000	NUT, HEX., 16MM	1	1	
F-15	55	HZV4-90304-000	NUT, HEX., 6MM	3	3	
F-15	56	HZW4-90401-000	WASHER, PLAIN, 4MM	2	2	
F-15	57	HZW4-90402-000	WASHER, PLAIN, 5MM	2	2	
F-15	58	HZV4-90502-000	WASHER, PLAIN, 5MM	1	1	

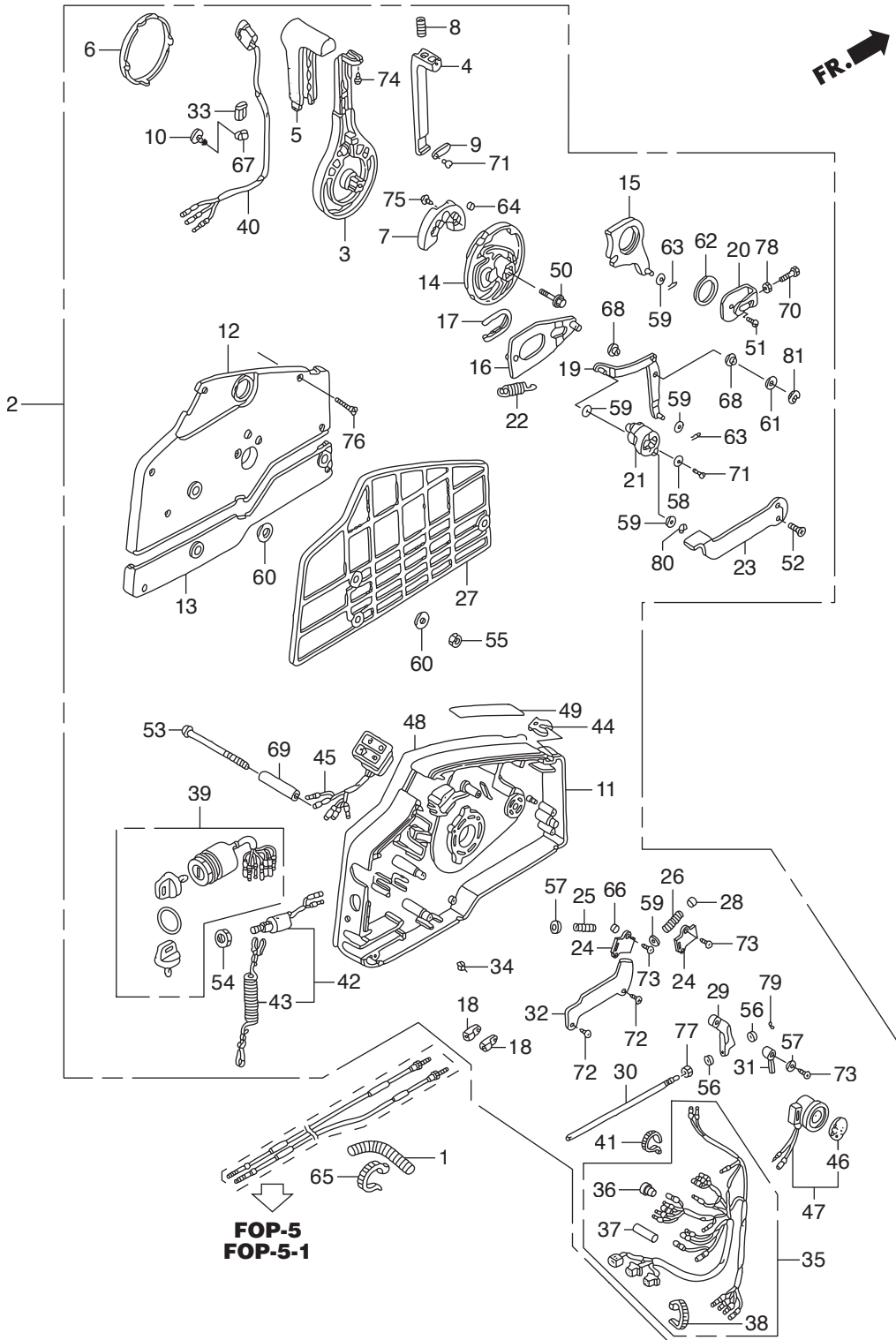

Ref.No.	Part No.	Description	Q' ty		Remarks	
			BTT75A	BTT90A		
F-15	59	H921-90504-010	WASHER, PLAIN, 6MM	5	5	
F-15	60	H921-90512-010	WASHER, 6MM	6	6	
F-15	61	H921-90518-000	WASHER, PLAIN, 8MM	1	1	
F-15	62	HZV5-90557-000	WASHER, 28MM	1	1	
F-15	63	HZV5-90751-000	PIN, LOCK, 6MM	2	2	
F-15	64	HZV5-90772-000	PIN, 6X6	1	1	
F-15	65	HMG9-91058-681	BAND, SELF LOCK	2	2	
F-15	66	HZV5-91151-000	ROLLER, CLICK	1	1	
F-15	67	HSB6-91475-000	CLIP, WIRE HARNESS(6.3MM)	1	1	
F-15	68	HZV5-91567-000	COLLAR, LINK JOINT	2	2	
F-15	69	HZV5-91570-000	COLLAR, DISTANCE, 6X10X43.5	3	3	
F-15	70	HCO-92101-05016-4J	BOLT, HEX., 5X16	1	1	
F-15	71	HCO-93500-05010-4J	SCREW, PAN, 5X10	2	2	
F-15	72	HCO-93901-250J0	SCREW, TAPPING, 5X8	2	2	
F-15	73	HCO-93901-251J0	SCREW, TAPPING, 5X10	3	3	
F-15	74	HCO-93901-252J0	SCREW, TAPPING, 5X12	1	1	
F-15	75	HCO-93903-262J0	SCREW, TAPPING, 6X16	2	2	
F-15	76	HCO-93905-255J0	SCREW, TAPPING, 5X25	7	7	
F-15	77	HCO-94001-06490-0S	NUT, HEX., 6MM	1	1	
F-15	78	HCO-94002-05490-0S	NUT, HEX., 5MM	1	1	
F-15	79	HCO-94540-03029	E-RING, 3MM	1	1	
F-15	80	HCO-94540-04029	E-RING, 4MM	1	1	
F-15	81	HCO-94540-07029	E-RING, 7MM	1	1	

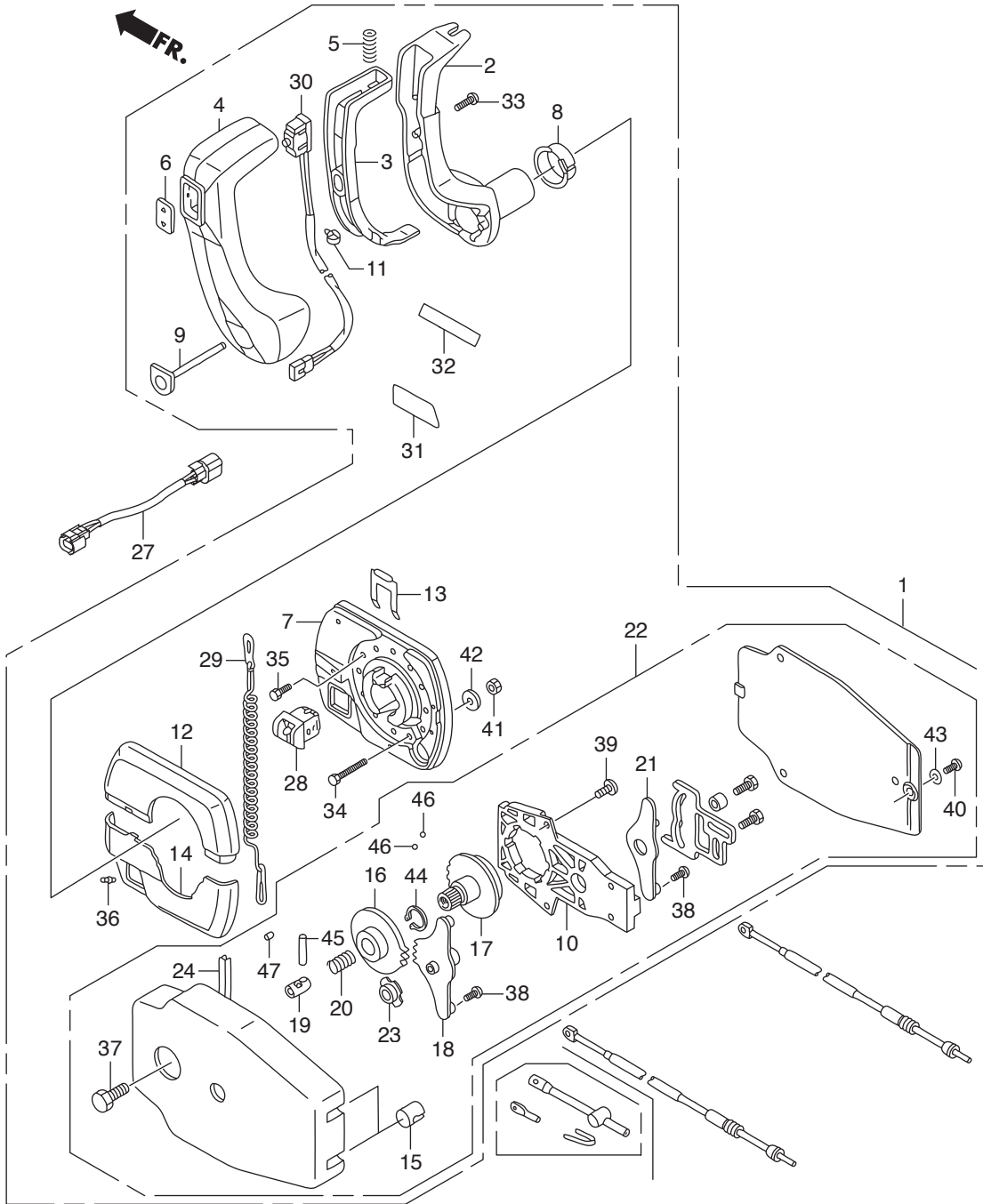

Ref.No.	Part No.	Description	Q' ty		Remarks	
			BET75A	BET90A		
F-15-1	1	HZW1-24800-V21	BOX ASSY., REMOTE CONTROL	1	1	(PANEL MOUNT)
F-15-1	2	HZW1-24811-V21	HANDLE, REMOTE CONTROL	1	1	
F-15-1	3	HZW1-24812-V21	LEVER, HANDLE LOCK	1	1	
F-15-1	4	HZW1-24813-V21	GRIP, REMOTE CONTROL HANDLE	1	1	
F-15-1	5	HZW1-24816-V21	SPRING, REMOTE CONTROL HANDLE	1	1	
F-15-1	6	HZW1-24819-V21	COVER, GRIP	1	1	
F-15-1	7	HZW1-24820-V21	HOUSING ASSY., REMOTE CONTROL	1	1	BOX(A)
F-15-1	8	HZW1-24821-003	BUSHING	1	1	
F-15-1	9	HZW1-24822-V21	BUTTON, THROTTLE	1	1	
F-15-1	10	HZW1-24825-V01	FRAME ASSY., REMOTE CONTROL	1	1	BOX
F-15-1	11	HZW1-24829-003	BAND, CABLE(B)	1	1	
F-15-1	12	HZW1-24830-V21	HOUSING, REMOTE CONTROL BOX(B)	1	1	
F-15-1	13	HZW1-24834-003	RETAINER	1	1	
F-15-1	14	HZW1-24836-V21	HOUSING, REMOTE CONTROL BOX(C)	1	1	
F-15-1	15	HZW1-24839-V01	GROMMET	2	2	
F-15-1	16	HZW1-24841-V01	WHEEL, CONTROL	1	1	
F-15-1	17	HZW1-24843-V01	SHAFT, HANDLE	1	1	
F-15-1	18	HZW1-24845-V01	ARM ASSY., SHIFT LINK	1	1	
F-15-1	19	HZW1-24847-V01	SHAFT, GEAR SHIFT	1	1	
F-15-1	20	HZW1-24848-V01	SPRING, GEAR SHIFT	1	1	
F-15-1	21	HZW1-24865-V01	ARM ASSY., THROTTLE LINK	1	1	
F-15-1	22	HZW1-24870-V21	HOUSING ASSY., INNER	1	1	(PANEL MOUNT)
F-15-1	23	HZW1-24873-V01	BUSH	1	1	
F-15-1	24	HZW1-24883-V01	SPRING, SHIFT CLICK	5	5	
F-15-1	27	HZW5-32167-650	HARNESS ASSY., POWER TRIM-TILT	1	1	
F-15-1	28	HZW1-35180-003	SWITCH ASSY., EMERGENCY STOP	1	1	
F-15-1	29	HZW1-35182-003	CORD COMP., EMERGENCY	1	1	
F-15-1	30	HZW1-35370-V01	SWITCH ASSY., POWER TRIM-TILT	1	1	(A)
F-15-1	31	HZW1-87705-003	MARK, REMOTE CONTROL(A)(PANEL)	1	1	

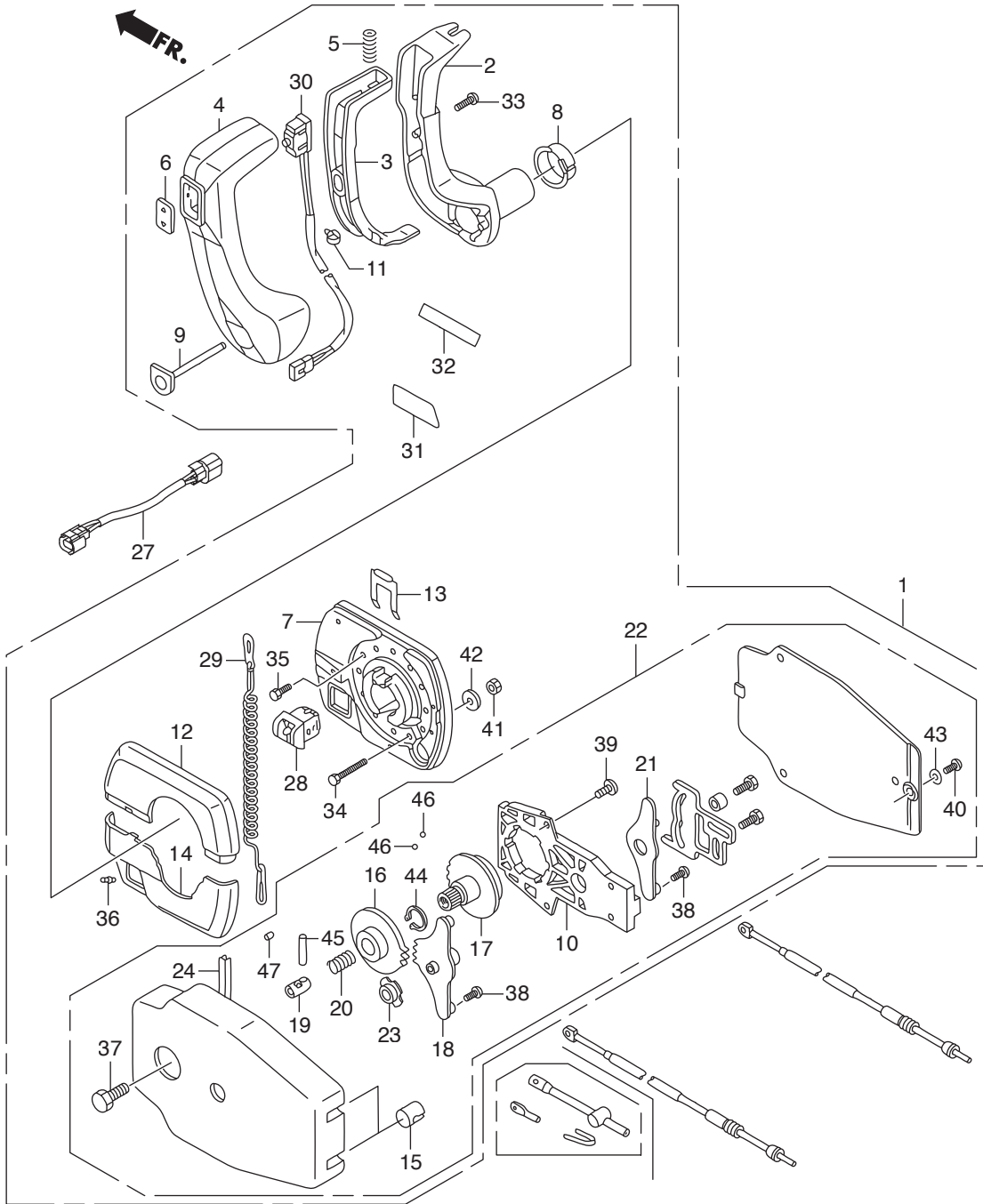

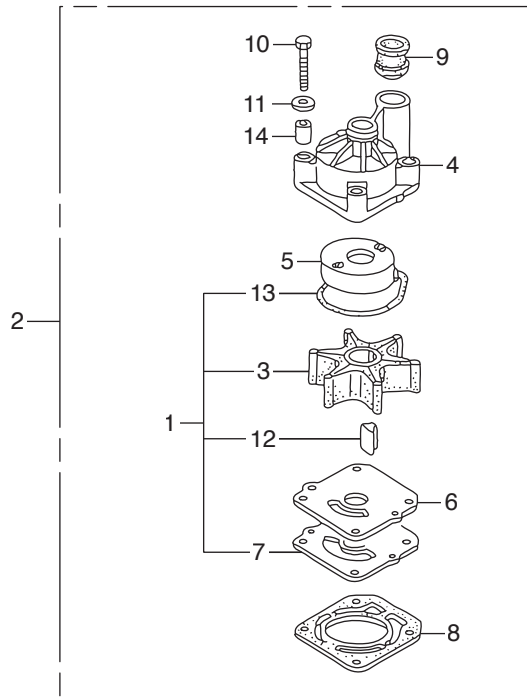

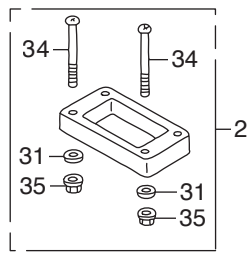
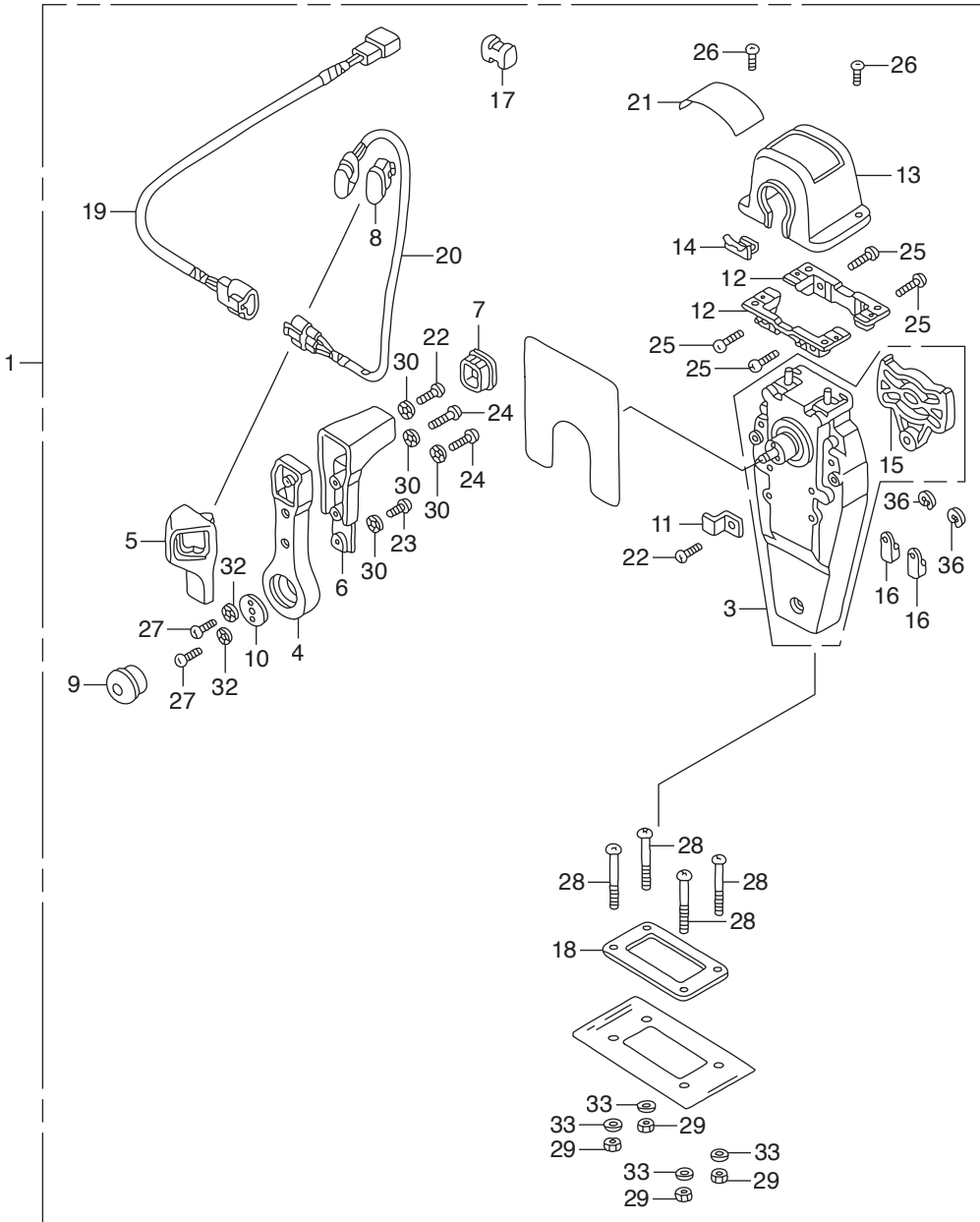

Ref.No.	Part No.	Description	Q' ty		Remarks	
			BET75A	BET90A		
FOP-4	1	HZZ3-06240-R30	BOX KIT, REMOTE CONTROL	1	1	(TOP MOUNT SINGLE)(R)
FOP-4	2	HZW5-06241-U00	SPACER KIT, REMOTE CONTROL BOX	1	1	(TOP MOUNT SINGLE)
FOP-4	3	HZW5-24810-U01	HOUSING ASSY., L. INNER	1	1	(TOP MOUNT)
FOP-4	4	HZW5-24811-U01	HANDLE, REMOTE CONTROL	1	1	
FOP-4	5	HZW5-24812-U01	COVER, L. GRIP	1	1	
FOP-4	6	HZW5-24813-U01	GRIP, REMOTE CONTROL HANDLE	1	1	
FOP-4	7	HZW5-24814-U01	CAP, GRIP	1	1	
FOP-4	8	HZW5-24815-U01	CAP, SWITCH	1	1	
FOP-4	9	HZW5-24816-U01	BUTTON, THROTTLE	1	1	
FOP-4	10	HZW5-24817-U01	PLATE, HANDLE	1	1	
FOP-4	11	HZW5-24818-U01	PLATE, CABLE CLAMP	1	1	
FOP-4	12	HZW5-24819-U01	BRACKET, REMOTE CONTROL	2	2	HOUSING
FOP-4	13	HZZ3-24820-R11	HOUSING COMP., REMOTE CONTROL	1	1	BOX
FOP-4	14	HZW5-24825-U01	HOUSING, LEAD	1	1	
FOP-4	15	HZW5-24826-U01	PLATE, DWELL	1	1	
FOP-4	16	HZW5-24831-U01	TERMINAL, CABLE	2	2	
FOP-4	17	HZW5-24832-U01	SPACER, CABLE CLAMP	1	1	
FOP-4	18	HZW5-24834-U01	PACKING, SINGLE	1	1	
FOP-4	19	HZW7-32530-U00	SUB HARNESS ASSY., POWER	1	1	TRIM-TILT(A)
FOP-4	20	HZW5-35370-U02	SWITCH ASSY., POWER TRIM-TILT	1	1	(A)
FOP-4	21	HZZ3-87703-R81	MARK, REMOTE CONTROL(SINGLE)	1	1	
FOP-4	22	HZW5-90101-U00	SCREW, PAN, 5X16	2	2	
FOP-4	23	HZW5-90102-U00	SCREW, PAN, 5X10	1	1	
FOP-4	24	HZW5-90103-U01	SCREW, PAN, 5X20	2	2	
FOP-4	25	HZW5-90104-U00	SCREW, PAN, 5X18	4	4	
FOP-4	26	HZW5-90105-U01	SCREW, PAN, 4X10	2	2	
FOP-4	27	HZW5-90106-U00	SCREW, PAN, 6X18	2	2	
FOP-4	28	HZW5-90107-U00	SCREW, PAN, 5X40	4	4	
FOP-4	29	HZW5-90301-U00	NUT, HEX., 5MM	4	4	

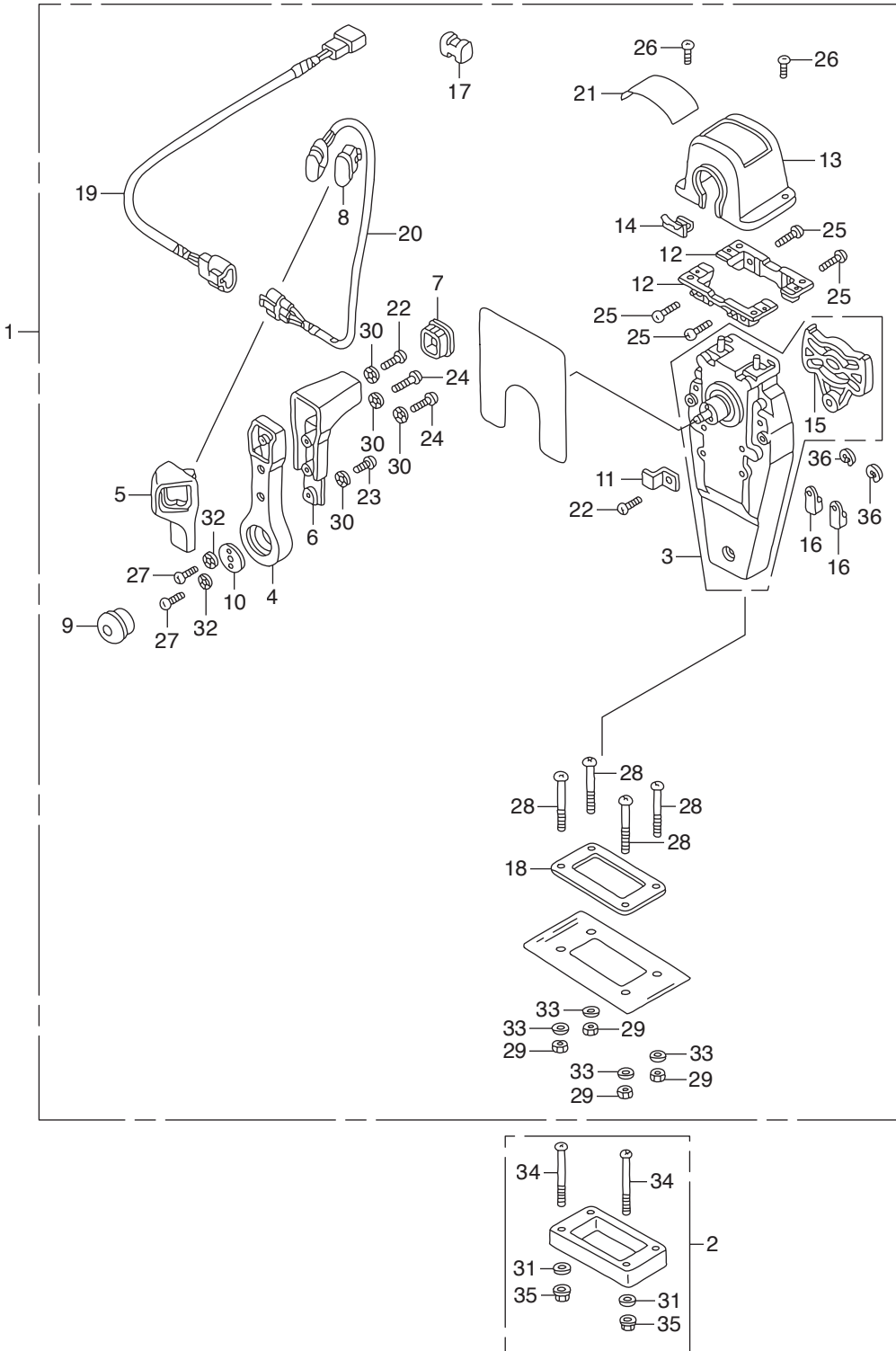

Ref.No.	Part No.	Description	Q' ty		Remarks	
			BET75A	BET90A		
FOP-4-2	1	HZZ3-06240-R60	BOX KIT, REMOTE CONTROL	1	1	(TOP MOUNT DUAL)(R.)
FOP-4-2	2	HZW5-06241-U10	SPACER KIT, REMOTE CONTROL BOX	1	1	(TOP MOUNT DUAL)
FOP-4-2	3	HZW5-24810-U01	HOUSING ASSY., L. INNER	1	1	(TOP MOUNT)
FOP-4-2	4	HZW5-24810-U11	HOUSING ASSY., R. INNER	1	1	(TOP MOUNT)
FOP-4-2	5	HZW5-24811-U01	HANDLE, REMOTE CONTROL	2	2	
FOP-4-2	6	HZW5-24812-U01	COVER, L. GRIP	1	1	
FOP-4-2	7	HZW5-24813-U01	GRIP, REMOTE CONTROL HANDLE	2	2	
FOP-4-2	8	HZW5-24813-U21	COVER, DUAL GRIP	1	1	
FOP-4-2	9	HZW5-24814-U01	CAP, GRIP	2	2	
FOP-4-2	10	HZW5-24816-U01	BUTTON, THROTTLE	2	2	
FOP-4-2	11	HZW5-24817-U01	PLATE, HANDLE	2	2	
FOP-4-2	12	HZW5-24818-U01	PLATE, CABLE CLAMP	1	1	
FOP-4-2	13	HZW5-24819-U01	BRACKET, REMOTE CONTROL	2	2	HOUSING
FOP-4-2	14	HZZ3-24820-R21	HOUSING COMP., REMOTE CONTROL	1	1	BOX(DUAL)
FOP-4-2	15	HZW5-24825-U01	HOUSING, LEAD	2	2	
FOP-4-2	16	HZW5-24826-U01	PLATE, DWELL	2	2	
FOP-4-2	17	HZW5-24831-U01	TERMINAL, CABLE	4	4	
FOP-4-2	18	HZW5-24832-U01	SPACER, CABLE CLAMP	2	2	
FOP-4-2	19	HZW5-24834-U21	PACKING, DUAL	1	1	
FOP-4-2	20	HZW7-32530-U00	SUB HARNESS ASSY., POWER	1	1	TRIM-TILT(A)
FOP-4-2	21	HZW7-32530-U10	SUB HARNESS ASSY., POWER	1	1	TRIM-TILT(B)
FOP-4-2	22	HZW5-35370-U02	SWITCH ASSY., POWER TRIM-TILT	1	1	(A)
FOP-4-2	23	HZW5-35370-U12	SWITCH ASSY., POWER TRIM-TILT	1	1	(B)
FOP-4-2	24	HZZ3-87703-R01	MARK, REMOTE CONTROL(DUAL)	1	1	
FOP-4-2	25	HZW5-90101-U00	SCREW, PAN, 5X16	3	3	
FOP-4-2	26	HZW5-90102-U00	SCREW, PAN, 5X10	2	2	
FOP-4-2	27	HZW5-90103-U01	SCREW, PAN, 5X20	4	4	
FOP-4-2	28	HZW5-90104-U00	SCREW, PAN, 5X18	4	4	
FOP-4-2	29	HZW5-90105-U01	SCREW, PAN, 4X10	4	4	

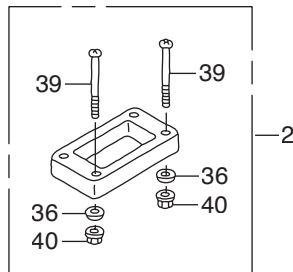
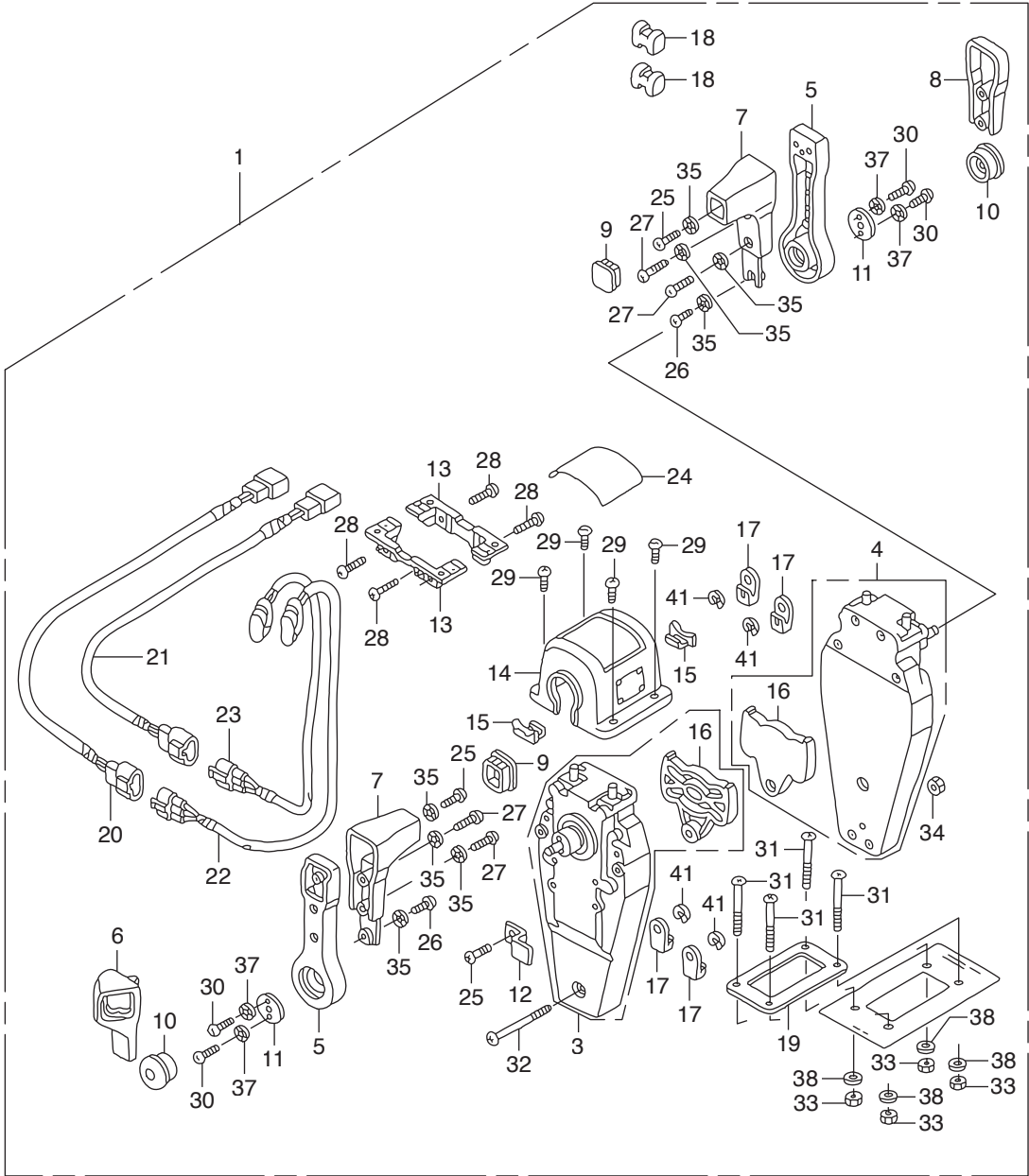

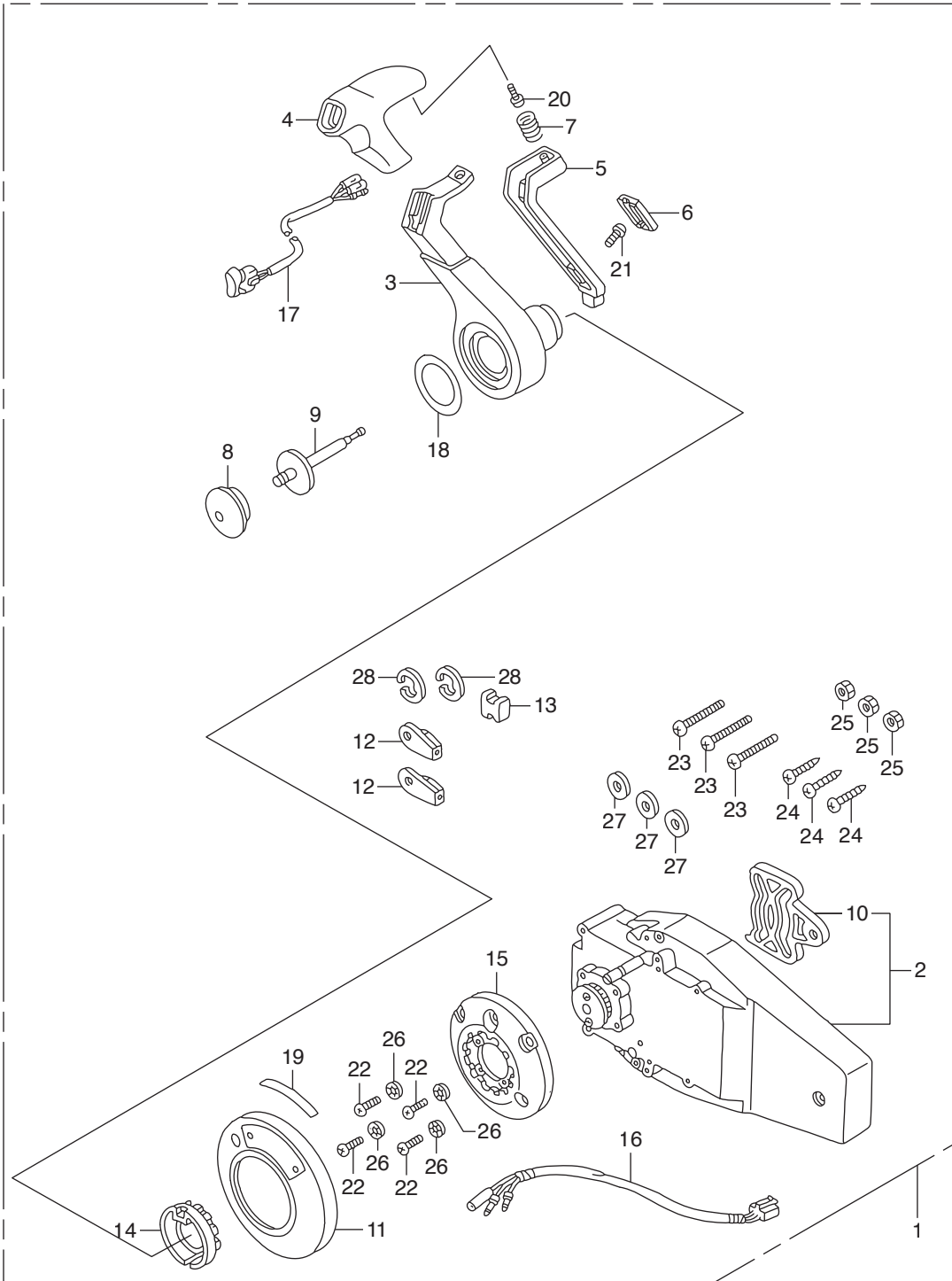

Ref.No.	Part No.	Description	Q' ty		Remarks	
			BET75A	BET90A		
FOP-4-4	1	HZZ3-06240-R40	BOX KIT, REMOTE CONTROL	1	1	(FLUSH MOUNT)(R.)
FOP-4-4	2	HZW7-24810-U01	HOUSING ASSY., R. INNER	1	1	(FLUSH MOUNT)
FOP-4-4	3	HZW7-24811-U01	HANDLE, REMOTE CONTROL	1	1	
FOP-4-4	4	HZW7-24812-U01	COVER, GRIP	1	1	
FOP-4-4	5	HZW7-24813-U01	ARM, NEUTRAL LOCK	1	1	
FOP-4-4	6	HZW7-24814-U01	COVER, LOCK ARM	1	1	
FOP-4-4	7	HZW7-24815-U01	SPRING, NEUTRAL LOCK ARM	1	1	
FOP-4-4	8	HZW5-24816-U01	BUTTON, THROTTLE	1	1	
FOP-4-4	9	HZW7-24817-U01	SHAFT, THROTTLE BUTTON	1	1	
FOP-4-4	10	HZW5-24826-U01	PLATE, DWELL	1	1	
FOP-4-4	11	HZZ3-24830-R41	COVER ASSY.	1	1	
FOP-4-4	12	HZW5-24831-U01	TERMINAL, CABLE	2	2	
FOP-4-4	13	HZW5-24832-U01	SPACER, CABLE CLAMP	1	1	
FOP-4-4	14	HZW7-24832-U01	HOLDER, NEUTRAL LOCK	1	1	
FOP-4-4	15	HZW7-24833-U01	BASE	1	1	
FOP-4-4	16	HZW7-32530-U20	SUB HARNESS ASSY., POWER	1	1	TRIM-TILT(C)
FOP-4-4	17	HZW7-35370-U02	SWITCH ASSY., POWER TRIM-TILT	1	1	(C)
FOP-4-4	18	HZZ3-87701-R40	MARK, HANDLE FLUSH MOUNT	1	1	
FOP-4-4	19	HZW7-87703-U00	MARK, FLUSH MOUNT	1	1	
FOP-4-4	20	HZW5-90101-U00	SCREW, PAN, 5X16	1	1	
FOP-4-4	21	HZW7-90101-U01	SCREW, TRUSS, 4X12	1	1	
FOP-4-4	22	HZW7-90102-U01	SCREW, PAN, 5X30	4	4	
FOP-4-4	23	HZW7-90103-U01	SCREW, PAN, 6X35	3	3	
FOP-4-4	24	HZW7-90104-U01	SCREW, TAPPING, 6X30	3	3	
FOP-4-4	25	HZW7-90301-U01	NUT, HEX., 6MM	3	3	
FOP-4-4	26	HZW5-90501-U00	WASHER, LOCK, 5MM	4	4	
FOP-4-4	27	HZW7-90502-U00	WASHER, PLAIN, 6MM	3	3	
FOP-4-4	28	HCO-94540-06029	E-RING, 6MM	2	2	

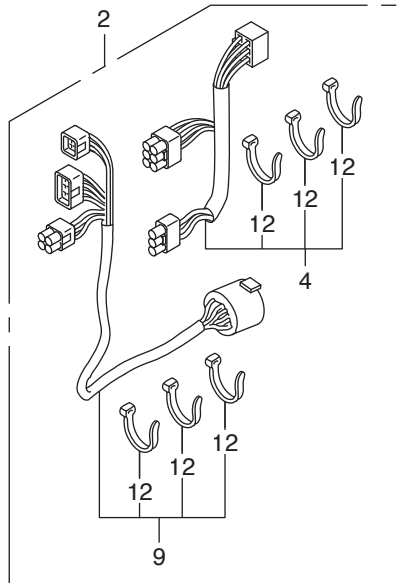
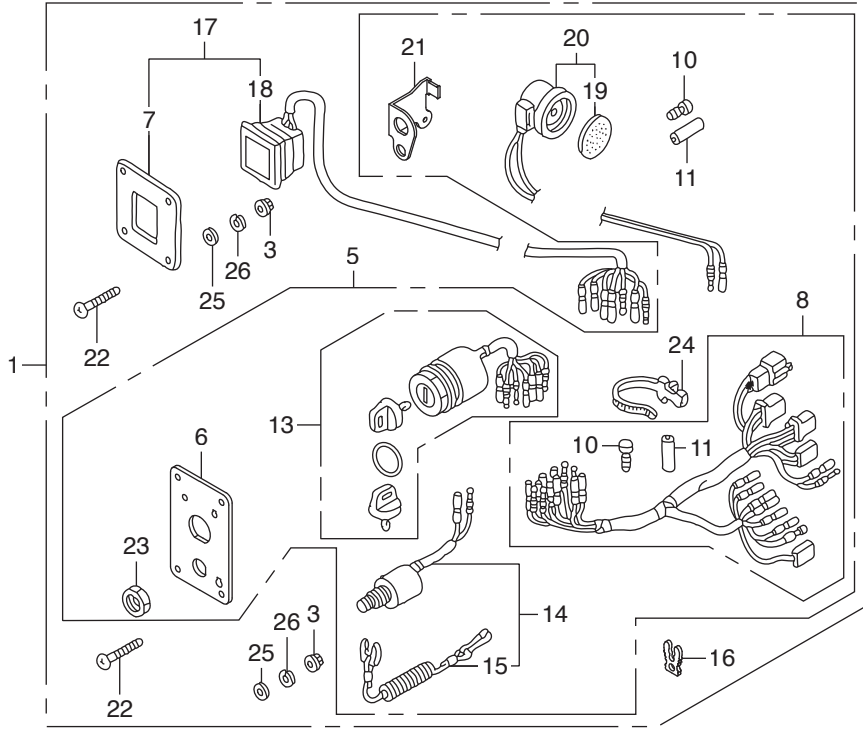

Ref.No.	Part No.	Description	Q' ty		Remarks	
			BET75A	BET90A		
FOP-6	1	HZZ3-06323-R20	PANEL KIT, SWITCH(B)(4-LED)	1	1	
FOP-6	2	HZZ5-06325-600	CABLE SET, PANEL INDICATOR	1	1	(20FT)
FOP-6	2	HZZ5-06325-700	CABLE SET, PANEL INDICATOR	1	1	(25FT)
FOP-6	2	HZZ5-06325-800	CABLE SET, PANEL INDICATOR	1	1	(30FT)
FOP-6	3	HMT8-18334-770	NUT, FLANGE, 5MM	8	8	
FOP-6	4	HZZ5-32185-600	CORD ASSY., INDICATOR(20FT)	1	1	
FOP-6	4	HZZ5-32185-700	CORD ASSY., INDICATOR(25FT)	1	1	
FOP-6	4	HZZ5-32185-800	CORD ASSY., INDICATOR(30FT)	1	1	
FOP-6	5	HZZ3-32341-R31	PANEL ASSY., SWITCH	1	1	
FOP-6	6	HZZ3-32346-R21	PANEL, CONTROL	1	1	
FOP-6	7	HZZ3-32347-R01	PANEL, CONTROL	1	1	
FOP-6	8	HZZ5-32545-000	HARNESS ASSY., SWITCH PANEL	1	1	
FOP-6	9	HZZ5-32580-600	CABLE ASSY., SWITCH PANEL	1	1	(20FT)
FOP-6	9	HZZ5-32580-700	CABLE ASSY., SWITCH PANEL	1	1	(25FT)
FOP-6	9	HZZ5-32580-800	CABLE ASSY., SWITCH PANEL	1	1	(30FT)
FOP-6	10	HZV5-32823-003	PLUG, INNER CONNECTOR	8	8	
FOP-6	11	HZV5-32824-003	PLUG, OUTER CONNECTOR	3	3	
FOP-6	12	H952-32901-770	TIE, CABLE(NATURAL)(2.4X92)	6	6	
FOP-6	13	HZZ3-35100-R11	SWITCH ASSY., COMBINATION	1	1	
FOP-6	14	HZV5-36180-033	SWITCH ASSY., EMERGENCY STOP	1	1	
FOP-6	15	HZV4-36182-651	CORD COMP., EMERGENCY	1	1	
FOP-6	16	HZV4-36187-652	CLIP, EMERGENCY LOCK	1	1	
FOP-6	17	HZZ3-37205-R01	PANEL ASSY., INDICATOR(4-LED)	1	1	
FOP-6	18	HZZ5-37210-762	LAMP ASSY., INDICATION(4-LED)	1	1	
FOP-6	19	H341-38403-672	PLATE, WINKER BUZZER	1	1	
FOP-6	20	HZV5-38410-003	BUZZER COMP., WARNING	1	1	
FOP-6	21	HZZ5-38414-003	BRACKET, BUZZER	1	1	
FOP-6	22	HZW5-90109-000	SCREW, PAN, 5X40	8	8	
FOP-6	23	H921-90302-000	NUT, HEX., 16MM	1	1	

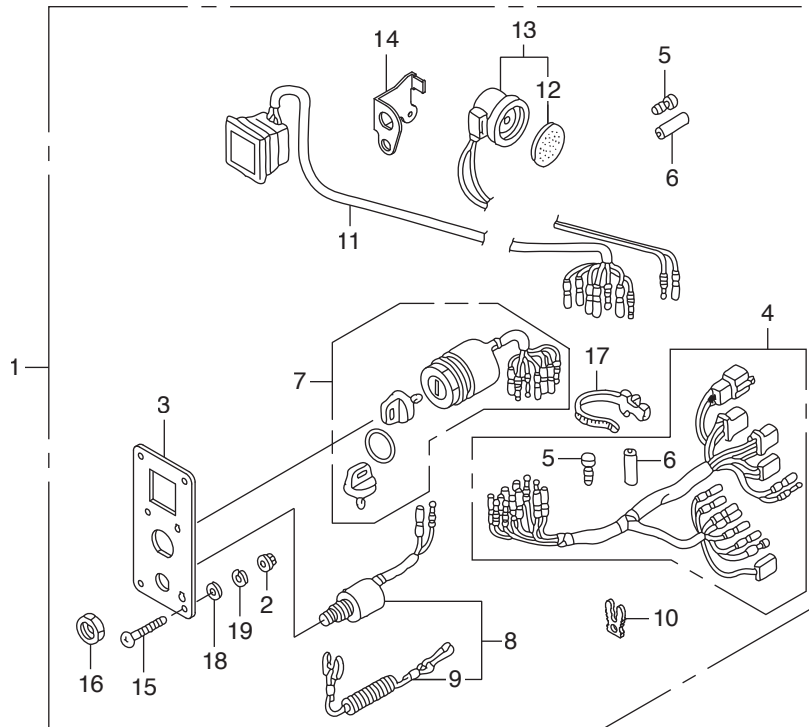

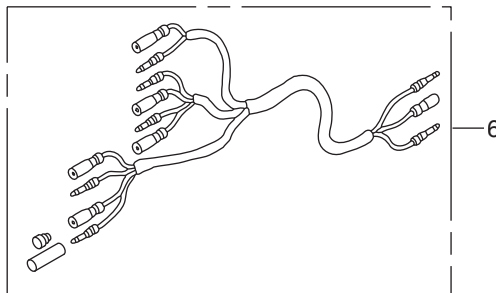
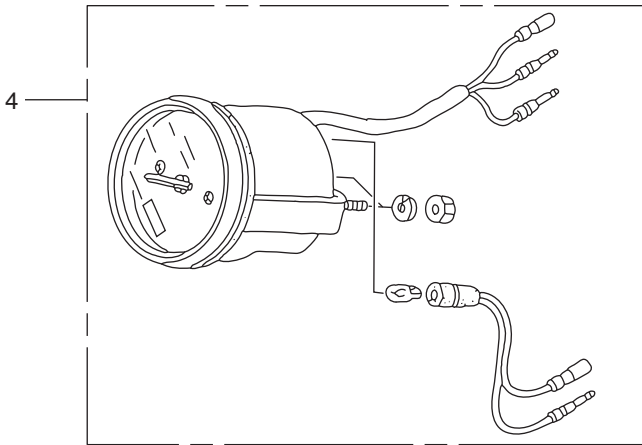
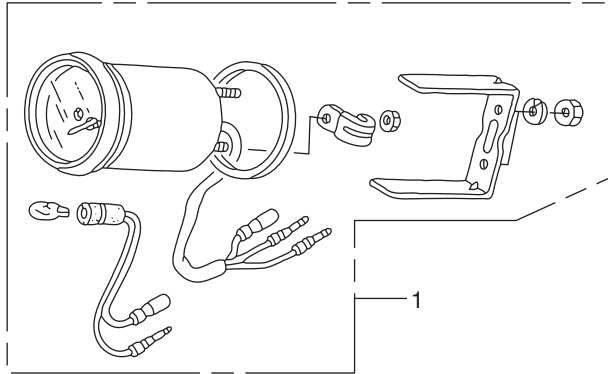

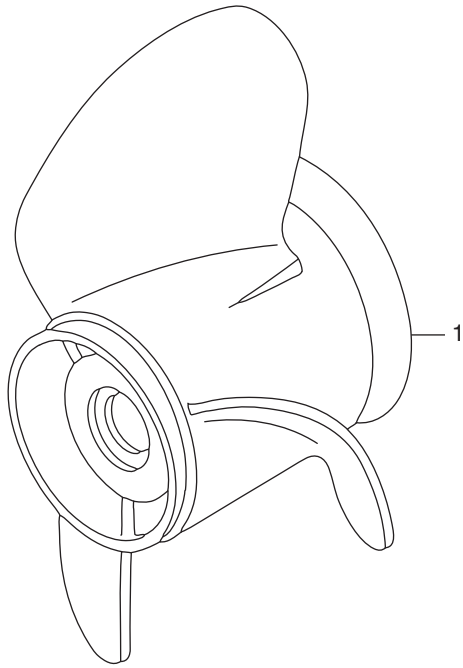

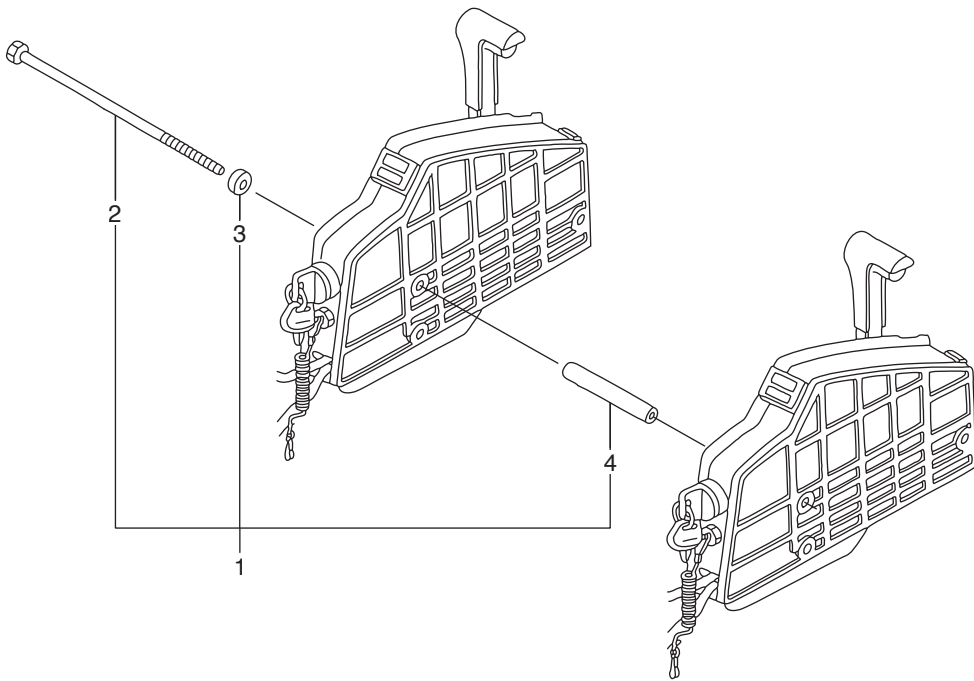

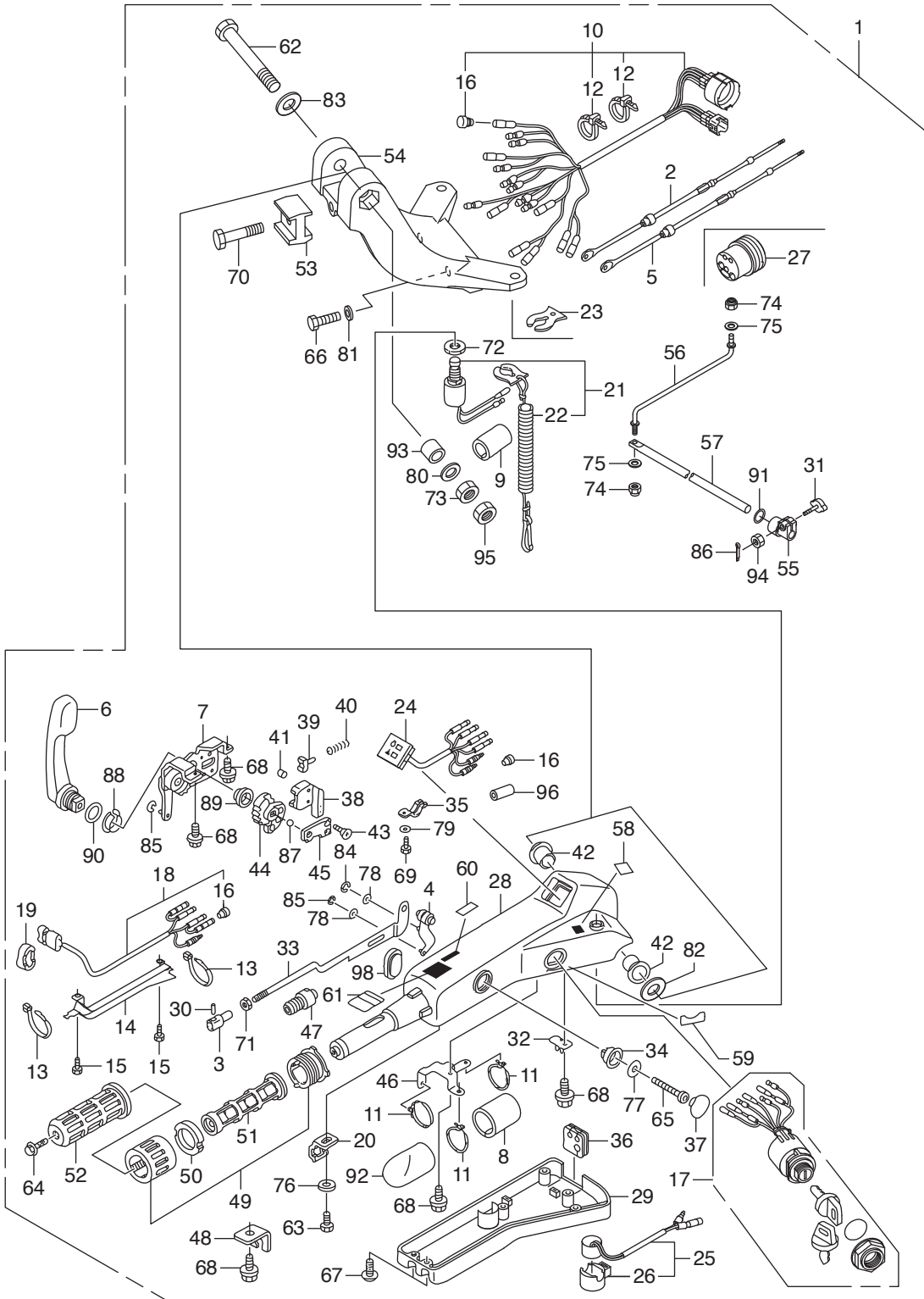

Ref.No.	Part No.	Description	Q' ty		Remarks	
			BET75A	BET90A		
FOP-10	1	HZZ0-06533-R00ZA	HANDLE KIT, STEERING	1	1	*T107* BAY BLUE
FOP-10	2	HZY9-17910-701	CABLE COMP., THROTTLE	1	1	
FOP-10	3	HZW9-17917-000	PIVOT, THROTTLE CABLE	1	1	
FOP-10	4	HZW4-17931-H02	ARM, THROTTLE	1	1	
FOP-10	5	HZY9-24590-701	CABLE COMP., SHIFT	1	1	
FOP-10	6	HZW4-24614-H03	LEVER, SHIFT	1	1	
FOP-10	7	HZW4-24615-H03	FRAME ASSY., SHIFT	1	1	
FOP-10	8	HZW4-32533-H01	TUBE(38.1X40)	1	1	
FOP-10	9	HZY9-32534-A01	TUBE	1	1	
FOP-10	10	HZY9-32538-A01	CABLE ASSY., LONG HANDLE(A)	1	1	
FOP-10	11	HZW4-32543-H01	BAND(CONVEX CV-150)	3	3	
FOP-10	12	HZW4-32544-H01	BAND(CONVEX CV-200)	2	2	
FOP-10	13	HZW4-32547-H01	BAND(CONVEX)	2	2	
FOP-10	14	HZW4-32548-H01	COVER, WIRE	1	1	
FOP-10	15	HZW4-32549-H01	SCREW	2	2	
FOP-10	16	HZV5-32823-003	PLUG, INNER CONNECTOR	14	14	
FOP-10	17	HZZ3-35100-R01	SWITCH ASSY., COMBINATION	1	1	
FOP-10	18	HZW4-35640-H11	SWITCH ASSY., POWER TILT	1	1	
FOP-10	19	HZW4-35643-H02	GROMMET	1	1	
FOP-10	20	HZW4-35645-H02	HOLDER, SWITCH	1	1	
FOP-10	21	HZV5-36180-033	SWITCH ASSY., EMERGENCY STOP	1	1	
FOP-10	22	HZV4-36182-651	CORD COMP., EMERGENCY	1	1	
FOP-10	23	HZV4-36187-652	CLIP, EMERGENCY LOCK	1	1	
FOP-10	24	HZY9-37210-A02	LAMP ASSY., INDICATOR	1	1	
FOP-10	25	HZY9-38400-A00	BUZZER ASSY., WARNING	1	1	
FOP-10	26	HZY9-38402-A00	SUSPENSION, WARNING BUZZER	1	1	
FOP-10	27	HZY9-40105-A00	GROMMET, STEERING HANDLE CABLE	1	1	
FOP-10	28	HZY9-53101-A02ZD	HOUSING	1	1	*T107* BAY BLUE
FOP-10	29	HZY9-53102-A02	COVER, STEERING HANDLE UNDER	1	1	

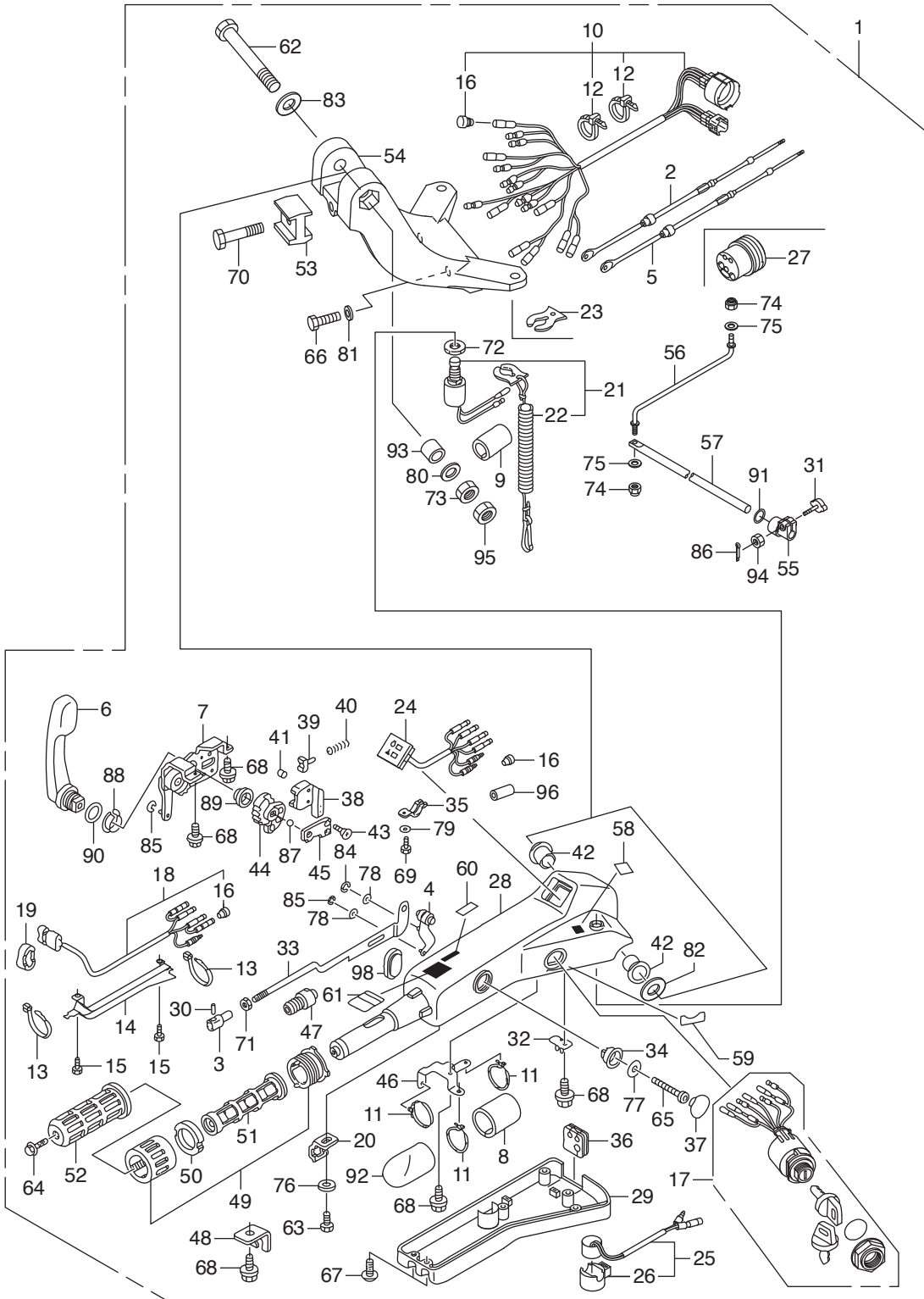

Ref.No.	Part No.	Description	Q' ty		Remarks	
			BET75A	BET90A		
FOP-10	30	HZW9-53103-000	PIN, THROTTLE CABLE	1	1	
FOP-10	31	HZV3-53104-000	BOLT, FRICTION	1	1	
FOP-10	32	HZW4-53104-H02	BRACKET, CABLE	1	1	
FOP-10	33	HZY9-53105-A01	PLATE ASSY., LOCK	1	1	
FOP-10	34	HZW4-53106-H01	STOPPER	1	1	
FOP-10	35	HZW4-53107-H02	PLATE, GUIDE	1	1	
FOP-10	36	HZY9-53108-A00	GROMMET	1	1	
FOP-10	37	HZW4-53109-H02	CAP	1	1	
FOP-10	38	HZW4-53112-H02	GUIDE, SPRING	1	1	
FOP-10	39	HZW4-53113-H01	ACTUATOR	1	1	
FOP-10	40	HZW4-53114-H01	SPRING, COIL	1	1	
FOP-10	41	HZW4-53116-H01	ROLLER	1	1	
FOP-10	42	HZW4-53116-H11	BUSH, STEERING HANDLE	2	2	
FOP-10	43	HZW4-53117-H01	SCREW(M5X14)	4	4	
FOP-10	44	HZW4-53118-H03	GEAR, SHIFT	1	1	
FOP-10	45	HZW4-53119-H02	PLATE, BALL GUIDE	1	1	
FOP-10	46	HZW4-53121-H02	BRACKET	1	1	
FOP-10	47	HZW4-53122-H01	ROD, GROMMET	1	1	
FOP-10	48	HZW4-53123-H01	CLAMP, BRACKET	1	1	
FOP-10	49	HZW9-53130-000	GRIP ASSY., THROTTLE FRICTION	1	1	
FOP-10	50	HZW9-53133-000	PAD, THROTTLE FRICTION	1	1	
FOP-10	51	HZW4-53141-H00	PIPE, GRIP	1	1	
FOP-10	52	HZW9-53165-000	RUBBER, GRIP	1	1	
FOP-10	53	HZY9-53232-A00	BLOCK, HEIGHT ADJUSTER	1	1	
FOP-10	54	HZY9-53233-A00ZD	BRACKET B, STEERING	1	1	*T107* BAY BLUE
FOP-10	55	HZW1-53236-700	BLOCK, STEERING FRICTION	1	1	
FOP-10	56	HZW1-53238-700	ROD, STEERING FRICTION	1	1	
FOP-10	57	HZW1-53239-701	SHAFT, STEERING FRICTION	1	1	
FOP-10	58	HZW6-87124-U80	MARK, EMERGENCY SWITCH	1	1	INDICATION(EU)

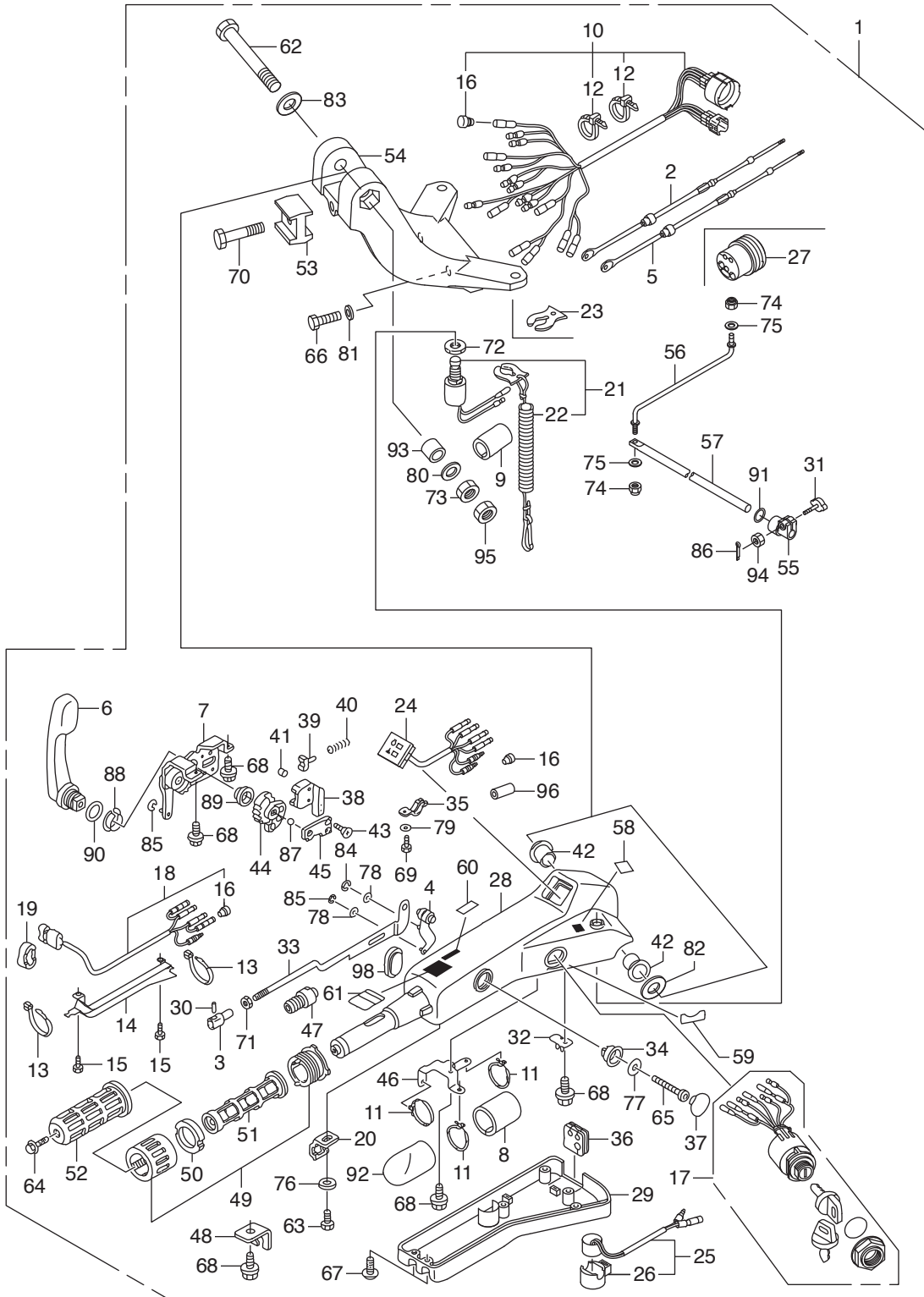

Ref.No.	Part No.	Description	Q' ty		Remarks	
			BET75A	BET90A		
FOP-10	59	HZZ0-87125-R00	MARK, START	1	1	
FOP-10	60	HZW9-87511-000	MARK, CHANGE	1	1	
FOP-10	61	HZW9-87532-640	MARK, THROTTLE(ENGLISH)	1	1	
FOP-10	62	HZW4-90101-H00	BOLT, HEX., 12X80	1	1	
FOP-10	63	HZW4-90102-H01	BOLT(M5X8)	1	1	
FOP-10	64	HZW9-90102-000	BOLT, FLANGE, 6X12	1	1	
FOP-10	65	HZW4-90103-H02	BOLT(M8X50)	1	1	
FOP-10	66	HZY3-90103-000	BOLT, HEX., 10X32	2	2	
FOP-10	67	HZW4-90104-H01	BOLT(M5X12)	6	6	
FOP-10	68	HZW4-90105-H02	BOLT(M6X12)	5	5	
FOP-10	69	HZW4-90106-H01	BOLT(M5X12)	3	3	
FOP-10	70	HHW1-90118-671	BOLT, FLANGE, 8X28	1	1	
FOP-10	71	HZW4-90301-H01	NUT, HEX., 5MM	1	1	
FOP-10	72	H921-90302-000	NUT, HEX., 16MM	1	1	
FOP-10	73	HZW4-90303-H00	NUT, HEX., 12MM	1	1	
FOP-10	74	HZV4-90305-000	NUT, SELF-LOCK, 8MM	2	2	
FOP-10	75	HZW1-90401-000	WASHER, PLAIN, 8MM	2	2	
FOP-10	76	HZW4-90501-H01	WASHER, 5MM	1	1	
FOP-10	77	HZW4-90502-H02	WASHER, 8MM	1	1	
FOP-10	78	HZW4-90503-H01	WASHER, 10MM	2	2	
FOP-10	79	HZW4-90504-H01	WASHER, 5MM	3	3	
FOP-10	80	HZV1-90506-000	WASHER, WAVE, 14MM	1	1	
FOP-10	81	HZV4-90514-000	WASHER, 10MM	2	2	
FOP-10	82	HZV5-90552-000	WASHER, PLAIN, 12MM	1	1	
FOP-10	83	HZV5-90559-000	WASHER, PLAIN, 12MM	1	1	
FOP-10	84	HZW4-90651-H01	E-RING	1	1	
FOP-10	85	HZW4-90652-H01	E-RING	2	2	
FOP-10	86	HZV1-90759-000	PIN, SPLIT, 2.0	1	1	
FOP-10	87	HZY9-90951-A01	BALL, STEEL	1	1	

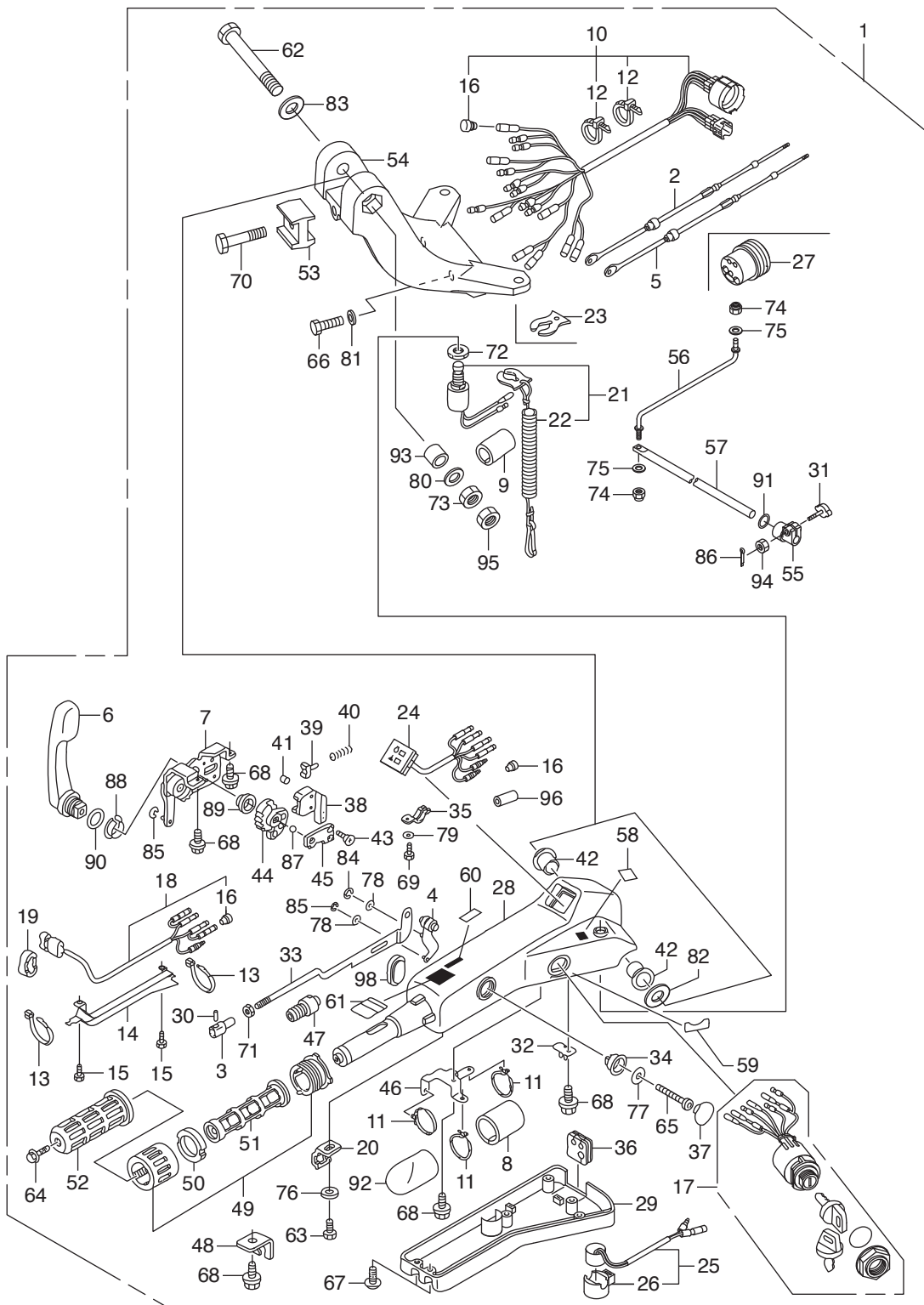

2

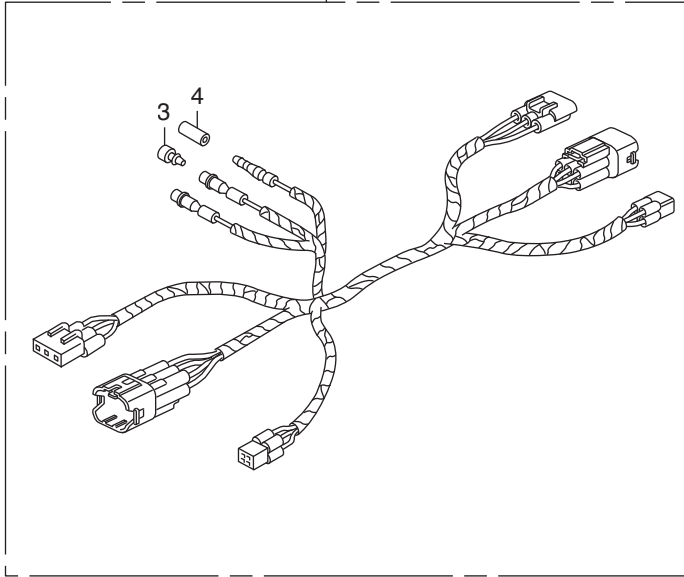

1

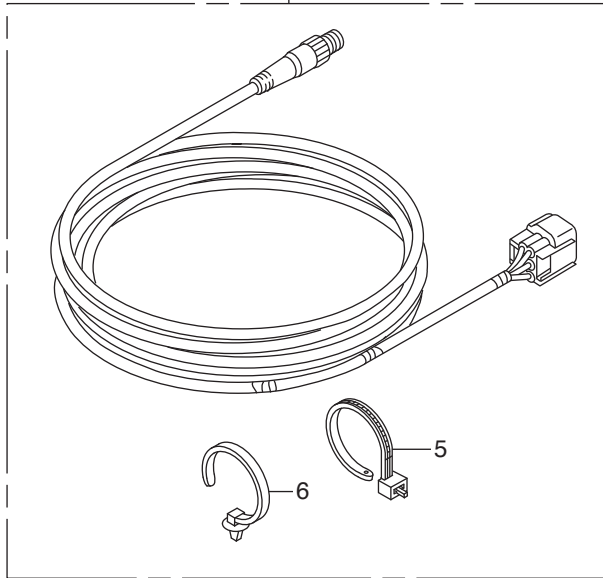

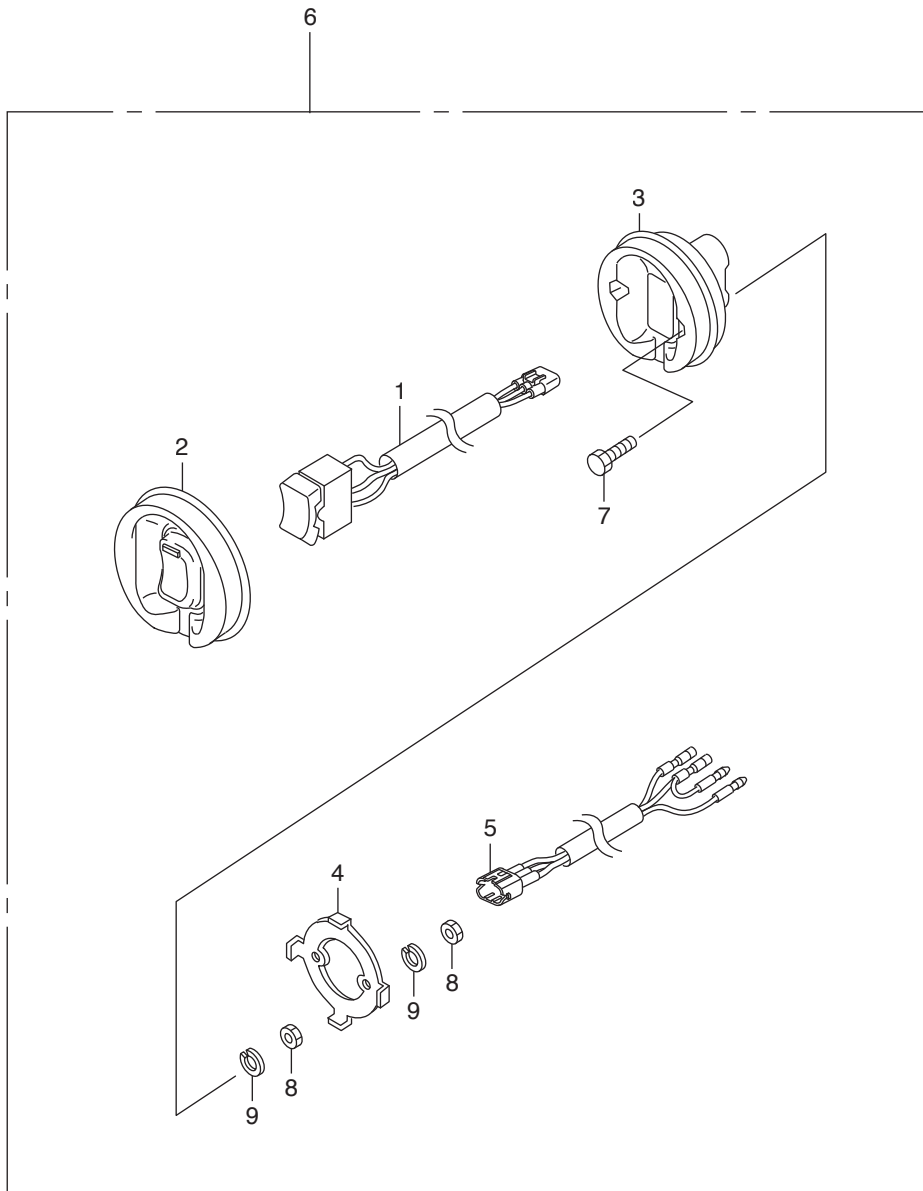

INDEX

<A>			
ACTUATOR	FOP-10-39	BOLT(M5X8)	FOP-10-63
ARM ASSY, ROCKER	E-9-6	BOLT(M6X12)	FOP-10-68
ARM ASSY, SHIFT LINK	F-15-1-18	BOLT(M8X50)	FOP-10-65
ARM ASSY, THROTTLE LINK	F-15-1-21	BOLT, 1/4-28UNF	F-10-28
ARM COMP, EX. ROCKER(A)	E-9-8	BOLT, 12MM	E-7-13
ARM COMP, EX. ROCKER(B)	E-9-9	BOLT, 3/8-24UNF	F-10-30
ARM COMP, IN. VALVE ROCKER	E-9-7	BOLT, CONNECTING ROD	E-7-4
ARM COMP, LINK JOINT	F-15-19	BOLT, DRAIN PLUG	E-6-12
ARM COMP, SHIFT LINK	F-15-15	BOLT, DRAIN PLUG	F-3-10-16
ARM, NEUTRAL LOCK	FOP-4-4-5	BOLT, FLANGE, 10X25	F-10-36
ARM, SHIFT	F-2-11	BOLT, FLANGE, 10X35	E-21-22
ARM, THROTTLE	F-2-7	BOLT, FLANGE, 10X40	F-3-26
ARM, THROTTLE	FOP-10-4	BOLT, FLANGE, 10X75	E-21-19
ARMATURE COMP.	F-11-6	BOLT, FLANGE, 6X10	E-14-14
		BOLT, FLANGE, 6X10	F-7-6
BAG, TOOL, 200MM	F-13-14	BOLT, FLANGE, 6X11	F-2-26
BALL, STEEL	E-21-6	BOLT, FLANGE, 6X12	E-6-9
BALL, STEEL	F-15-1-46	BOLT, FLANGE, 6X12	F-2-27
BALL, STEEL	FOP-10-87	BOLT, FLANGE, 6X12	F-3-28
BALL, STEEL, #11(11/32)	F-5-28	BOLT, FLANGE, 6X12	F-3-30-16
BALL, STEEL, #7(7/32)	F-5-27	BOLT, FLANGE, 6X12	F-4-20
BAND	E-18-20-45	BOLT, FLANGE, 6X12	F-7-5
BAND(BLACK 3.5X140)	F-3-4	BOLT, FLANGE, 6X12	F-7-10-22
BAND(BLACK 3.5X140)	F-15-41	BOLT, FLANGE, 6X12	FOP-10-64
BAND(CONVEX CV-150)	FOP-10-11	BOLT, FLANGE, 6X14	E-3-34
BAND(CONVEX CV-200)	FOP-10-12	BOLT, FLANGE, 6X14	E-9-30
BAND(CONVEX)	FOP-10-13	BOLT, FLANGE, 6X14	E-18-20-49
BAND, AIR FLOW	E-15-6	BOLT, FLANGE, 6X14	F-7-10-25
BAND, CABLE(B)	F-15-1-11	BOLT, FLANGE, 6X14(CT200)	E-9-10-7
BAND, CORD	F-7-10-2	BOLT, FLANGE, 6X14(CT200)	E-18-20
BAND, SELF LOCK	F-15-65	BOLT, FLANGE, 6X14(CT200)	E-18-10-17
BAND, UNDER CASE GROMMET	F-3-9	BOLT, FLANGE, 6X14(CT200)	F-2-23
BAND, WIRE	F-3-3	BOLT, FLANGE, 6X14(CT200)	F-7-4
BAND, WIRE HARNESS	F-7-7	BOLT, FLANGE, 6X14(CT200)	F-7-18
BAND, WIRE HARNESS(NATURAL)	FOP-6-24	BOLT, FLANGE, 6X14(CT200)	F-7-10-21
BAND, WIRE HARNESS(NATURAL)	FOP-6-1-17	BOLT, FLANGE, 6X16	E-2-29
BASE	FOP-4-4-15	BOLT, FLANGE, 6X16	E-6-18
BEARING	FOP-10-88	BOLT, FLANGE, 6X16	E-9-10-9
BEARING	FOP-10-89	BOLT, FLANGE, 6X16	F-2-25
BEARING A, CONNECTING ROD	E-7-6	BOLT, FLANGE, 6X16	F-10-38
BEARING B, CONNECTING ROD	E-7-6	BOLT, FLANGE, 6X18(CT200)	E-5-10
BEARING B, MAIN LOWER(BLACK)	E-7-10	BOLT, FLANGE, 6X18(CT200)	F-2-24
BEARING B, MAIN UPPER(BLACK)	E-7-8	BOLT, FLANGE, 6X20	E-2-30
BEARING C, CONNECTING ROD	E-7-6	BOLT, FLANGE, 6X20	F-3-30-17
BEARING C, MAIN LOWER(BROWN)	E-7-10	BOLT, FLANGE, 6X20	F-7-10-24
BEARING C, MAIN UPPER(BROWN)	E-7-8	BOLT, FLANGE, 6X20	F-10-31
BEARING D, CONNECTING ROD	E-7-6	BOLT, FLANGE, 6X22	E-1-4
BEARING D, MAIN LOWER(GREEN)	E-7-10	BOLT, FLANGE, 6X22	E-2-32
BEARING D, MAIN UPPER(GREEN)	E-7-8	BOLT, FLANGE, 6X22	E-3-22
BEARING E, CONNECTING ROD	E-7-6	BOLT, FLANGE, 6X22	E-9-10-11
BEARING E, MAIN LOWER(YELLOW)	E-7-10	BOLT, FLANGE, 6X22	E-18-19
BEARING E, MAIN UPPER(YELLOW)	E-7-8	BOLT, FLANGE, 6X22	F-3-30-14
BEARING F, CONNECTING ROD	E-7-6	BOLT, FLANGE, 6X23	F-10-27
BEARING F, MAIN LOWER(PINK)	E-7-10	BOLT, FLANGE, 6X25	E-3-20
BEARING F, MAIN UPPER(PINK)	E-7-8	BOLT, FLANGE, 6X25	E-18-21
BEARING G, CONNECTING ROD(RED)	E-7-6	BOLT, FLANGE, 6X25	E-18-20-48
BEARING G, MAIN LOWER(RED)	E-7-10	BOLT, FLANGE, 6X25	E-20-2
BEARING G, MAIN UPPER(RED)	E-7-8	BOLT, FLANGE, 6X25(SUS-D)	F-10-37
BEARING H, MAIN LOWER(WHITE)	E-7-10	BOLT, FLANGE, 6X28	E-9-31
BEARING H, MAIN UPPER(WHITE)	E-7-8	BOLT, FLANGE, 6X28	E-9-10-8
BEARING, BALL(28X38X3)	F-5-21	BOLT, FLANGE, 6X32	E-3-23
BEARING, NEEDLE	F-4-29	BOLT, FLANGE, 6X32	E-19-5
BEARING, NEEDLE, 30X37X26	F-5-19	BOLT, FLANGE, 6X35	E-2-31
BEARING, RADIAL BALL, 6208	F-5-26	BOLT, FLANGE, 6X35	F-3-10-22
BEARING, TAPER ROLLER	F-4-30	BOLT, FLANGE, 6X40	E-9-10-12
BEARING, TAPERED ROLLER	F-5-20	BOLT, FLANGE, 6X55	E-2-34
BLOCK ASSY, CYLINDER	E-3-4	BOLT, FLANGE, 6X55	F-8-26
BLOCK, HEIGHT ADJUSTER	FOP-10-53	BOLT, FLANGE, 8X100	E-6-8
BLOCK, NEUTRAL LOCK	F-15-7	BOLT, FLANGE, 8X100	E-6-19
BLOCK, STEERING FRICTION	FOP-10-55	BOLT, FLANGE, 8X110	E-2-28
BLOCK, THROTTLE FRICTION	F-15-29	BOLT, FLANGE, 8X120	E-6-20
BODY	E-18-20-4	BOLT, FLANGE, 8X18	F-7-10-28
BODY, TROLLING CONTROL SWITCH	FOP-12-3	BOLT, FLANGE, 8X20	E-3-21
BOLT	F-15-1-37	BOLT, FLANGE, 8X25	F-10-35
BOLT A, THROUGH	E-21-18	BOLT, FLANGE, 8X28	FOP-10-70
BOLT KIT, SIDE REMOTE CONTROL	FOP-9-1	BOLT, FLANGE, 8X35	E-3-24
BOLT(M5X12)	FOP-10-67	BOLT, FLANGE, 8X35	E-6-10
BOLT(M5X12)	FOP-10-69	BOLT, FLANGE, 8X35	E-14-15
		BOLT, FLANGE, 8X35	F-15-50
		BOLT, FLANGE, 8X40	E-5-12
		BOLT, FLANGE, 8X45	E-3-25
		BOLT, FLANGE, 8X45	E-6-11
		BOLT, FLANGE, 8X45	E-14-16
		BOLT, FLANGE, 8X60	E-5-11
		BOLT, FLANGE, 8X60	E-15-18
		BOLT, FLANGE, 8X95	E-2-27
		BOLT, FLANGE(SH)6X20	F-8-31
		BOLT, FLANGE(SH)6X25	E-15-19
		BOLT, FRICTION	F-15-30
		BOLT, FRICTION	FOP-10-31
		BOLT, HEX	F-11-30
		BOLT, HEX, 10X235	F-10-32
		BOLT, HEX, 10X32	FOP-10-66
		BOLT, HEX, 10X80	F-3-10-14
		BOLT, HEX, 12X119	F-10-34
		BOLT, HEX, 12X186	F-3-27
		BOLT, HEX, 12X186	F-10-29
		BOLT, HEX, 12X80	FOP-10-62
		BOLT, HEX, 4X20	FOP-12-7
		BOLT, HEX, 5X16	F-15-70
		BOLT, HEX, 6X14	F-10-33
		BOLT, HEX, 8X25	F-3-10-15
		BOLT, HEX, 8X55	F-4-19
		BOLT, HEX, 8X55	FOP-3-10
		BOLT, OIL CHECK	F-3-10-12
		BOLT, RECESSED	F-11-27
		BOLT, ROCKER ARM SHAFT	E-9-25
		BOLT, RR. BRACKET	F-8-28
		BOLT, SEALING, 18MM	E-5-7
		BOLT, SEALING, 20MM	E-2-7
		BOLT, SEALING, 24MM	E-3-1
		BOLT, SEALING, 6MM	E-18-20-46
		BOLT, SOCKET(A)	F-11-28
		BOLT, SOCKET(B)	F-11-29
		BOLT, SOCKET, 6X16	F-3-10-20
		BOLT, SPECIAL, 6X17	F-8-27
		BOLT, SPECIAL, 6X220	FOP-9-2
		BOLT, SPECIAL, 6X31	E-9-10-10
		BOLT, SPECIAL, 6X37	F-8-30
		BOLT, STUD(10X164)	F-3-10-19
		BOLT, STUD(10X202)	F-3-10-18
		BOLT, STUD, 6X40	E-14-12
		BOLT, STUD, 8X28	F-3-30-15
		BOLT, STUD, 8X32	E-2-33
		BOLT, TDC PULSER PLATE	E-9-4
		BOLT, TENSIONER PIVOT	E-9-24
		BOLT, TORX(M6X20)	E-20-10-11
		BOLT-WASHER, 10X105	E-3-17
		BOLT-WASHER, 10X30	E-9-26
		BOLT-WASHER, 10X40	F-3-10-17
		BOLT-WASHER, 10X40	F-5-13
		BOLT-WASHER, 14X36	E-19-4
		BOLT-WASHER, 5X30	E-15-17
		BOLT-WASHER, 5X9	F-7-20
		BOLT-WASHER, 6X22	F-8-25
		BOLT-WASHER, 6X27	F-3-31
		BOLT-WASHER, 6X27(CT200)	E-15-15
		BOLT-WASHER, 6X27(CT200)	E-20-10-10
		BOLT-WASHER, 6X27(CT200)	F-7-17
		BOLT-WASHER, 6X27(CT200)	F-7-10-42
		BOLT-WASHER, 6X27(CT200)	F-8-24
		BOLT-WASHER, 6X95	F-3-29
		BOLT-WASHER, 8X30	F-3-30
		BOLT-WASHER, 8X35	E-14-13
		BOLT-WASHER, 8X35	E-18-20-47
		BOLT-WASHER, 9X155	E-2-26
		BOX ASSY, REMOTE CONTROL	F-15-1-1
		BOX ASSY, REMOTE CONTROL(EU)	F-15-2
		BOX KIT, REMOTE CONTROL	FOP-4-1
		BOX KIT, REMOTE CONTROL	FOP-4-2-1
		BOX KIT, REMOTE CONTROL	FOP-4-4-1
		BRACKET	FOP-10-46
		BRACKET A, COUPLER	F-7-2
		BRACKET A, HARNESS CLIP	E-9-10-2
		BRACKET ASSY	F-11-5
		BRACKET B, HARNESS CLIP	E-18-10-15
		BRACKET B, STEERING	FOP-10-54
		BRACKET C, COUPLER	F-7-3

BRACKET C, HARNESS CLIP	E-9-10-3	CASE, SWIVEL	F-10-12	COLLAR, ORIFICE	F-11-44
BRACKET D, HARNESS CLIP	E-2-22	CHAIN(132L)	E-9-5	COLLAR, P.T.T. RELAY	F-7-10-36
BRACKET E, HARNESS CLIP	E-9-10-4	CIRCLIP, EXTERNAL	F-15-1-44	COLLAR, SLIDING PLATE	F-15-17
BRACKET, BUZZER	FOP-6-21	CIRCLIP, EXTERNAL, 12	F-2-35	COLLAR, SPLASH PLATE	F-10-59
BRACKET, BUZZER	FOP-6-1-14	CIRCLIP, EXTERNAL, 14MM	F-5-25	COLLAR, STEERING ROD	F-10-60
BRACKET, CABLE	FOP-10-32	CIRCLIP, EXTERNAL, 39MM	F-10-54	CONTROL UNIT, ELECTRONIC	E-20-10-9
BRACKET, COUPLER	F-7-11	CIRCLIP, INTERNAL	F-11-32	CONTROL UNIT, ELECTRONIC	E-20-10-9
BRACKET, ELECTRONIC CONTROL	E-20-10-4	CIRCLIP, INTERNAL, 40	F-3-10-28	CORD ASSY., INDICATOR(20FT)	FOP-6-4
BRACKET, FR.	E-21-10	CLAMP	F-6-5	CORD ASSY., INDICATOR(25FT)	FOP-6-4
BRACKET, FR. UNDER COVER	F-3-10	CLAMP	F-6-8	CORD ASSY., INDICATOR(30FT)	FOP-6-4
BRACKET, FUEL TUBE CLAMP	E-18-10	CLAMP A, FUEL TUBE	E-18-13	CORD COMP., EMERGENCY	F-15-43
BRACKET, FUSE BOX	F-7-10-12	CLAMP B, FUEL TUBE	E-2-14	CORD COMP., EMERGENCY	F-15-1-29
BRACKET, L. STERN	F-10-16	CLAMP B, FUEL TUBE	E-15-4	CORD COMP., EMERGENCY	FOP-6-15
BRACKET, LINK JOINT	F-15-20	CLAMP B, FUEL TUBE	E-18-14	CORD COMP., EMERGENCY	FOP-6-1-9
BRACKET, NEUTRAL SWITCH	F-2-20	CLAMP B, FUEL TUBE	E-18-20-38	CORD COMP., EMERGENCY	FOP-10-22
BRACKET, R. STERN	F-10-15	CLAMP D, FUEL TUBE	E-18-20-39	COTTER, VALVE(FUJI VALVE)	E-9-23
BRACKET, RELAY	F-7-10-16	CLAMP, BRACKET	FOP-10-48	COVER ASSY.	FOP-4-4-11
BRACKET, REMOTE CONTROL	FOP-4-12	CLAMP, CHECK VALVE	E-18-20-24	COVER ASSY., A.C. GENERATOR	F-7-30-1
BRACKET, REMOTE CONTROL	FOP-4-2-13	CLAMP, HARNESS	F-15-10	COVER ASSY., ENGINE	F-8-13
BRACKET, RR.	E-21-11	CLAMP, OXYGEN SENSOR	E-18-18	COVER ASSY., FUSE(70A)	F-7-14
BRACKET, SENSOR CORD	E-15-10	CLAMP, POWER TILT CORD	F-15-32	COVER ASSY., OIL PATH	E-2-12
BRACKET, SHIFT LINK	F-2-16	CLAMP, TUBE	E-18-10-14	COVER B, GEAR CASE	F-3-10-6
BRACKET, TILTING	F-10-21	CLAMP, TUBE(7.5-11.5)(BLACK)	E-18-10-13	COVER COMP.	E-18-20-5
BRACKET, TROLLING CONTROL	FOP-12-4	CLAMP, TUBE(D10.5)	F-3-30-18	COVER COMP., CYLINDER HEAD	E-1-1
BRACKET, UNDER COVER	F-8-10	CLAMP, TUBE(D10.7)	E-18-20-51	COVER COMP., L. ENGINE UNDER	F-8-19
BREAKER ASSY.	F-11-1	CLAMP, TUBE(D29)	E-1-5	COVER COMP., R. ENGINE UNDER	F-8-18
BRUSH ASSY.	F-11-2	CLAMPER, CORD	F-7-10-8	COVER, DUAL GRIP	FOP-4-2-8
BRUSH SET	E-21-7	CLIP B1, TUBE	F-8-36	COVER, FLUSH VALVE	F-3-30-4
BUFFER, PLATE	E-18-10-4	CLIP(14MM)	F-3-37	COVER, GRIP	F-15-1-6
BUSH	F-15-1-23	CLIP, 10.7MM	F-8-35	COVER, GRIP	FOP-4-4-4
BUSH A, COVER LOCK	F-2-22	CLIP, 7MM	F-3-38	COVER, IMPELLER	F-4-4
BUSH COMP., VERTICAL SHAFT	F-3-10-3	CLIP, BRAKE PIPE(A)	F-2-21	COVER, IMPELLER	FOP-3-6
BUSH, LOWER CYLINDER	F-11-23	CLIP, COUPLER HOLDER(B)	F-7-10-10	COVER, L. GRIP	FOP-4-5
BUSH, MOTOR CODE	F-3-21	CLIP, EMERGENCY LOCK	F-15-44	COVER, L. GRIP	FOP-4-2-6
BUSH, MOTOR CODE	F-11-18	CLIP, EMERGENCY LOCK	FOP-6-16	COVER, LOCK ARM	FOP-4-4-6
BUSH, STEERING HANDLE	FOP-10-42	CLIP, EMERGENCY LOCK	FOP-6-1-10	COVER, OIL PUMP	E-5-2
BUSH, SWIVEL CASE	F-10-14	CLIP, EMERGENCY LOCK	FOP-10-23	COVER, PLUG MAINTENANCE	F-8-17
BUSH, SWIVEL CASE	F-11-10	CLIP, HARNESS	E-2-35	COVER, PUMP(A)	E-18-20-27
BUSH, TILT ARM	F-10-20	CLIP, HARNESS BAND(BLACK)	E-2-38	COVER, PUMP(B)	E-18-20-26
BUSHING	F-15-1-8	CLIP, HARNESS BAND(BLACK)	F-2-42	COVER, RELIEF VALVE	F-3-30-8
BUTTON, THROTTLE	F-15-1-9	CLIP, HARNESS BAND(BLACK)	F-7-8	COVER, REMOTE CONTROL CABLE	F-2-6
BUTTON, THROTTLE	FOP-4-9	CLIP, HARNESS BAND(BLACK)	FOP-11-6	COVER, SEPARATE FRONT	F-8-9
BUTTON, THROTTLE	FOP-4-2-10	CLIP, HARNESS BAND(BROWN)	F-7-9	COVER, STARTER TERMINAL	F-7-10-5
BUTTON, THROTTLE	FOP-4-4-8	CLIP, HARNESS BAND(NATURAL)	E-19-6	COVER, STEERING HANDLE UNDER	FOP-10-29
BUZZER ASSY., WARNING	FOP-10-25	CLIP, INJECTOR	E-14-2	COVER, THERMOSTAT	E-2-16
BUZZER COMP., WARNING	F-15-47	CLIP, SENSOR HOSE	E-18-10-16	COVER, THERMOSTAT	E-3-10
BUZZER COMP., WARNING	FOP-6-20	CLIP, TUBE	E-18-20-23	COVER, UPPER MOUNT	F-10-10
BUZZER COMP., WARNING	FOP-6-1-13	CLIP, TUBE	F-3-30-25	COVER, WATER JACKET	E-2-18
<C>		CLIP, TUBE(B10)	F-3-30-19	COVER, WATER JACKET	E-18-20-10
CABLE ASSY., LONG HANDLE(A)	FOP-10-10	CLIP, TUBE(B12)	E-18-22	COVER, WIRE	FOP-10-14
CABLE ASSY., REMOTE CONTROL(B)	F-15-35	CLIP, TUBE(B12)	E-18-10-18	CRANKSHAFT COMP.	E-7-7
CABLE ASSY., STARTER	F-7-10-4	CLIP, TUBE, 3.5	F-7-10-19	CUP, WATER SEPARATOR	E-18-10-3
CABLE ASSY., SWITCH PANEL	FOP-6-9	CLIP, WIRE HARNESS	F-7-20-3	<D>	
CABLE ASSY., SWITCH PANEL	FOP-6-9	CLIP, WIRE HARNESS	F-10-55	DOWEL PIN, 12X14	E-3-27
CABLE ASSY., SWITCH PANEL	FOP-6-9	CLIP, WIRE HARNESS(6.3MM)	F-15-67	DOWEL PIN, 14X20	E-2-41
CABLE COMP., SHIFT	FOP-10-5	CLIP, WIRE HARNESS, 25MM	F-7-10-33	DOWEL PIN, 6X10	E-6-14
CABLE COMP., THROTTLE	FOP-10-2	CLUTCH COMP., OVERRUNNING	E-21-2	DOWEL PIN, 6X10	E-6-17
CABLE SET, PANEL INDICATOR	FOP-6-2	COIL ASSY., PLUG TOP	E-20-1	DOWEL PIN, 6X10	F-3-40
CABLE SET, PANEL INDICATOR	FOP-6-2	COLLAR, 8.5X14.5	E-14-22	DOWEL PIN, 6X10	F-3-10-29
CABLE SET, PANEL INDICATOR	FOP-6-2	COLLAR, 8.5X14.5	E-18-20-53	DOWEL PIN, 6X10	F-3-10-29
CAMSHAFT COMP.	E-9-1	COLLAR, C.D.I. UNIT CASE	E-15-24	DOWEL PIN, 6X10	F-4-28
CAMSHAFT COMP.	E-9-1	COLLAR, C.D.I. UNIT CASE	F-3-41	DRIVER 1, PLUS SCREW(NO.2)	F-13-16
CAP	FOP-10-37	COLLAR, C.D.I. UNIT CASE	F-7-23	<E>	
CAP ASSY., OIL FILLER	E-3-6	COLLAR, C.D.I. UNIT CASE	F-7-10-35	E-RING	FOP-10-84
CAP COMP., OIL TANK	F-11-26	COLLAR, C.D.I. UNIT CASE	F-7-20-4	E-RING	FOP-10-85
CAP, GRIP	FOP-4-7	COLLAR, C.D.I. UNIT CASE	F-7-30-3	E-RING, 10MM	F-4-37
CAP, GRIP	FOP-4-2-9	COLLAR, C.D.I. UNIT CASE	F-8-40	E-RING, 12MM	F-2-46
CAP, HANDLE	F-15-6	COLLAR, DISTANCE	F-4-36	E-RING, 15MM	F-11-45
CAP, L. SIDE COVER	F-3-24	COLLAR, DISTANCE	FOP-3-14	E-RING, 3MM	F-15-79
CAP, SWITCH	FOP-4-8	COLLAR, DISTANCE(6.5X11X27)	F-8-39	E-RING, 4MM	F-2-44
CAP, WATER JOINT	F-8-5	COLLAR, DISTANCE(A)	FOP-9-3	E-RING, 4MM	F-3-43
CARTRIDGE, OIL FILTER	E-3-5	COLLAR, DISTANCE(B)	FOP-9-4	E-RING, 4MM	F-15-80
CASE ASSY., GEAR(L)	F-3-20-1	COLLAR, DISTANCE, 12.2X23X16	FOP-10-93	E-RING, 6MM	F-2-45
CASE ASSY., GEAR(XL)	F-3-20-1	COLLAR, DISTANCE, 6.2X7.5	F-8-42	E-RING, 6MM	FOP-4-36
CASE ASSY., OIL	E-6-1	COLLAR, DISTANCE, 6.5X11X7.5	F-3-30-2	E-RING, 6MM	FOP-4-2-41
CASE COMP., CHAIN	E-9-10-1	COLLAR, DISTANCE, 6.5X11X7.5	F-7-10-1	E-RING, 6MM	FOP-4-4-28
CASE COMP., MOUNT	F-3-30-12	COLLAR, DISTANCE, 6.5X9X3	F-3-10-31	E-RING, 7MM	F-15-81
CASE COMP., SILENCER	E-15-7	COLLAR, DISTANCE, 6.5X9X5	F-8-41	EXTENSION, OIL FILLER	E-3-8
CASE COMP., SILENCER	E-15-7	COLLAR, DISTANCE, 6X10X43.5	F-15-69	<F>	
CASE, ELECTRONIC PARTS	F-7-20-1	COLLAR, FR. BRACKET	F-3-42	FILTER ASSY., SPOOL VALVE	E-2-11
CASE, EXTENSION	F-3-11	COLLAR, LINK JOINT	F-15-68	FILTER B.	F-11-16
CASE, GEAR	F-3-10-4	COLLAR, LOWER CYLINDER	F-10-26	FLOAT SET	E-18-20-2
CASE, PUMP	E-18-20-25	COLLAR, LOWER MOUNTING	F-3-17	FLYWHEEL COMP.	E-7-12

FRAME ASSY., REMOTE CONTROL	F-15-1-10	HOLDER, SEAL	F-2-17	MARK, FR. EMBLEM(TOHATSU)	F-12-18
FRAME ASSY., SHIFT	FOP-10-7	HOLDER, SHIFT ROD	F-4-14	MARK, HANDLE FLUSH MOUNT	FOP-4-4-18
FRAME COMP., MOUNTING	F-10-6	HOLDER, SWITCH	FOP-10-20	MARK, L. SIDE STRIPE	F-12-17
FUSE(70A)	F-7-13	HOSE COMP., FUEL	E-18-8	MARK, R. SIDE STRIPE	F-12-6
FUSE, MINI(10A)	F-7-24	HOSE, PRESSURE REGULATOR	E-18-20-42	MARK, REMOTE CONTROL(A)(PANEL)	F-15-1-31
FUSE, MINI(15A)	F-7-25	HOUSING	FOP-10-28	MARK, REMOTE CONTROL(B)	F-15-1-32
FUSE, MINI(30A)	F-7-26	HOUSING ASSY., INNER	F-15-1-22	MARK, REMOTE CONTROL(C)	F-15-1-32
<G>		HOUSING ASSY., L. INNER	FOP-4-3	MARK, REMOTE CONTROL(DUAL)	FOP-4-2-24
GASKET B, IMPELLER	F-4-5	HOUSING ASSY., R. INNER	FOP-4-2-3	MARK, REMOTE CONTROL(SINGLE)	FOP-4-21
GASKET B, IMPELLER	FOP-3-7	HOUSING ASSY., R. INNER	FOP-4-2-4	MARK, RR.(BFT75)	F-12-2
GASKET COMP., CYLINDER HEAD	E-2-8	HOUSING ASSY., R. INNER	FOP-4-4-2	MARK, RR.(BFT90)	F-12-3
GASKET, MOUNT CASE	E-6-7	HOUSING ASSY., REMOTE CONTROL	F-15-1-7	MARK, START	FOP-10-59
GASKET, WATER PUMP	F-4-7	HOUSING COMP., REMOTE CONTROL	F-15-11	MARK, THROTTLE(ENGLISH)	FOP-10-61
GASKET, WATER PUMP	FOP-3-8	HOUSING COMP., REMOTE CONTROL	F-15-12	METAL COMP., ANODE	F-3-10-11
GAUGE COMP., OIL LEVEL	E-6-4	HOUSING COMP., REMOTE CONTROL	FOP-4-13	METAL KIT, ANODE	F-10-1
GEAR ASSY., INTERNAL	E-21-24	HOUSING COMP., REMOTE CONTROL	FOP-4-2-14	METAL, ANODE	E-2-1
GEAR ASSY., PLANETARY	E-21-3	HOUSING, IMPELLER	F-4-2	METER LEAD WIRE	FOP-7-6
GEAR COMP., FR. BEVEL	F-5-8	HOUSING, IMPELLER	FOP-3-4	MOTION COMP., LOST	E-2-9
GEAR, PINION(12T)	F-4-18	HOUSING, LEAD	FOP-4-14	MOTOR ASSY., POWER TILT	F-11-4
GEAR, RR. BEVEL	F-5-9	HOUSING, LEAD	FOP-4-2-15	MOTOR ASSY., STARTER	E-21-1
GEAR, SHIFT	FOP-10-44	HOUSING, LOWER CENTER MOUNTING	F-3-19	MOUNT COMP., LOWER RUBBER	F-3-16
GENERATOR ASSY., A.C.	E-19-1	HOUSING, LOWER MOUNTING	F-3-15	MOUNT COMP., UPPER RUBBER	F-10-7
GRIP ASSY., THROTTLE FRICTION	FOP-10-49	HOUSING, REMOTE CONTROL BOX(B)	F-15-1-12	<N>	
GRIP, REMOTE CONTROL HANDLE	F-15-5	HOUSING, REMOTE CONTROL BOX(C)	F-15-13	NIPPLE, GREASE	F-10-36
GRIP, REMOTE CONTROL HANDLE	F-15-1-4	HOUSING, REMOTE CONTROL BOX(C)	F-15-1-14	NIPPLE, SENSOR	F-3-13
GRIP, REMOTE CONTROL HANDLE	FOP-4-6	HOUSING, WATER PUMP	F-4-6	NIPPLE, SENSOR	F-3-45
GRIP, REMOTE CONTROL HANDLE	FOP-4-2-7	<I>		NUT(1/4X20)	F-15-1-41
GRIP, SCREW DRIVER	F-13-6	IMPELLER, PUMP	F-4-1	NUT, ADJUSTER ROD	F-10-42
GROMMET	F-15-1-15	IMPELLER, PUMP	FOP-3-3	NUT, CASTLE, 18MM	F-5-14
GROMMET	FOP-10-19	INJECTOR ASSY., FUEL	E-14-1	NUT, CLIP	F-8-32
GROMMET	FOP-10-36	INSULATOR	E-18-20-29	NUT, FLANGE CAP, 8MM	E-3-26
GROMMET, 1WAY	E-6-16	INSULATOR COMP.	E-18-20-28	NUT, FLANGE, 10MM	F-10-43
GROMMET, ELECTRONIC PARTS CASE	E-15-9	INSULATOR, FUEL PIPE	E-14-4	NUT, FLANGE, 10MM	F-10-63
GROMMET, ELECTRONIC PARTS CASE	F-7-20-2	<J>		NUT, FLANGE, 12MM	F-3-35
GROMMET, ENGINE COVER	F-8-21	JOINT A, BREATHER	F-3-2	NUT, FLANGE, 12MM	F-10-39
GROMMET, EXTENSION CASE	F-4-15	JOINT ASSY (INLET)	F-6-2	NUT, FLANGE, 5MM	FOP-6-3
GROMMET, FUEL HOSE	E-18-9	JOINT ASSY (OUTLET)	F-6-3	NUT, FLANGE, 5MM	FOP-6-1-2
GROMMET, GEAR CASE	F-3-10-5	JOINT SET	E-18-20-7	NUT, FLANGE, 6MM	E-14-18
GROMMET, GEAR CASE	F-3-10-7	JOINT, DRIVE	F-11-14	NUT, FLANGE, 8MM	E-14-17
GROMMET, POWER TILT SWITCH	FOP-10-98	JOINT, FUEL FEED HOSE	E-18-10-1	NUT, HEX., 12MM	F-10-61
GROMMET, RELAY	F-7-16	JOINT, FUEL PIPE	E-14-6	NUT, HEX., 12MM	FOP-10-73
GROMMET, RELAY BRACKET	F-7-10-17	JOINT, FUEL PIPE	E-18-20-37	NUT, HEX., 12MM	FOP-10-95
GROMMET, REMOTE CONTROL CABLE	F-3-7	JOINT, FUEL TUBE	E-15-5	NUT, HEX., 16MM	F-4-22
GROMMET, SILENCER	E-15-8	JOINT, WATER HOSE	F-8-3	NUT, HEX., 16MM	F-8-33
GROMMET, STEERING HANDLE CABLE	FOP-10-27	JOINT, WATER MOUTH	F-13-17	NUT, HEX., 16MM	F-15-54
GROMMET, TA SENSOR	E-15-14	JOINT, WATER TUBE	F-3-30-10	NUT, HEX., 16MM	FOP-6-23
GROMMET, UNDER CASE	E-9-10-6	<K>		NUT, HEX., 16MM	FOP-6-1-16
GROMMET, UNDER CASE	F-3-6	KEY, SPECIAL	E-7-14	NUT, HEX., 16MM	FOP-10-72
GROMMET, UNDER CASE	F-7-30-2	KEY, WOODRUFF	F-4-27	NUT, HEX., 20MM	F-2-28
GROMMET, UNDER CASE	F-8-8	KEY, WOODRUFF	FOP-3-12	NUT, HEX., 4MM	FOP-12-8
GROMMET, UNDER CASE(C)	F-3-8	KIT, CABLE(NMEA)(6FT)	FOP-11-1	NUT, HEX., 5MM	F-2-43
GROMMET, VAPOR SEPARATOR	E-14-5	KNOB, RECOIL STARTER	F-13-1	NUT, HEX., 5MM	F-15-78
GROMMET, VAPOR SEPARATOR	E-18-20-32	<L>		NUT, HEX., 5MM	FOP-4-29
GROMMET, WATER CHECK	F-8-22	LABEL, CAUTION OIL(ENGLISH)	F-12-13	NUT, HEX., 5MM	FOP-4-35
GROMMET, WATER TUBE	E-6-5	LABEL, CAUTION OPERATOR	F-12-15	NUT, HEX., 5MM	FOP-4-2-33
GUIDE COMP., CAM CHAIN	E-9-12	LABEL, FUSE	F-12-1	NUT, HEX., 5MM	FOP-4-2-34
GUIDE COMP., ROD	F-11-15	LAMP ASSY., INDICATION	F-15-45	NUT, HEX., 5MM	FOP-4-2-40
GUIDE, EX. VALVE(OS)	E-2-3	LAMP ASSY., INDICATION(4-LED)	FOP-6-18	NUT, HEX., 5MM	FOP-10-71
GUIDE, IN. VALVE(OS)	E-2-2	LAMP ASSY., INDICATION(4-LED)	FOP-6-1-11	NUT, HEX., 6MM	F-15-55
GUIDE, SPRING	FOP-10-38	LAMP ASSY., INDICATOR	FOP-10-24	NUT, HEX., 6MM	F-15-77
<H>		LEVER SET	E-21-17	NUT, HEX., 6MM	FOP-4-4-25
HANDLE KIT, STEERING	FOP-10-1	LEVER, FASTENER	F-3-22	NUT, HEX., 6MM	FOP-10-94
HANDLE, REMOTE CONTROL	F-15-3	LEVER, FASTENER	F-8-15	NUT, LOCK, 64MM	F-4-21
HANDLE, REMOTE CONTROL	F-15-1-2	LEVER, HANDLE LOCK	F-15-4	NUT, SELF-LOCK(25X2.0)	F-10-41
HANDLE, REMOTE CONTROL	FOP-4-4	LEVER, HANDLE LOCK	F-15-1-3	NUT, SELF-LOCK(3/8-24UNF)	F-10-44
HANDLE, REMOTE CONTROL	FOP-4-2-5	LEVER, IDLE	F-15-23	NUT, SELF-LOCK(7/8-14UNF)	F-10-40
HANDLE, REMOTE CONTROL	FOP-4-4-3	LEVER, SHIFT	FOP-10-6	NUT, SELF-LOCK, 10MM	F-3-10-24
HANGER, ENGINE	E-3-3	LIFTER, FUEL PUMP	E-2-13	NUT, SELF-LOCK, 5MM	F-3-10-23
HARNESS ASSY., MAIN WIRE	F-7-1	LINE COMP., FUEL	E-14-3	NUT, SELF-LOCK, 6MM	F-3-10-21
HARNESS ASSY., MAIN WIRE	F-7-1	LINER, PUMP	F-4-3	NUT, SELF-LOCK, 8MM	FOP-10-74
HARNESS ASSY., POWER TRIM-TILT	F-15-1-27	LINER, PUMP	FOP-3-5	NUT, TAPPET ADJUSTING	E-9-27
HARNESS ASSY., REMOTE CONTROL	FOP-11-2	LINER, SWIVEL CASE	F-10-13	NUT, TAPPET ADJUSTING	E-9-28
HARNESS ASSY., SWITCH PANEL	FOP-6-8	LINK, THROTTLE	F-2-3	NUT, WATER MOUTH	F-8-2
HARNESS ASSY., SWITCH PANEL	FOP-6-1-4	LINKAGE, PIVOT	F-2-1	NUT-WASHER, 8MM	F-7-22
HARNESS COMP.	E-18-20-44	LOW PERMEATION HOSE L=1600	F-6-7	NUT-WASHER, 8MM	F-7-10-30
HARNESS, TROLLING CONTROL	FOP-12-5	LOW PERMEATION HOSE L=700	F-6-6	<O>	
HEAD COMP., CYLINDER	E-2-5	<M>		OIL SEAL	F-11-33
HOLDER	E-18-20-9	MANIFOLD COMP., INLET	E-14-9	OIL SEAL, 39.5X52X6(ARAI)	F-10-57
HOLDER COMP., BRUSH	E-21-9	MARK, CHANGE	FOP-10-60	OIL SEAL, 40X55X7(NOK)	E-9-10-13
HOLDER COMP., STARTER CABLE	F-7-10-6	MARK, EMERGENCY START(ENGLISH)	F-12-16	OIL SEAL, 80X98X10(ARAI)	E-3-28
HOLDER, NEUTRAL LOCK	FOP-4-4-14	MARK, EMERGENCY SWITCH	FOP-10-58	O-RING	E-15-12
HOLDER, OIL FILTER	E-3-19	MARK, FAST IDLE	F-15-49	O-RING	E-18-10-11
HOLDER, PROPELLER SHAFT	F-5-12	MARK, FLUSH MOUNT	FOP-4-4-19	O-RING	E-18-20-11

O-RING.....	E-18-20-12	PIN, SPRING, 2.5X20.....	F-10-62	PUMP UNIT, FUEL.....	E-18-20-34
O-RING.....	E-18-20-14	PIN, THROTTLE CABLE.....	FOP-10-30	PUMP UNIT, FUEL(A).....	E-18-20-3
O-RING.....	E-18-20-15	PIN, UPPER CYLINDER.....	F-11-24	PUMP UNIT, FUEL(B).....	E-18-20-8
O-RING.....	E-18-20-16	PIPE COMP., OIL LEVEL.....	F-3-30-1	<R>	
O-RING.....	F-4-33	PIPE, BREATHER.....	E-15-1	RECEIVER, THRUST.....	F-10-25
O-RING SET, 3.5X31.7.....	F-11-41	PIPE, GRIP.....	FOP-10-51	RECTIFIER ASSY., REGULATOR.....	E-2-20
O-RING, 1.8X69.6.....	F-11-35	PIPE, HARNESS GUIDE.....	F-15-33	REGULATOR ASSY., PRESSURE.....	E-18-20-35
O-RING, 1.8X7.7.....	F-11-37	PIPE, OIL.....	E-3-7	RELAY ASSY., MAIN.....	F-7-10-18
O-RING, 1.9X11.....	F-11-38	PISTON COMP., FREE.....	F-11-20	RELAY ASSY., POWER TILT.....	F-7-10-14
O-RING, 11.5X3.5.....	F-3-30-22	PISTON(0.25).....	E-7-2	RETAINER.....	F-15-1-13
O-RING, 13X1.5(ARAI).....	E-3-32	PISTON(STD.).....	E-7-2	RETAINER, VALVE SPRING.....	E-9-21
O-RING, 15.54X2.26.....	F-10-58	PIVOT, SHIFT.....	F-2-13	RING.....	E-18-20-30
O-RING, 15.54X2.26.....	FOP-10-91	PIVOT, SHIFT.....	F-15-18	RING SET, PISTON(0.25).....	E-7-1
O-RING, 15.5X2.7.....	E-6-15	PIVOT, SHIFT SLIDE.....	F-2-14	RING SET, PISTON(STD.).....	E-7-1
O-RING, 15X1.9.....	E-2-37	PIVOT, THROTTLE CABLE.....	FOP-10-3	RING, BACK UP.....	F-11-17
O-RING, 15X1.9.....	E-9-10-14	PLATE.....	E-18-10-12	RING, CROSS PIN.....	F-5-3
O-RING, 16MM.....	F-3-30-21	PLATE ASSY., LOCK.....	FOP-10-33	RING, STOPPER.....	F-4-13
O-RING, 18.1X3.6.....	E-3-29	PLATE COMP., SLIDING.....	F-15-16	RING, WATER TUBE SEAL.....	F-4-9
O-RING, 2.0X70.5.....	F-11-34	PLATE COMP., SPLASH.....	F-10-19	RING, WATER TUBE SEAL.....	FOP-3-9
O-RING, 20.6X1.9.....	FOP-10-90	PLATE COMP., THROTTLE.....	F-2-4	ROD A COMP., SHIFT(L).....	F-4-12
O-RING, 27X2(ARAI).....	F-2-41	PLATE KIT, SPLASH.....	F-10-2	ROD A COMP., SHIFT(XL).....	F-4-12
O-RING, 28.3X2.4(NOK).....	E-3-33	PLATE, BALL GUIDE.....	FOP-10-45	ROD COMP., CONNECTING.....	E-7-5
O-RING, 3.5X35.7.....	F-11-39	PLATE, CABLE CLAMP.....	FOP-4-11	ROD COMP., PISTON.....	F-11-19
O-RING, 3.5X38.7.....	F-11-36	PLATE, CABLE CLAMP.....	FOP-4-2-12	ROD COMP., PISTON(B).....	F-11-13
O-RING, 3.5X41.7.....	F-11-40	PLATE, DWELL.....	FOP-4-15	ROD COMP., SHIFT(L).....	F-4-10
O-RING, 31.2X2.4.....	E-18-23	PLATE, DWELL.....	FOP-4-2-16	ROD COMP., THROTTLE.....	F-2-2
O-RING, 58.5X3.5.....	F-4-35	PLATE, DWELL.....	FOP-4-4-10	ROD, ADJUSTING.....	F-10-17
O-RING, 59.4X3.1.....	E-21-23	PLATE, GUIDE.....	FOP-10-35	ROD, GROMMET.....	FOP-10-47
O-RING, 6.5X1.5.....	E-3-30	PLATE, HANDLE.....	FOP-4-10	ROD, STEERING.....	F-10-24
O-RING, 6.9X1.45.....	F-3-10-30	PLATE, HANDLE.....	FOP-4-2-11	ROD, STEERING FRICTION.....	FOP-10-56
O-RING, 7.45X3.61(NOK).....	E-14-21	PLATE, LEVER SETTING.....	F-15-9	ROLLER.....	FOP-10-41
O-RING, 7.47X3.6.....	E-14-20	PLATE, LOCK.....	F-2-15	ROLLER, 3X12.8.....	F-5-22
O-RING, 7.8X1.9(ARAI).....	E-14-19	PLATE, REMOTE CONTROL.....	F-15-48	ROLLER, 5X17.8.....	E-5-16
O-RING, 7.8X1.9(ARAI).....	E-18-20-52	PLATE, REMOTE CONTROL CABLE.....	F-2-5	ROLLER, CLICK.....	F-15-66
O-RING, 9.5X1.9.....	E-2-36	PLATE, RUBBER SETTING.....	F-3-10-1	ROLLER, SHIFT CLICK.....	F-15-1-47
O-RING, 9.5X1.9.....	E-3-31	PLATE, SHIFT.....	F-5-7	ROPE, RECOIL STARTER.....	F-13-2
O-RING, 94X4.1.....	F-5-24	PLATE, SHIFT PIVOT.....	F-2-12	ROTOR.....	E-19-2
O-RING, OIL PUMP.....	E-5-15	PLATE, SPEED SENSOR TUBE.....	F-3-20	ROTOR COMP.....	E-21-5
O-RING, PRESSURE REGULATOR.....	E-18-20-36	PLATE, SPRING SETTING.....	F-15-24	ROTOR, INNER.....	E-5-8
O-RING, PUMP COVER.....	E-5-14	PLATE, STEERING.....	F-10-23	ROTOR, OUTER.....	E-5-9
O-RING, THERMOSTAT COVER.....	E-2-17	PLATE, TDC PULSER.....	E-9-3	RUBBER, FENDER MOUNTING.....	F-8-12
O-RING, THERMOSTAT COVER.....	E-3-11	PLATE, WATER TUBE.....	E-6-6	RUBBER, GRIP.....	FOP-10-52
O-RING, THERMOSTAT COVER.....	F-3-30-11	PLATE, WINKER BUZZER.....	F-15-46	RUBBER, RING.....	E-2-42
O-RING, WATER PUMP.....	F-4-34	PLATE, WINKER BUZZER.....	FOP-6-19	RUBBER, RING.....	E-3-36
O-RING, WATER PUMP.....	FOP-3-13	PLATE, WINKER BUZZER.....	FOP-6-1-12	RUBBER, SEAT SIDE.....	F-8-20
<P>		PLUG, INNER CONNECTOR.....	F-15-36	RUBBER, TROLLING CONTROL.....	FOP-12-2
PACKING.....	E-18-20-13	PLUG, INNER CONNECTOR.....	FOP-6-10	RUBBER, UPPER MOUNT STOPPER.....	F-10-8
PACKING.....	F-11-43	PLUG, INNER CONNECTOR.....	FOP-6-1-5	<S>	
PACKING, DUAL.....	FOP-4-2-19	PLUG, INNER CONNECTOR.....	FOP-10-16	SCREEN COMP., FUEL STRAINER.....	E-18-20-40
PACKING, ELECTRONIC AIR.....	E-14-11	PLUG, INNER CONNECTOR.....	FOP-11-3	SCREEN, L. WATER.....	F-3-10-9
PACKING, EX. WATER JACKET.....	E-2-19	PLUG, OUTER CONNECTOR.....	F-15-37	SCREEN, R. WATER.....	F-3-10-8
PACKING, FLASH VALVE.....	F-3-30-9	PLUG, OUTER CONNECTOR.....	FOP-6-11	SCREEN.....	FOP-10-15
PACKING, FUSE BOX COVER.....	F-7-15	PLUG, OUTER CONNECTOR.....	FOP-6-1-6	SCREW A.....	F-15-1-33
PACKING, HEAD COVER.....	E-1-2	PLUG, OUTER CONNECTOR.....	FOP-10-96	SCREW B.....	F-15-1-34
PACKING, INTAKE MANIFOLD.....	E-14-7	PLUG, OUTER CONNECTOR.....	FOP-11-4	SCREW C.....	F-15-1-35
PACKING, OIL PAN.....	E-6-2	PLUG, SPARK(IZFR6K-11E).....	E-20-3	SCREW SET.....	E-15-2
PACKING, REGULATOR.....	E-2-21	PLUG, SPARK(ZFR6K-9E).....	E-20-3	SCREW SET, DRAIN.....	E-18-20-6
PACKING, SINGLE.....	FOP-4-18	PORT, IDLE EXHAUST.....	F-8-1	SCREW(10-32X3/8).....	F-15-1-39
PACKING, THROTTLE BODY.....	E-14-8	PRIMER BULB.....	F-6-4	SCREW(10-32X5/8).....	F-15-1-40
PAD, THROTTLE FRICTION.....	FOP-10-50	PRIMER BULB ASSY.....	F-6-1	SCREW(8-32X3/8).....	F-15-1-38
PANEL ASSY., INDICATOR(4-LED).....	FOP-6-17	PROPELLER COMP., THREE BLADES.....	FOP-8-1	SCREW(M5X14).....	FOP-10-43
PANEL ASSY., SWITCH.....	FOP-6-5	PROPELLER COMP., THREE BLADES.....	FOP-8-1	SCREW, 6X95.....	F-15-53
PANEL ASSY., TROLLING CONTROL.....	FOP-12-6	PROPELLER COMP., THREE BLADES.....	FOP-8-1	SCREW, FLAT, 5X12.....	F-15-52
PANEL KIT, SWITCH(4-LED).....	FOP-6-1-1	PROPELLER COMP., THREE BLADES.....	FOP-8-1	SCREW, FLAT, 5X55.....	F-3-10-13
PANEL KIT, SWITCH(B)(4-LED).....	FOP-6-1	PROPELLER COMP., THREE BLADES.....	FOP-8-1	SCREW, FRICTION.....	F-15-1-36
PANEL, CONTROL.....	FOP-6-6	PROPELLER COMP., THREE BLADES.....	FOP-8-1	SCREW, PAN.....	E-18-20-19
PANEL, CONTROL.....	FOP-6-7	PROPELLER COMP., THREE BLADES.....	FOP-8-1	SCREW, PAN, 4X10.....	FOP-4-26
PANEL, CONTROL.....	FOP-6-1-3	PROPELLER COMP., THREE BLADES.....	FOP-8-1	SCREW, PAN, 4X10.....	FOP-4-2-29
PIN A, DOWEL, 7X12.....	E-9-29	PROPELLER COMP., THREE BLADES.....	FOP-8-1	SCREW, PAN, 5X10.....	F-15-71
PIN, 5X44.5.....	F-3-39	PROPELLER COMP., THREE BLADES.....	FOP-8-1	SCREW, PAN, 5X10.....	FOP-4-23
PIN, 5X59.....	F-8-38	PROPELLER COMP., THREE BLADES.....	FOP-8-1	SCREW, PAN, 5X10.....	FOP-4-2-26
PIN, 6X6.....	F-15-64	PROPELLER COMP., THREE BLADES.....	FOP-8-1	SCREW, PAN, 5X12.....	E-18-10-8
PIN, GEARSHIFT.....	F-15-1-45	PROPELLER COMP., THREE BLADES.....	FOP-8-1	SCREW, PAN, 5X16.....	FOP-4-22
PIN, LINK.....	F-2-37	PROPELLER COMP., THREE BLADES.....	FOP-8-1	SCREW, PAN, 5X16.....	FOP-4-2-25
PIN, LINK.....	F-2-39	PROPELLER COMP., THREE BLADES.....	FOP-8-1	SCREW, PAN, 5X16.....	FOP-4-4-20
PIN, LOCK, 6MM.....	F-15-63	PROPELLER COMP., THREE BLADES.....	FOP-8-1	SCREW, PAN, 5X18.....	E-15-16
PIN, PISTON.....	E-7-3	PULLER, MINI FUSE(SUMITOMO).....	F-13-4	SCREW, PAN, 5X18.....	FOP-4-25
PIN, SHIFT LINK.....	F-2-38	PUMP ASSY KIT, FUEL.....	E-18-1	SCREW, PAN, 5X18.....	FOP-4-2-28
PIN, SHIFTER, 8X47.....	F-5-2	PUMP ASSY.....	F-11-12	SCREW, PAN, 5X20.....	FOP-4-24
PIN, SNAP, 6MM.....	F-2-36	PUMP ASSY., FUEL.....	E-18-7	SCREW, PAN, 5X20.....	FOP-4-2-27
PIN, SPLIT, 2.0.....	FOP-10-86	PUMP ASSY., OIL.....	E-5-1	SCREW, PAN, 5X30.....	FOP-4-4-22
PIN, SPLIT, 4.0.....	F-5-18	PUMP KIT, IMPELLER.....	FOP-3-1	SCREW, PAN, 5X40.....	FOP-4-28
PIN, SPRING, 2.0X12.....	F-8-37	PUMP KIT, IMPELLER.....	FOP-3-2	SCREW, PAN, 5X40.....	FOP-4-2-31

SCREW, PAN, 5X40.....	FOP-6-22	SLIDER COMP., SHIFT	F-5-4	TERMINAL, CABLE	FOP-4-4-12
SCREW, PAN, 5X40.....	FOP-6-1-15	SLIDER, SHIFT.....	F-5-5	THERMOSTAT ASSY.....	E-2-15
SCREW, PAN, 5X55.....	FOP-4-2-32	SLINGER, OIL	F-4-17	THERMOSTAT ASSY.....	E-3-9
SCREW, PAN, 5X65.....	FOP-4-4-34	SPACER KIT, REMOTE CONTROL BOX ..	FOP-4-2	THROTTLE BODY ASSY.....	E-15-3
SCREW, PAN, 5X65.....	FOP-4-2-39	SPACER KIT, REMOTE CONTROL BOX ..	FOP-4-2-2	TIE, CABLE.....	FOP-11-5
SCREW, PAN, 5X8.....	E-21-21	SPACER, CABLE CLAMP	F-15-34	TIE, CABLE(NATURAL)(2.4X92).....	F-15-38
SCREW, PAN, 6X10.....	F-15-51	SPACER, CABLE CLAMP	FOP-4-17	TIE, CABLE(NATURAL)(2.4X92).....	FOP-6-12
SCREW, PAN, 6X18.....	E-2-39	SPACER, CABLE CLAMP	FOP-4-2-18	T-JOINT	E-18-16
SCREW, PAN, 6X18.....	FOP-4-27	SPACER, CABLE CLAMP	FOP-4-4-13	TRIM METER ASSY (BLACK).....	FOP-7-1
SCREW, PAN, 6X18.....	FOP-4-2-30	SPACER, CLICK SPRING.....	F-15-28	TRIM-TILT ASSY., POWER.....	F-11-11
SCREW, PAN, 6X22.....	E-21-20	SPACER, NEUTRAL SWITCH.....	F-15-31	TRIM-TILT ASSY., POWER.....	FOP-10-9
SCREW, PAN, 6X35.....	FOP-4-4-23	SPACER, REMOTE CONTROL BOX	F-15-27	TUBE A, AIR VENT.....	E-18-4
SCREW, PAN, 6X8.....	F-3-32	SPANNER, 8X10.....	F-13-15	TUBE A, BREATHER.....	E-15-21
SCREW, PAN, 6X8.....	F-3-33	SPRING COMP., CLICK.....	F-2-9	TUBE A, CHECK VALVE	E-18-2
SCREW, PAN, 6X8.....	F-11-31	SPRING COMP., CLICK.....	F-10-3	TUBE A, WATER.....	E-18-20-43
SCREW, RIVET, 5X10.....	F-3-34	SPRING, ACCELERATOR WHEEL.....	F-15-22	TUBE B, AIR VENT.....	E-18-5
SCREW, RIVET, 5X10.....	F-8-29	SPRING, CHOKE RETURN	F-15-26	TUBE B, BREATHER.....	E-15-22
SCREW, TAPPET ADJUSTING.....	E-9-18	SPRING, CLICK ASSIST.....	F-2-10	TUBE B, CHECK VALVE	E-18-3
SCREW, TAPPING, 5X10.....	F-15-73	SPRING, CLICK ASSIST.....	F-10-4	TUBE B, WATER.....	F-3-30-3
SCREW, TAPPING, 5X12.....	F-15-74	SPRING, COIL.....	FOP-10-40	TUBE C, AIR VENT.....	E-18-6
SCREW, TAPPING, 5X25.....	F-15-76	SPRING, COMPRESSION.....	E-18-20-41	TUBE C, BREATHER.....	E-15-23
SCREW, TAPPING, 5X8.....	F-15-72	SPRING, EX. VALVE.....	E-9-20	TUBE C, FUEL.....	E-18-10-7
SCREW, TAPPING, 6X16.....	F-15-75	SPRING, FLUSH VALVE	F-3-30-5	TUBE COMP. A, FUEL.....	E-18-10-5
SCREW, TAPPING, 6X30.....	FOP-4-4-24	SPRING, GEAR SHIFT	F-15-1-20	TUBE COMP. B, FUEL.....	E-18-10-6
SCREW, TRUSS, 4X12.....	FOP-4-4-21	SPRING, IN. VALVE	E-9-19	TUBE D, FUEL.....	E-18-11
SCREW, WASHER.....	E-18-20-21	SPRING, MOTOR.....	F-11-8	TUBE E, FUEL.....	E-18-12
SCREW-WASHER.....	E-18-20-17	SPRING, NEUTRAL LOCK ARM	FOP-4-4-7	TUBE KIT, SPEED SENSOR.....	F-3-1
SCREW-WASHER.....	E-18-20-18	SPRING, RELIEF VALVE	E-5-5	TUBE(38.1X40).....	FOP-10-8
SCREW-WASHER.....	E-18-20-20	SPRING, REMOTE CONTROL HANDLE ..	F-15-8	TUBE, 5X950.....	F-3-44
SCREW-WASHER, 3X7.....	F-7-19	SPRING, REMOTE CONTROL HANDLE ..	F-15-1-5	TUBE, 7X110.....	F-3-30-24
SCREW-WASHER, 5X10.....	F-7-21	SPRING, SHIFT.....	F-5-6	TUBE, CORD, 40MM.....	FOP-10-92
SEAL A, COVER UNDER.....	F-3-30-13	SPRING, SHIFT CLICK.....	F-15-25	TUBE, CORRUGATE(28MM).....	F-15-1
SEAL A, VALVE STEM(NOK).....	E-2-4	SPRING, SHIFT CLICK.....	F-15-1-24	TUBE, FUEL, 8X300.....	F-8-43
SEAL B, COVER UNDER.....	F-3-25	SPRING, SHIFT ROD.....	F-4-11	TUBE, FUEL,3.5 X 120.....	E-18-20-54
SEAL B, VALVE STEM(NOK).....	E-2-6	SPROCKET, CAM CHAIN DRIVEN.....	E-9-2	TUBE, OIL.....	E-1-3
SEAL, ENGINE COVER	F-8-14	SPROCKET, CAM CHAIN(23T).....	E-7-11	TUBE, SPEED SENSOR	F-3-14
SEAL, UPPER MOUNT COVER.....	F-10-11	STATOR.....	E-19-3	TUBE, SPIRAL.....	F-3-5
SEAL, WATER.....	F-11-42	STAY, FUEL TUBE	E-18-20-33	TUBE, SPIRAL(12X14.6).....	F-11-3
SEAL, WATER CHECK GROMMET.....	F-8-23	STAY, POWER TILT SWITCH.....	F-8-7	TUBE, VINYL, 4X7X190	E-15-25
SEAL, WATER, 12X21X6.....	F-4-32	STOPPER.....	FOP-10-34	TUBE, VINYL, 5X9X240	E-18-20-55
SEAL, WATER, 22X35X7.....	F-3-30-20	STOPPER ASSY., ENGINE SIDE	F-8-11	TUBE, WATER CHECK.....	F-3-30-23
SEAL, WATER, 23X36X6.....	F-4-31	STOPPER SET, SLEEVE.....	E-21-8	TUBE, WATER(L).....	F-4-8
SEAL, WATER, 30X45X7.....	F-5-23	STOPPER, LOWER MOUNT.....	F-3-18	TUBE, WATER(XL).....	F-4-8
SEAT, VALVE SPRING.....	E-9-22	STOPPER, TILT.....	F-10-22	<V>	
SEAT, WATER MOUTH.....	F-8-4	STOPPER, UPPER MOUNT	F-10-9	VALVE ASSY., ELECTRONIC AIR	E-14-10
SENSOR ASSY., AIR TEMP.....	E-15-13	STRAINER COMP., FUEL	E-18-15	VALVE ASSY., RELIEF.....	F-3-30-6
SENSOR ASSY., AIR TEMP.....	E-15-13	STRAINER COMP., FUEL	E-18-10-9	VALVE ASSY., SPOOL.....	E-2-10
SENSOR ASSY., CRANK	E-9-10-5	STRAINER COMP., OIL.....	E-6-3	VALVE COMP., MANUAL	F-11-21
SENSOR ASSY., MAP	E-15-11	STRAP, HARNESS(30)(BLACK).....	F-7-10	VALVE COMP., RESERVOIR.....	F-11-22
SENSOR ASSY., TDC.....	E-2-25	SUB HARNESS ASSY., POWER.....	FOP-4-19	VALVE SET, FLOAT.....	E-18-20-1
SENSOR ASSY., TRIM ANGLE.....	F-10-5	SUB HARNESS ASSY., POWER.....	FOP-4-2-20	VALVE, CHECK.....	E-18-17
SENSOR ASSY., WATER.....	E-2-24	SUB HARNESS ASSY., POWER.....	FOP-4-2-21	VALVE, EX.....	E-9-17
SENSOR ASSY., WATER.....	E-3-16	SUB HARNESS ASSY., POWER.....	FOP-4-4-16	VALVE, FLASH.....	F-3-30-7
SENSOR COMP., KNOCK.....	E-3-12	SUSPENSION, COUPLER.....	F-7-12	VALVE, IN.....	E-9-16
SENSOR, OIL PRESSURE.....	E-3-35	SUSPENSION, STRAINER.....	E-18-10-10	VALVE, RELIEF.....	E-5-4
SENSOR, OXYGEN.....	E-2-23	SUSPENSION, WARNING BUZZER.....	FOP-10-26	<W>	
SEPARATOR ASSY., VAPOR.....	E-18-20-31	SWITCH ASSY., COMBINATION	F-15-39	WASHER.....	F-15-1-42
SEPARATOR ASSY., WATER.....	E-18-10-2	SWITCH ASSY., COMBINATION	FOP-6-13	WASHER.....	F-15-1-43
SEPARATOR, EXTENSION(XL).....	F-3-10-2	SWITCH ASSY., COMBINATION	FOP-6-1-7	WASHER, 10MM.....	F-10-48
SHAFT ASSY., CLUTCH	E-21-13	SWITCH ASSY., COMBINATION	FOP-10-17	WASHER, 10MM.....	FOP-10-78
SHAFT ASSY., GEAR.....	E-21-14	SWITCH ASSY., EMERGENCY STOP.....	F-15-42	WASHER, 10MM.....	FOP-10-81
SHAFT ASSY., PROPELLER.....	F-5-10	SWITCH ASSY., EMERGENCY STOP.....	F-15-1-28	WASHER, 13MM.....	F-2-33
SHAFT COMP., ROCKER ARM	E-9-13	SWITCH ASSY., EMERGENCY STOP.....	FOP-6-14	WASHER, 14MM.....	F-2-32
SHAFT COMP., SHIFT.....	F-2-18	SWITCH ASSY., EMERGENCY STOP.....	FOP-6-1-8	WASHER, 26MM.....	F-3-10-25
SHAFT, GEAR SHIFT	F-15-1-19	SWITCH ASSY., EMERGENCY STOP.....	FOP-10-21	WASHER, 28MM.....	F-15-62
SHAFT, HANDLE.....	F-15-1-17	SWITCH ASSY., MAGNET	E-21-12	WASHER, 5MM.....	FOP-10-76
SHAFT, OIL PUMP.....	E-5-3	SWITCH ASSY., NEUTRAL.....	F-2-19	WASHER, 5MM.....	FOP-10-79
SHAFT, PROPELLER.....	F-5-11	SWITCH ASSY., POWER TILT	F-8-6	WASHER, 6MM.....	F-15-60
SHAFT, STEERING FRICTION	FOP-10-57	SWITCH ASSY., POWER TILT	FOP-10-18	WASHER, 8MM.....	F-4-25
SHAFT, THROTTLE BUTTON	FOP-4-4-9	SWITCH ASSY., POWER TRIM-TILT	F-15-40	WASHER, 8MM.....	FOP-3-11
SHAFT, TILTING.....	F-10-18	SWITCH ASSY., POWER TRIM-TILT	F-15-1-30	WASHER, 8MM.....	FOP-10-77
SHAFT, VERTICAL(L).....	F-4-16	SWITCH ASSY., POWER TRIM-TILT	FOP-4-20	WASHER, DRAIN PLUG, 12MM.....	E-6-13
SHAFT, VERTICAL(UL).....	F-4-16	SWITCH ASSY., POWER TRIM-TILT	FOP-4-2-22	WASHER, DRAIN PLUG, 20MM.....	E-2-40
SHIFTER, CLUTCH.....	F-5-1	SWITCH ASSY., POWER TRIM-TILT	FOP-4-2-23	WASHER, IN. WAVE	E-9-15
SHIM A, BEVEL(FR.)(0.10).....	F-5-17	SWITCH ASSY., POWER TRIM-TILT	FOP-4-4-17	WASHER, LOCK, 5MM.....	FOP-4-30
SHIM A, GEAR(0.10).....	F-4-26	SWITCH ASSY., TROLLING CONTROL ..	FOP-12-1	WASHER, LOCK, 5MM.....	FOP-4-2-35
SHIM B, BEVEL(FR.)(0.15).....	F-5-17	<T>		WASHER, LOCK, 5MM.....	FOP-4-4-26
SHIM B, GEAR(0.15).....	F-4-26	TAB, TRIM	F-3-10-10	WASHER, LOCK, 6MM.....	FOP-4-32
SHIM C, BEVEL(FR.)(0.30).....	F-5-17	TACHOMETER HOUR METER (BLACK) ..	FOP-7-4	WASHER, LOCK, 6MM.....	FOP-4-2-37
SHIM C, GEAR(0.30).....	F-4-26	TANK, OIL.....	F-11-25	WASHER, PIVOT.....	F-2-8
SHIM D, BEVEL(FR.)(0.50).....	F-5-17	TENSIONER COMP., CAM CHAIN.....	E-9-10	WASHER, PLAIN.....	E-18-20-22
SHIM D, GEAR(0.50).....	F-4-26	TERMINAL, CABLE	FOP-4-16	WASHER, PLAIN, 10MM.....	F-3-10-27
SLIDER COMP., CAM CHAIN	E-9-11	TERMINAL, CABLE	FOP-4-2-17	WASHER, PLAIN, 10MM.....	F-3-10-27

WASHER, PLAIN, 10MM	F-10-49
WASHER, PLAIN, 10MM	F-10-53
WASHER, PLAIN, 12MM	F-3-36
WASHER, PLAIN, 12MM	F-4-23
WASHER, PLAIN, 12MM	F-10-50
WASHER, PLAIN, 12MM	F-10-51
WASHER, PLAIN, 12MM	F-10-52
WASHER, PLAIN, 12MM	FOP-10-82
WASHER, PLAIN, 12MM	FOP-10-83
WASHER, PLAIN, 18.5MM	F-5-16
WASHER, PLAIN, 4MM	F-15-56
WASHER, PLAIN, 5MM	F-15-57
WASHER, PLAIN, 5MM	F-15-58
WASHER, PLAIN, 5MM	FOP-4-31
WASHER, PLAIN, 5MM	FOP-4-33
WASHER, PLAIN, 5MM	FOP-4-2-36
WASHER, PLAIN, 5MM	FOP-4-2-38
WASHER, PLAIN, 5MM	FOP-6-25
WASHER, PLAIN, 5MM	FOP-6-1-18
WASHER, PLAIN, 6MM	E-15-20
WASHER, PLAIN, 6MM	F-2-31
WASHER, PLAIN, 6MM	F-4-24
WASHER, PLAIN, 6MM	F-8-34
WASHER, PLAIN, 6MM	F-15-59
WASHER, PLAIN, 6MM	FOP-4-4-27
WASHER, PLAIN, 8MM	F-2-34
WASHER, PLAIN, 8MM	F-3-10-26
WASHER, PLAIN, 8MM	F-7-10-32
WASHER, PLAIN, 8MM	F-15-61
WASHER, PLAIN, 8MM	FOP-10-75
WASHER, PROPELLER THRUST.....	F-5-15
WASHER, SEALING, 18MM.....	E-5-6
WASHER, SEALING, 24MM.....	E-3-2
WASHER, SEALING, 6MM.....	E-18-20-50
WASHER, SHIFT SHAFT.....	F-2-30
WASHER, SIDE, 14MM.....	F-2-29
WASHER, SPRING, 4MM.....	FOP-12-9
WASHER, SPRING, 5MM.....	FOP-6-26
WASHER, SPRING, 5MM.....	FOP-6-1-19
WASHER, THRUST.....	E-7-9
WASHER, THRUST.....	E-9-14
WASHER, THRUST, 13MM.....	E-5-13
WASHER, THRUST, 34MM.....	F-10-47
WASHER, WAVE, 14MM.....	FOP-10-80
WASHER, WAVE, 26MM.....	F-10-46
WASHER, WAVE, 40MM.....	F-10-45
WATER SEAL, 14X26X6.....	F-2-40
WHEEL, ACCELERATOR.....	F-15-21
WHEEL, CONTROL.....	F-15-14
WHEEL, CONTROL.....	F-15-1-16
WIRE, FASTENER.....	F-3-23
WIRE, FASTENER.....	F-8-16
WIRE, LEAD(1.5X116MM).....	F-11-9
WIRE, LEAD(1.5X137MM).....	F-3-12
WRENCH, BOX(P18X19).....	F-13-13
WRENCH, PLUG.....	F-13-8
<Y>	
YOKE ASSY.....	F-11-7
YOKE COMP.....	E-21-4

INDEX (Parts Number)

332-70201-0	F-6-8	HCO-95001-35120-40	E-18-20-54	HPNA-90003-000	E-9-24	HSF4-89216-000	F-13-8
3C7-70217-0	F-6-5	HCO-95001-80300-40	F-8-43	HPNA-91214-014	E-3-28	HSJ6-91558-003	F-7-10
3C7-70220-1	F-6-2	HCO-95003-07019-31	E-15-25	HPNA-91302-003	E-14-21	HSTK-91540-003	F-2-42
3C7-70224-1	F-6-3	HCO-95003-11024-31	E-18-20-55	HPNA-91307-003	E-2-36	HSTK-91540-003	FOP-11-6
3FF-70200-4	F-6-1	HCO-95005-50950-30	F-3-44	HPNA-91307-003	E-3-31	HSW5-91551-003	F-7-9
3GF-70211-1	F-6-4	HCO-95005-70110-30	F-3-30-24	HPNA-91333-003	E-2-37	HSZ5-91531-003	F-7-10-19
3GF-70240-1	F-6-7	HCO-96100-62080-00	F-5-26	HPNA-91333-003	E-9-10-14	HVF9-89203-003	F-13-15
3GF-70241-1	F-6-6	HCO-96211-07000	F-5-27	HPNB-37500-003	E-9-10-5	HVM0-46391-003	F-2-21
3PU-72537-0	FOP-7-6	HCO-96211-11000	F-5-28	HPP4-90009-E01	E-18-20-46	HZB7-90691-003	E-2-35
3PV-72571-0	FOP-7-1	HCO-96220-50178	E-5-16	HPR3-91319-003	E-3-32	HZC0-63515-700	F-3-24
3PV-72637-0	FOP-7-4	HCO-96300-06014-09	E-3-34	HPT0-90206-004	E-9-28	HZE2-90601-000	E-6-13
H341-38403-672	F-15-46	HCO-96300-06014-09	E-9-30	HPWA-11106-300	E-3-1	HZH8-28461-013	F-13-1
H341-38403-672	FOP-6-19	HCO-96300-06016-09	E-6-18	HPWA-11107-300	E-3-2	HZV0-90017-C10	E-5-10
H341-38403-672	FOP-6-1-12	HCO-96300-06028-09	E-9-31	HPWA-13111-000	E-7-3	HZV0-90017-C10	F-2-24
H723-90472-000	F-4-23	HCO-96300-08100-09	E-6-19	HPWA-13204-003	E-7-4	HZV0-90123-010	E-19-5
H750-90628-000	F-3-37	HCO-96300-08120-09	E-6-20	HPWA-13211-003	E-7-6	HZV0-90604-000	E-18-22
H763-90681-A01	F-7-20-3	HCO-9807B-5617C	E-20-3	HPWA-13212-003	E-7-6	HZV0-90604-000	E-18-10-18
H763-90681-A01	F-10-55	HCO-98200-41000	F-7-24	HPWA-13213-003	E-7-6	HZV1-24210-010	F-10-3
H800-91303-000	F-3-30-21	HCO-98200-41500	F-7-25	HPWA-13214-003	E-7-6	HZV1-90127-010	E-5-11
H881-19271-811	F-13-17	HCO-98200-43000	F-7-26	HPWA-13215-003	E-7-6	HZV1-90127-010	E-15-18
H881-90110-000	F-10-33	HCO-99003-10000	F-13-16	HPWA-13216-003	E-7-6	HZV1-90506-000	FOP-10-80
H921-17936-000	F-2-8	HCO-99003-50000	F-13-6	HPWA-13217-003	E-7-6	HZV1-90759-000	FOP-10-86
H921-90302-000	F-8-33	HCO-99004-18190	F-13-13	HPWA-13322-003	E-7-8	HZV3-53104-000	FOP-10-31
H921-90302-000	F-15-54	HCO-99008-02000	F-13-14	HPWA-13323-003	E-7-8	HZV4-16910-015	E-18-15
H921-90302-000	FOP-6-23	HGE1-17357-670	F-3-2	HPWA-13324-003	E-7-8	HZV4-24221-010	F-10-4
H921-90302-000	FOP-6-1-16	HGET-90429-000	F-2-29	HPWA-13325-003	E-7-8	HZV4-36182-651	F-15-43
H921-90302-000	FOP-10-72	HGHB-16163-600	F-3-30-25	HPWA-13326-003	E-7-8	HZV4-36182-651	FOP-6-15
H921-90504-010	F-15-59	HGHB-16163-610	E-18-20-23	HPWA-13327-003	E-7-8	HZV4-36182-651	FOP-6-1-9
H921-90511-000	F-10-49	HGJ5-80103-000	F-8-21	HPWA-13328-003	E-7-8	HZV4-36182-651	FOP-10-22
H921-90512-010	F-15-60	HHA0-32121-003	F-7-10-2	HPWA-13342-003	E-7-10	HZV4-36187-652	F-15-44
H921-90514-000	F-4-25	HPF5-91304-601	FOP-10-90	HPWA-13343-003	E-7-10	HZV4-36187-652	FOP-6-16
H921-90514-000	FOP-3-11	HHW1-90114-671	E-6-10	HPWA-13344-003	E-7-10	HZV4-36187-652	FOP-6-1-10
H921-90518-000	F-2-34	HHW1-90118-671	FOP-10-70	HPWA-13345-003	E-7-10	HZV4-36187-652	FOP-10-23
H921-90518-000	F-15-61	HHW1-90120-671	E-3-25	HPWA-13346-003	E-7-10	HZV4-90302-000	F-3-10-23
H952-32901-770	F-15-38	HHW1-90120-671	E-6-11	HPWA-13347-003	E-7-10	HZV4-90304-000	F-15-55
H952-32901-770	FOP-6-12	HHW1-90214-671	F-10-37	HPWA-13348-003	E-7-10	HZV4-90305-000	FOP-10-74
H965-77212-000	F-8-20	HHW1-90215-671	F-10-38	HPWA-14221-003	E-9-3	HZV4-90502-000	F-15-58
HCO-92101-04020-4J	FOP-12-7	HHW1-90225-670	F-3-10-22	HPWA-14647-000	E-9-14	HZV4-90502-000	FOP-4-31
HCO-92101-05016-4J	F-15-70	HKF0-91305-003	F-2-41	HPWA-17105-007	E-14-7	HZV4-90502-000	FOP-4-2-36
HCO-93500-05010-4J	F-15-71	HKM3-32161-003	F-3-3	HPWA-90008-003	E-2-26	HZV4-90507-000	F-3-10-26
HCO-93500-05065-4J	FOP-4-34	HMAL-91302-601	E-3-29	HPWA-90017-G02	E-19-4	HZV4-90511-000	F-4-24
HCO-93500-05065-4J	FOP-4-2-39	HMB0-91359-000	F-4-35	HPWA-91212-003	E-9-10-13	HZV4-90514-000	F-10-48
HCO-93500-06018-4J	E-2-39	HMB6-61102-631	F-8-12	HPWC-14631-010	E-9-13	HZV4-90514-000	FOP-10-81
HCO-93901-250J0	F-15-72	HMC7-90456-000	E-5-13	HPWC-14721-010	E-9-17	HZV4-90603-000	F-3-30-19
HCO-93901-251J0	F-15-73	HMG9-35701-950	F-3-4	HPWC-30520-S01	E-20-1	HZV4-91255-651	F-2-40
HCO-93901-252J0	F-15-74	HMG9-35701-950	F-15-41	HPWC-90006-003	E-9-25	HZV5-12155-000	E-2-1
HCO-93903-262J0	F-15-75	HMG9-91058-681	F-15-65	HPY3-14647-000	E-9-15	HZV5-17202-310	F-3-30-2
HCO-93905-255J0	F-15-76	HMJ0-91301-003	E-14-19	HPY3-17439-A01	E-18-10-13	HZV5-17202-310	F-7-10-1
HCO-94001-04490-05	FOP-12-8	HMJ0-91301-003	E-18-20-52	HPY3-31215-004	E-21-3	HZV5-17838-000	F-2-1
HCO-94001-05490-05	F-2-43	HMJ0-91308-003	F-4-33	HPY3-31218-004	E-21-6	HZV5-24811-010	F-15-3
HCO-94001-05490-05	FOP-4-35	HMJ6-32660-710	F-7-10-8	HPZ1-12210-004	E-2-4	HZV5-24812-000	F-15-4
HCO-94001-05490-05	FOP-4-2-40	HMM4-90105-000	F-15-51	HPZ1-12211-004	E-2-6	HZV5-24813-000	F-15-5
HCO-94001-06490-05	F-15-77	HMR5-16966-000	E-15-5	HPZA-14820-013	E-2-9	HZV5-24814-010	F-15-6
HCO-94001-12490-05	F-10-61	HMT8-18334-770	FOP-6-3	HRAA-15815-A02	E-2-11	HZV5-24815-010	F-15-7
HCO-94002-05490-05	F-15-78	HMT8-18334-770	FOP-6-1-2	HRB0-14211-003	E-9-2	HZV5-24816-000	F-15-8
HCO-94002-06490-05	FOP-10-94	HMV5-91005-601	F-5-19	HRB0-14711-000	E-9-16	HZV5-24817-000	F-15-9
HCO-94002-12490-05	FOP-10-95	HP08-14775-000	E-9-22	HRB1-14401-003	E-9-5	HZV5-24818-003	F-15-10
HCO-94103-05400	FOP-6-25	HP2A-37881-000	E-15-14	HRB1-14530-004	E-9-12	HZV5-24820-010	F-15-11
HCO-94103-05400	FOP-6-1-18	HP3F-36533-A01	E-18-18	HRE1-37880-Z01	E-15-13	HZV5-24830-010	F-15-12
HCO-94109-20000	E-2-40	HPC6-15234-000	E-5-6	HrgA-14765-000	E-9-21	HZV5-24836-000	F-15-13
HCO-94111-04500	FOP-12-9	HPC6-91310-004	E-6-15	HrgA-30530-004	E-3-12	HZV5-24841-000	F-15-14
HCO-94111-05400	FOP-6-26	HPD2-90701-000	E-3-27	HrgM-14781-A01	E-9-23	HZV5-24845-000	F-15-15
HCO-94111-05400	FOP-6-1-19	HPD6-90403-003	E-18-20-50	HRMA-16723-E00	E-18-10-1	HZV5-24850-000	F-15-16
HCO-94301-06100	E-6-17	HPED0-15231-000	E-5-4	HRNA-37260-A01	E-3-35	HZV5-24854-000	F-15-17
HCO-94301-07120	E-9-29	HPF4-91324-004	E-3-33	HRNA-37830-A01	E-15-11	HZV5-24855-000	F-15-18
HCO-94301-14200	E-2-41	HPG6-15232-000	E-5-5	HRNA-90031-A01	E-9-26	HZV5-24860-000	F-15-19
HCO-94510-14000	F-5-25	HPG7-16741-005	E-18-20-36	HRTA-15400-004	E-3-5	HZV5-24865-000	F-15-20
HCO-94540-03029	F-15-79	HPGK-37835-A01	E-15-12	HS04-38235-003	F-13-4	HZV5-24875-000	F-15-21
HCO-94540-04029	F-2-44	HPH1-90015-013	E-3-19	HS0A-91540-003	E-19-6	HZV5-24876-000	F-15-22
HCO-94540-04029	F-3-43	HPH3-16638-S00	E-14-4	HS0A-91541-003	E-2-38	HZV5-24878-000	F-15-23
HCO-94540-04029	F-15-80	HPH7-90704-000	E-7-14	HS0A-91541-003	F-7-8	HZV5-24881-000	F-15-24
HCO-94540-06029	F-2-45	HPJ7-12204-305	E-2-2	HSAA-90683-003	F-7-10-33	HZV5-24883-000	F-15-25
HCO-94540-06029	FOP-4-36	HPJ7-12205-305	E-2-3	HSB0-90602-003	F-8-35	HZV5-24884-000	F-15-26
HCO-94540-06029	FOP-4-2-41	HPJ7-91309-010	F-3-30-22	HSB2-90153-003	F-7-21	HZV5-24885-000	F-15-27
HCO-94540-06029	FOP-4-4-28	HPLC-37880-004	E-15-13	HSB6-91475-000	F-15-67	HZV5-24887-000	F-15-28
HCO-94540-70209	F-15-81	HPLC-91301-000	E-14-20	HSC2-90649-003	FOP-6-24	HZV5-24891-000	F-15-29
HCO-94540-10019	F-4-37	HPM3-14744-000	E-9-18	HSC2-90649-003	FOP-6-1-17	HZV5-24892-000	F-15-30
HCO-94540-12029	F-2-46	HPM3-90206-004	E-9-27	HSD2-90705-931	F-2-36	HZV5-24894-000	F-15-31
HCO-94540-15029	F-11-45	HPN4-19526-000	E-18-10-14	HSE0-53740-953	E-18-10-16	HZV5-24895-000	F-15-32

HZV5-24897-000.	F-15-33	HZW1-06411-020.	F-10-1	HZW1-58130-V13.	FOP-8-1	HZW1-91557-701.	F-11-44
HZV5-24898-000.	F-15-34	HZW1-12217-010.	E-2-7	HZW1-58130-W03ZA.	FOP-8-1	HZW2-90003-000.	E-15-15
HZV5-32823-003.	F-15-36	HZW1-15236-010.	E-5-7	HZW1-58130-W13ZA.	FOP-8-1	HZW2-90003-000.	E-20-10-10
HZV5-32823-003.	FOP-6-10	HZW1-15331-000.	E-5-8	HZW1-58130-W24ZA.	FOP-8-1	HZW2-90003-000.	F-7-17
HZV5-32823-003.	FOP-6-1-5	HZW1-15341-000.	E-5-9	HZW1-58130-W33ZA.	FOP-8-1	HZW2-90003-000.	F-7-10-42
HZV5-32823-003.	FOP-10-16	HZW1-17736-000.	F-15-1	HZW1-58130-W43ZB.	FOP-8-1	HZW2-90003-000.	F-8-24
HZV5-32823-003.	FOP-11-3	HZW1-19234-B00.	F-4-5	HZW1-58130-W64ZA.	FOP-8-1	HZW2-90301-F00.	E-14-18
HZV5-32824-003.	F-15-37	HZW1-19234-B00.	FOP-3-7	HZW1-58130-W93.	FOP-8-1	HZW4-17931-H02.	FOP-10-4
HZV5-32824-003.	FOP-6-11	HZW1-19242-B00.	F-4-7	HZW1-87538-740.	F-12-15	HZW4-19312-H00.	F-3-30-10
HZV5-32824-003.	FOP-6-1-6	HZW1-19242-B00.	FOP-3-8	HZW1-87705-003.	F-15-1-31	HZW4-24614-H03.	FOP-10-6
HZV5-32824-003.	FOP-10-96	HZW1-19252-000.	E-6-5	HZW1-87706-003.	F-15-1-32	HZW4-24615-H03.	FOP-10-7
HZV5-32824-003.	FOP-11-4	HZW1-19253-B01.	F-4-9	HZW1-87707-003.	F-15-1-32	HZW4-32533-H01.	FOP-10-8
HZV5-35370-823.	F-15-40	HZW1-19253-B01.	FOP-3-9	HZW1-90002-010.	E-7-13	HZW4-32543-H01.	FOP-10-11
HZV5-36136-821.	F-11-8	HZW1-19286-B00.	F-3-10-1	HZW1-90014-000.	E-14-13	HZW4-32544-H01.	FOP-10-12
HZV5-36180-033.	F-15-42	HZW1-24102-B00.	F-5-2	HZW1-90014-000.	E-18-20-47	HZW4-32547-H01.	FOP-10-13
HZV5-36180-033.	FOP-6-14	HZW1-24103-B00.	F-5-3	HZW1-90102-000.	F-10-28	HZW4-32548-H01.	FOP-10-14
HZV5-36180-033.	FOP-6-1-8	HZW1-24210-010.	F-2-9	HZW1-90104-900.	F-3-10-14	HZW4-32549-H01.	FOP-10-15
HZV5-36180-033.	FOP-10-21	HZW1-24320-B00.	F-4-12	HZW1-90105-000.	F-10-30	HZW4-35640-H11.	FOP-10-18
HZV5-38410-003.	F-15-47	HZW1-24327-000.	F-4-13	HZW1-90107-004.	E-21-21	HZW4-35643-H02.	FOP-10-19
HZV5-38410-003.	FOP-6-20	HZW1-24629-000.	F-2-17	HZW1-90108-000.	F-10-32	HZW4-35645-H02.	FOP-10-20
HZV5-38410-003.	FOP-6-1-13	HZW1-24800-V21.	F-15-1-1	HZW1-90113-702.	F-11-27	HZW4-53104-H02.	FOP-10-32
HZV5-40102-000.	E-9-10-6	HZW1-24811-V21.	F-15-1-2	HZW1-90114-702.	F-11-28	HZW4-53106-H01.	FOP-10-34
HZV5-40102-000.	F-3-6	HZW1-24812-V21.	F-15-1-3	HZW1-90115-702.	F-11-29	HZW4-53107-H02.	FOP-10-35
HZV5-40102-000.	F-7-30-2	HZW1-24813-V21.	F-15-1-4	HZW1-90116-702.	F-11-30	HZW4-53109-H02.	FOP-10-37
HZV5-40102-000.	F-8-8	HZW1-24816-V21.	F-15-1-5	HZW1-90124-910.	F-3-10-18	HZW4-53112-H02.	FOP-10-38
HZV5-41172-000.	F-3-13	HZW1-24819-V21.	F-15-1-6	HZW1-90125-910.	F-3-10-19	HZW4-53113-H01.	FOP-10-39
HZV5-41172-000.	F-3-45	HZW1-24820-V21.	F-15-1-7	HZW1-90136-003.	F-15-1-33	HZW4-53114-H01.	FOP-10-40
HZV5-50214-003.	F-11-10	HZW1-24821-003.	F-15-1-8	HZW1-90137-003.	F-15-1-34	HZW4-53115-H02.	FOP-10-98
HZV5-50522-000.	F-10-20	HZW1-24822-V21.	F-15-1-9	HZW1-90138-003.	F-15-1-35	HZW4-53116-H01.	FOP-10-41
HZV5-56117-821.	F-11-17	HZW1-24825-V01.	F-15-1-10	HZW1-90139-003.	F-15-1-36	HZW4-53116-H11.	FOP-10-42
HZV5-56118-820.	F-11-18	HZW1-24829-003.	F-15-1-11	HZW1-90140-003.	F-15-1-37	HZW4-53117-H01.	FOP-10-43
HZV5-56513-000.	F-11-23	HZW1-24830-V21.	F-15-1-12	HZW1-90142-003.	F-15-1-38	HZW4-53118-H03.	FOP-10-44
HZV5-90010-000.	F-4-19	HZW1-24834-003.	F-15-1-13	HZW1-90143-003.	F-15-1-39	HZW4-53119-H02.	FOP-10-45
HZV5-90010-000.	FOP-3-10	HZW1-24836-V21.	F-15-1-14	HZW1-90145-003.	F-15-1-40	HZW4-53121-H02.	FOP-10-46
HZV5-90115-000.	F-3-10-15	HZW1-24839-V01.	F-15-1-15	HZW1-90203-000.	F-7-22	HZW4-53122-H01.	FOP-10-47
HZV5-90119-000.	F-3-32	HZW1-24841-V01.	F-15-1-16	HZW1-90203-000.	F-7-10-30	HZW4-53123-H01.	FOP-10-48
HZV5-90119-000.	F-3-33	HZW1-24843-V01.	F-15-1-17	HZW1-90242-000.	F-4-21	HZW4-53141-H00.	FOP-10-51
HZV5-90119-000.	F-11-31	HZW1-24845-V01.	F-15-1-18	HZW1-90301-B00.	F-5-14	HZW4-90101-H00.	FOP-10-62
HZV5-90125-000.	F-15-53	HZW1-24847-V01.	F-15-1-19	HZW1-90303-B03.	F-4-22	HZW4-90102-H01.	FOP-10-63
HZV5-90127-003.	F-3-34	HZW1-24848-V01.	F-15-1-20	HZW1-90304-013.	F-10-41	HZW4-90103-H02.	FOP-10-65
HZV5-90127-003.	F-8-29	HZW1-24865-V01.	F-15-1-21	HZW1-90314-003.	F-15-1-41	HZW4-90104-H01.	FOP-10-67
HZV5-90131-000.	E-6-12	HZW1-24870-V21.	F-15-1-22	HZW1-90401-000.	FOP-10-75	HZW4-90105-H02.	FOP-10-68
HZV5-90202-003.	F-2-208	HZW1-24873-V01.	F-15-1-23	HZW1-90501-710.	F-3-10-25	HZW4-90106-H01.	FOP-10-69
HZV5-90304-013.	F-10-40	HZW1-24883-V01.	F-15-1-24	HZW1-90506-B00.	F-5-15	HZW4-90108-000.	F-15-52
HZV5-90306-003.	F-3-10-24	HZW1-31217-004.	E-21-5	HZW1-90508-B00.	F-5-16	HZW4-90126-000.	E-14-16
HZV5-90307-003.	F-10-44	HZW1-31250-004.	E-21-17	HZW1-90518-B00.	F-4-26	HZW4-90145-000.	E-9-10-12
HZV5-90501-000.	F-10-45	HZW1-31261-004.	E-21-18	HZW1-90519-B00.	F-4-26	HZW4-90147-000.	E-2-34
HZV5-90502-000.	F-10-46	HZW1-35180-003.	F-15-1-28	HZW1-90520-B00.	F-4-26	HZW4-90151-000.	F-10-35
HZV5-90504-000.	F-10-47	HZW1-35182-003.	F-15-1-29	HZW1-90521-B00.	F-4-26	HZW4-90155-000.	E-5-12
HZV5-90552-000.	F-10-50	HZW1-35370-V01.	F-15-1-30	HZW1-90528-B00.	F-5-17	HZW4-90159-000.	E-21-22
HZV5-90552-000.	FOP-10-82	HZW1-36122-013.	F-11-5	HZW1-90529-B00.	F-5-17	HZW4-90168-000.	F-8-31
HZV5-90557-000.	F-15-62	HZW1-36123-013.	F-11-6	HZW1-90530-B00.	F-5-17	HZW4-90169-000.	E-15-19
HZV5-90559-000.	F-10-51	HZW1-38551-000.	F-7-16	HZW1-90531-B00.	F-5-17	HZW4-90301-H01.	FOP-10-71
HZV5-90559-000.	F-10-52	HZW1-40107-700.	F-3-8	HZW1-90551-003.	F-15-1-42	HZW4-90303-H00.	FOP-10-73
HZV5-90559-000.	FOP-10-83	HZW1-40204-000.	F-4-15	HZW1-90552-003.	F-15-1-43	HZW4-90306-003.	F-10-43
HZV5-90563-000.	F-3-10-27	HZW1-40210-710.	F-3-10-3	HZW1-90559-000.	F-3-36	HZW4-90306-003.	F-10-63
HZV5-90563-000.	F-3-10-27	HZW1-41102-B00.	F-3-10-5	HZW1-90651-710.	F-3-10-28	HZW4-90401-000.	F-15-56
HZV5-90563-000.	F-10-53	HZW1-41109-B00.	F-3-10-11	HZW1-90652-702.	F-11-32	HZW4-90402-000.	F-15-57
HZV5-90751-000.	F-15-63	HZW1-41112-B03.	F-4-16	HZW1-90653-003.	F-15-1-44	HZW4-90501-H01.	FOP-10-76
HZV5-90756-000.	E-6-14	HZW1-41112-B33.	F-4-16	HZW1-90752-B02.	F-4-27	HZW4-90502-H02.	FOP-10-77
HZV5-90756-000.	F-3-40	HZW1-41116-B00.	F-4-17	HZW1-90752-B02.	FOP-3-12	HZW4-90503-H01.	FOP-10-78
HZV5-90756-000.	F-3-10-29	HZW1-41131-B01.	F-4-18	HZW1-90753-003.	F-15-1-45	HZW4-90504-H01.	FOP-10-79
HZV5-90756-000.	F-3-10-29	HZW1-41201-B02ZD.	F-5-12	HZW1-90758-B00.	F-5-18	HZW4-90651-000.	F-10-54
HZV5-90756-000.	F-4-28	HZW1-50161-020ZC.	F-3-19	HZW1-90953-003.	F-15-1-46	HZW4-90651-H01.	FOP-10-84
HZV5-90772-000.	F-15-64	HZW1-50214-000.	F-10-14	HZW1-91051-B02.	F-5-20	HZW4-90652-H01.	FOP-10-85
HZV5-91151-000.	F-15-66	HZW1-50527-000.	F-10-21	HZW1-91052-B02.	F-4-29	HZW4-91051-H02.	FOP-10-88
HZV5-91203-821.	F-11-33	HZW1-50529-000.	F-10-22	HZW1-91054-B31.	F-4-30	HZW4-91052-H01.	FOP-10-89
HZV5-91256-003.	F-10-57	HZW1-53234-010.	F-10-23	HZW1-91101-003.	F-5-22	HZW4-91301-003.	F-3-10-30
HZV5-91302-821.	F-11-35	HZW1-53236-700.	FOP-10-55	HZW1-91207-013.	F-11-34	HZW4-91552-H00.	FOP-10-93
HZV5-91316-821.	F-11-36	HZW1-53238-010.	F-10-24	HZW1-91302-000.	E-5-14	HZW5-06241-U00.	FOP-4-2
HZV5-91352-000.	F-10-58	HZW1-53238-700.	FOP-10-56	HZW1-91351-B02.	F-5-24	HZW5-06241-U10.	FOP-4-2-2
HZV5-91352-000.	FOP-10-91	HZW1-53239-701.	FOP-10-57	HZW1-91352-702.	F-11-37	HZW5-06900-U00.	FOP-9-1
HZV5-91553-010.	E-15-24	HZW1-56110-701.	F-11-13	HZW1-91353-703.	F-11-38	HZW5-16081-010.	E-18-20-17
HZV5-91553-010.	F-3-41	HZW1-56113-701.	F-11-14	HZW1-91354-701.	F-11-39	HZW5-16735-003.	E-18-20-34
HZV5-91553-010.	F-7-23	HZW1-56116-701.	F-11-16	HZW1-91355-701.	F-11-40	HZW5-24810-U01.	FOP-4-3
HZV5-91553-010.	F-7-10-35	HZW1-56130-702.	F-11-20	HZW1-91356-B00.	F-4-34	HZW5-24810-U01.	FOP-4-2-3
HZV5-91553-010.	F-7-20-4	HZW1-56180-701.	F-11-22	HZW1-91356-B00.	FOP-3-13	HZW5-24810-U11.	FOP-4-2-4
HZV5-91553-010.	F-7-30-3	HZW1-56516-000.	F-10-25	HZW1-91357-701.	F-11-41	HZW5-24811-U01.	FOP-4-4
HZV5-91553-010.	F-8-40	HZW1-56532-000.	F-11-24	HZW1-91358-701.	F-11-42	HZW5-24811-U01.	FOP-4-2-5
HZV5-91560-000.	F-10-60	HZW1-56539-000.	F-10-26	HZW1-91361-701.	F-11-43	HZW5-24812-U01.	FOP-4-5
HZV5-91567-000.	F-15-68	HZW1-56851-703.	F-11-25	HZW1-91553-003.	F-15-1-47	HZW5-24812-U01.	FOP-4-2-6
HZV5-91570-000.	F-15-69	HZW1-56860-701.	F-11-26	HZW1-91554-000.	E-14-22	HZW5-24813-U01.	FOP-4-6
HZW7-90951-010.	F-10-56	HZW1-58130-V03.	FOP-8-1	HZW1-91554-000.	E-18-20-53	HZW5-24813-U01.	FOP-4-2-7

HZW5-24813-U21 FOP-4-2-8
 HZW5-24814-U01 FOP-4-7
 HZW5-24814-U01 FOP-4-2-9
 HZW5-24815-U01 FOP-4-8
 HZW5-24816-U01 FOP-4-9
 HZW5-24816-U01 FOP-4-2-10
 HZW5-24816-U01 FOP-4-4-8
 HZW5-24817-U01 FOP-4-10
 HZW5-24817-U01 FOP-4-2-11
 HZW5-24818-U01 FOP-4-11
 HZW5-24818-U01 FOP-4-2-12
 HZW5-24819-U01 FOP-4-12
 HZW5-24819-U01 FOP-4-2-13
 HZW5-24825-U01 FOP-4-14
 HZW5-24825-U01 FOP-4-2-15
 HZW5-24826-U01 FOP-4-15
 HZW5-24826-U01 FOP-4-2-16
 HZW5-24826-U01 FOP-4-4-10
 HZW5-24831-U01 FOP-4-16
 HZW5-24831-U01 FOP-4-2-17
 HZW5-24831-U01 FOP-4-4-12
 HZW5-24832-U01 FOP-4-17
 HZW5-24832-U01 FOP-4-2-18
 HZW5-24832-U01 FOP-4-4-13
 HZW5-24834-U01 FOP-4-18
 HZW5-24834-U21 FOP-4-2-19
 HZW5-32167-650 F-15-1-27
 HZW5-32168-003 E-18-20-45
 HZW5-35370-U02 FOP-4-20
 HZW5-35370-U02 FOP-4-2-22
 HZW5-35370-U12 FOP-4-2-23
 HZW5-50341-010 F-10-17
 HZW5-90018-000 E-2-30
 HZW5-90018-000 F-7-10-24
 HZW5-90021-U00 FOP-9-2
 HZW5-90023-000 F-2-26
 HZW5-90101-U00 FOP-4-22
 HZW5-90101-U00 FOP-4-2-25
 HZW5-90101-U00 FOP-4-4-20
 HZW5-90102-U00 FOP-4-23
 HZW5-90102-U00 FOP-4-2-26
 HZW5-90103-U01 FOP-4-24
 HZW5-90103-U01 FOP-4-2-27
 HZW5-90104-U00 FOP-4-25
 HZW5-90104-U00 FOP-4-2-28
 HZW5-90105-003 F-7-19
 HZW5-90105-U01 FOP-4-26
 HZW5-90105-U01 FOP-4-2-29
 HZW5-90106-000 F-7-20
 HZW5-90106-U00 FOP-4-27
 HZW5-90106-U00 FOP-4-2-30
 HZW5-90107-U00 FOP-4-28
 HZW5-90107-U00 FOP-4-2-31
 HZW5-90108-U00 FOP-4-2-32
 HZW5-90109-000 FOP-6-22
 HZW5-90109-000 FOP-6-1-15
 HZW5-90301-U00 FOP-4-29
 HZW5-90301-U00 FOP-4-2-33
 HZW5-90302-003 F-3-35
 HZW5-90302-003 F-10-39
 HZW5-90302-U21 FOP-4-2-34
 HZW5-90304-000 F-10-42
 HZW5-90501-000 F-2-30
 HZW5-90501-U00 FOP-4-30
 HZW5-90501-U00 FOP-4-2-35
 HZW5-90501-U00 FOP-4-4-26
 HZW5-90502-U00 FOP-4-32
 HZW5-90502-U00 FOP-4-2-37
 HZW5-90503-U00 FOP-4-33
 HZW5-90503-U00 FOP-4-2-38
 HZW5-90511-U00 FOP-9-3
 HZW5-90512-U00 FOP-9-4
 HZW5-90601-030 E-18-20-51
 HZW5-90606-030 E-1-5
 HZW5-91054-003 F-5-21
 HZW5-91202-003 F-3-30-20
 HZW6-87124-U80 FOP-10-58
 HZW6-90752-000 F-10-62
 HZW7-24810-U01 FOP-4-4-2
 HZW7-24811-U01 FOP-4-4-3
 HZW7-24812-U01 FOP-4-4-4
 HZW7-24813-U01 FOP-4-4-5
 HZW7-24814-U01 FOP-4-4-6
 HZW7-24815-U01 FOP-4-4-7
 HZW7-24817-U01 FOP-4-4-9
 HZW7-24832-U01 FOP-4-4-14
 HZW7-24833-U01 FOP-4-4-15
 HZW7-32530-U00 FOP-4-19
 HZW7-32530-U00 FOP-4-2-20
 HZW7-32530-U10 FOP-4-2-21
 HZW7-32530-U20 FOP-4-4-16
 HZW7-35370-U02 FOP-4-4-17
 HZW7-58130-U02 FOP-8-1
 HZW7-58130-U12 FOP-8-1
 HZW7-58130-U22 FOP-8-1
 HZW7-58130-U32 FOP-8-1
 HZW7-87703-U00 FOP-4-4-1
 HZW7-90101-U01 FOP-4-4-21
 HZW7-90102-U01 FOP-4-4-22
 HZW7-90103-U01 FOP-4-4-23
 HZW7-90104-U01 FOP-4-4-24
 HZW7-90301-U01 FOP-4-4-25
 HZW7-90502-U00 FOP-4-4-27
 HZW9-17917-000 FOP-10-3
 HZW9-19279-000 F-3-30-5
 HZW9-19279-000 F-3-30-7
 HZW9-19297-000 F-3-30-9
 HZW9-19300-003 E-3-9
 HZW9-19303-003 E-2-42
 HZW9-19303-003 E-3-36
 HZW9-19315-000 E-2-16
 HZW9-19317-000 E-2-17
 HZW9-19317-000 E-3-11
 HZW9-19317-000 F-3-30-11
 HZW9-28462-003 F-13-2
 HZW9-53103-000 FOP-10-30
 HZW9-53130-000 FOP-10-49
 HZW9-53133-000 FOP-10-50
 HZW9-53165-000 FOP-10-52
 HZW9-87511-000 FOP-10-60
 HZW9-87532-640 FOP-10-61
 HZW9-87702-800 F-15-49
 HZW9-90003-000 E-18-19
 HZW9-90008-000 F-15-50
 HZW9-90009-000 F-10-27
 HZW9-90011-000 E-9-10-7
 HZW9-90011-000 E-18-20
 HZW9-90011-000 E-18-10-17
 HZW9-90011-000 F-2-23
 HZW9-90011-000 F-7-4
 HZW9-90011-000 F-7-18
 HZW9-90011-000 F-7-10-21
 HZW9-90013-000 F-7-5
 HZW9-90013-000 F-7-10-22
 HZW9-90014-000 F-7-6
 HZW9-90016-000 E-3-20
 HZW9-90016-000 E-18-21
 HZW9-90016-000 E-18-20-48
 HZW9-90016-000 E-20-2
 HZW9-90019-000 E-2-31
 HZW9-90101-003 F-3-10-12
 HZW9-90102-000 E-6-9
 HZW9-90102-000 F-4-20
 HZW9-90102-000 FOP-10-64
 HZW9-90103-010 F-3-28
 HZW9-90105-000 F-3-30-17
 HZW9-90105-000 F-10-31
 HZW9-90154-000 F-10-36
 HZW9-91303-000 E-18-23
 HZY1-90205-000 F-3-10-21
 HZY1-90650-003 FOP-11-5
 HZY3-16011-A01 E-18-20-1
 HZY3-16024-000 E-18-20-6
 HZY3-16026-000 E-18-20-7
 HZY3-16072-000 E-18-20-12
 HZY3-16073-000 E-18-20-14
 HZY3-16077-000 E-18-20-16
 HZY3-16082-000 E-18-20-19
 HZY3-16083-000 E-18-20-21
 HZY3-16087-000 E-18-20-22
 HZY3-16193-A00 E-18-20-24
 HZY3-16752-000 E-18-20-37
 HZY3-16752-A00 E-14-6
 HZY3-16807-003 E-18-10-4
 HZY3-16904-003 E-18-10-8
 HZY3-16911-010 E-18-20-40
 HZY3-16915-010 E-18-10-10
 HZY3-16918-003 E-18-10-11
 HZY3-16919-003 E-18-10-12
 HZY3-19270-000 F-8-2
 HZY3-19271-000 F-8-3
 HZY3-19272-000 F-8-4
 HZY3-24318-000 F-4-11
 HZY3-24618-000 F-2-13
 HZY3-24619-000 F-2-15
 HZY3-30280-003 F-11-1
 HZY3-31106-003 F-11-2
 HZY3-32128-000 E-15-10
 HZY3-32411-003 F-7-10-5
 HZY3-35673-003 E-2-24
 HZY3-35673-003 E-3-16
 HZY3-38216-003 F-7-10-10
 HZY3-40119-003 F-3-9
 HZY3-40219-013 F-11-9
 HZY3-63205-000 F-2-22
 HZY3-90016-000 E-9-10-8
 HZY3-90017-000 E-2-29
 HZY3-90017-000 E-9-10-9
 HZY3-90017-000 F-2-25
 HZY3-90021-000 E-18-20-49
 HZY3-90021-000 F-7-10-25
 HZY3-90026-000 E-3-21
 HZY3-90030-000 E-1-4
 HZY3-90030-000 E-2-32
 HZY3-90030-000 E-3-22
 HZY3-90030-000 E-9-10-11
 HZY3-90030-000 F-3-30-14
 HZY3-90031-000 E-3-23
 HZY3-90042-000 E-14-14
 HZY3-90043-000 F-3-30-15
 HZY3-90046-000 E-6-8
 HZY3-90054-000 E-3-24
 HZY3-90054-000 E-14-15
 HZY3-90056-000 F-2-27
 HZY3-90056-000 F-3-30-16
 HZY3-90103-000 FOP-10-66
 HZY3-90107-000 F-7-10-28
 HZY3-90111-000 F-8-27
 HZY3-90120-000 F-3-10-16
 HZY3-90132-000 F-8-30
 HZY3-90133-000 F-3-10-20
 HZY3-90255-000 E-14-17
 HZY3-90405-000 F-7-10-32
 HZY3-90508-000 E-15-20
 HZY3-90508-000 F-2-31
 HZY3-90508-000 F-8-34
 HZY3-90601-030 F-3-30-18
 HZY3-90751-000 F-2-37
 HZY3-91254-003 F-4-32
 HZY3-91303-000 E-21-23
 HZY3-91556-000 F-3-10-31
 HZY6-16016-003 E-15-2
 HZY6-16036-003 E-18-20-8
 HZY6-16718-013 E-18-20-28
 HZY6-16723-003 E-18-20-30
 HZY6-17109-000 E-14-8
 HZY6-17845-000 F-2-3
 HZY6-17931-000 F-2-7
 HZY6-19269-000 E-18-16
 HZY6-19289-000 F-8-5
 HZY6-19290-003 F-3-30-6
 HZY6-19300-003 E-2-15
 HZY6-31235-003 E-21-10
 HZY6-31236-003 E-21-11
 HZY6-36104-003 F-3-5
 HZY6-36135-003 E-18-17
 HZY6-36551-003 E-14-11
 HZY6-40219-023 F-3-12
 HZY6-50209-000 F-3-20
 HZY6-56118-000 F-3-21
 HZY6-90002-000 F-3-26
 HZY6-90006-000 E-15-16
 HZY6-90013-000 E-21-19
 HZY6-90023-000 E-9-10-10
 HZY6-90047-000 E-2-33
 HZY6-90105-000 F-3-30
 HZY6-90123-000 F-3-10-17
 HZY6-90123-000 F-5-13
 HZY6-90301-000 F-8-32
 HZY6-90651-000 F-8-36
 HZY6-90752-000 F-2-38
 HZY6-90753-000 F-2-39
 HZY6-91305-003 E-3-30
 HZY6-91552-000 F-4-36
 HZY6-91552-000 FOP-3-14
 HZY6-91553-000 F-8-41
 HZY9-06167-000 E-18-1
 HZY9-06192-H00 FOP-3-1
 HZY9-06193-H00 FOP-3-2
 HZY9-06411-010 F-3-1
 HZY9-06534-000 F-10-2
 HZY9-11320-010ZA E-6-1
 HZY9-11381-003 E-6-2
 HZY9-11411-405ZA E-9-10-1
 HZY9-11911-000 E-3-3
 HZY9-12000-406ZA E-3-4
 HZY9-12210-H00ZA E-2-5
 HZY9-12251-013 E-2-8
 HZY9-12310-010 E-1-1
 HZY9-12312-000 E-1-2
 HZY9-13010-H00 E-7-1
 HZY9-13011-010 E-7-1
 HZY9-13101-H00 E-7-2
 HZY9-13210-010 E-7-5
 HZY9-13310-010 E-7-7
 HZY9-13331-003 E-7-9
 HZY9-13621-H01 E-7-11
 HZY9-14110-000 E-9-1
 HZY9-14222-000 E-9-4
 HZY9-14430-000 E-9-7
 HZY9-14441-000 E-9-8
 HZY9-14442-000 E-9-9
 HZY9-14510-003 E-9-10
 HZY9-14512-000 E-9-11
 HZY9-14751-H01 E-9-19
 HZY9-14752-003 E-9-20
 HZY9-15100-000 E-5-1
 HZY9-15121-000 E-5-2
 HZY9-15136-000 E-5-3
 HZY9-15171-000 E-15-1
 HZY9-15220-000 E-6-3
 HZY9-15422-010 E-1-3
 HZY9-15600-000 E-3-6
 HZY9-15612-000 E-3-7
 HZY9-15631-000 E-3-8
 HZY9-15655-000 E-6-4
 HZY9-15665-000 F-3-30-1
 HZY9-15815-000 E-2-12
 HZY9-16013-000 E-18-20-2
 HZY9-16017-040 E-18-20-3
 HZY9-16019-003 E-18-20-4
 HZY9-16020-013 E-18-20-5
 HZY9-16042-013 E-18-20-9
 HZY9-16061-003 E-18-20-10
 HZY9-16071-003 E-18-20-11
 HZY9-16072-003 E-18-20-13
 HZY9-16073-003 E-18-20-15
 HZY9-16081-003 E-18-20-18
 HZY9-16082-003 E-18-20-20
 HZY9-16195-000 E-18-2
 HZY9-16196-000 E-18-3
 HZY9-16197-000 E-18-4
 HZY9-16198-000 E-18-5
 HZY9-16199-000 E-18-6
 HZY9-16400-H01 E-15-3
 HZY9-16450-003 E-14-1
 HZY9-16451-000 E-14-2
 HZY9-16620-010 E-14-3
 HZY9-16700-013 E-18-7
 HZY9-16701-003 E-18-20-25
 HZY9-16708-003 E-18-20-26
 HZY9-16715-013 E-18-20-27
 HZY9-16717-000 E-2-13
 HZY9-16721-003 E-18-20-29
 HZY9-16730-063 E-18-20-31
 HZY9-16733-000 E-14-5
 HZY9-16733-000 E-18-20-32
 HZY9-16734-010 E-18-20-33
 HZY9-16740-003 E-18-20-35
 HZY9-16755-003 E-18-8
 HZY9-16756-000 E-18-9
 HZY9-16800-003 E-18-10-2

HZY9-16805-003.	E-18-10-3	HZY9-32112-000.	E-18-10-15	HZY9-82874-000.	F-8-23	HZZ3-32346-R21	FOP-6-6
HZY9-16816-000.	E-18-10	HZY9-32113-000.	E-9-10-3	HZY9-87117-000.	F-12-1	HZZ3-32346-R31	FOP-6-1-3
HZY9-16850-E01.	E-18-10-5	HZY9-32114-000.	E-2-22	HZY9-87121-R00.	F-12-2	HZZ3-32347-R01	FOP-6-7
HZY9-16860-F00.	E-18-10-6	HZY9-32115-000.	E-9-10-4	HZY9-87132-R00.	F-12-6	HZZ3-35100-R01	FOP-10-17
HZY9-16871-F00.	E-18-10-7	HZY9-32166-013.	E-18-20-44	HZY9-87133-R00.	F-12-17	HZZ3-35100-R11	F-15-39
HZY9-16881-010.	E-18-11	HZY9-32410-000.	F-7-10-4	HZY9-87531-000.	F-12-13	HZZ3-35100-R11	FOP-6-13
HZY9-16891-000.	E-18-12	HZY9-32418-000.	F-7-10-6	HZY9-87546-000.	F-12-16	HZZ3-35100-R11	FOP-6-1-7
HZY9-16895-003.	E-18-13	HZY9-32534-A01	FOP-10-9	HZY9-90003-000.	E-14-12	HZZ3-35340-741.	FOP-12-1
HZY9-16896-003.	E-2-14	HZY9-32538-A01	FOP-10-10	HZY9-90008-003.	E-3-17	HZZ3-35341-740.	FOP-12-2
HZY9-16896-003.	E-15-4	HZY9-34750-H01	E-20-10-9	HZY9-90011-000.	E-2-27	HZZ3-35342-740.	FOP-12-3
HZY9-16896-003.	E-18-14	HZY9-34754-H00	E-20-10-4	HZY9-90011-H00	E-20-10-11	HZZ3-35343-740.	FOP-12-4
HZY9-16896-003.	E-18-20-38	HZY9-35470-023.	F-2-19	HZY9-90016-000.	E-2-28	HZZ3-35344-740.	FOP-12-5
HZY9-16898-003.	E-18-20-39	HZY9-35475-010.	F-2-20	HZY9-90017-000.	E-15-17	HZZ3-35345-741.	FOP-12-6
HZY9-16910-004.	E-18-10-9	HZY9-35640-003.	F-8-6	HZY9-90102-000.	F-3-27	HZZ3-37205-R01	FOP-6-17
HZY9-16913-003.	E-18-20-41	HZY9-35645-000.	F-8-7	HZY9-90102-000.	F-10-29	HZZ3-87301-R00	F-12-18
HZY9-17110-003.	E-14-9	HZY9-35655-H01	E-2-23	HZY9-90103-000.	F-8-25	HZZ3-87701-R00	F-15-48
HZY9-17315-000.	E-15-6	HZY9-35660-003.	F-10-5	HZY9-90104-000.	F-3-29	HZZ3-87701-R40	FOP-4-4-18
HZY9-17371-000.	E-15-7	HZY9-35695-003.	E-2-25	HZY9-90105-000.	F-3-31	HZZ3-87703-R01	FOP-4-2-24
HZY9-17371-H00	E-15-7	HZY9-36104-003.	F-11-3	HZY9-90106-000.	F-8-26	HZZ3-87703-R81	FOP-4-2-1
HZY9-17374-000.	E-15-8	HZY9-36120-003.	F-11-4	HZY9-90113-003.	F-8-28	HZZ3-90129-000.	F-10-34
HZY9-17723-F00.	E-18-20-42	HZY9-36129-003.	F-11-7	HZY9-90201-000.	E-3-26	HZZ3-90651-003.	F-3-38
HZY9-17840-000.	F-2-2	HZY9-36550-003.	E-14-10	HZY9-90508-000.	F-2-32	HZZ3-91252-003.	F-5-23
HZY9-17860-000.	F-2-4	HZY9-37210-A02	FOP-10-24	HZY9-90509-000.	F-2-33	HZZ3-91253-003.	F-4-31
HZY9-17877-000.	F-2-5	HZY9-38201-003.	F-7-13	HZY9-90651-000.	F-2-35	HZZ5-06325-000.	FOP-6-2
HZY9-17878-000.	F-2-6	HZY9-38216-003.	F-7-14	HZY9-90652-003.	F-7-7	HZZ5-06325-700.	FOP-6-2
HZY9-17910-701.	FOP-10-2	HZY9-38217-000.	F-7-10-12	HZY9-90751-000.	F-8-37	HZZ5-06325-800.	FOP-6-2
HZY9-18211-000.	F-8-1	HZY9-38233-000.	F-7-15	HZY9-90754-000.	F-3-39	HZZ5-32185-600.	FOP-6-4
HZY9-19210-H01	F-4-1	HZY9-38400-A00	FOP-10-25	HZY9-90755-000.	F-8-38	HZZ5-32185-700.	FOP-6-4
HZY9-19210-H01	FOP-3-3	HZY9-38402-A00	FOP-10-26	HZY9-90951-A01	FOP-10-87	HZZ5-32185-800.	FOP-6-4
HZY9-19221-H00	F-4-2	HZY9-38550-003.	F-7-10-14	HZY9-91304-000.	E-5-15	HZZ5-32530-000.	F-15-35
HZY9-19221-H00	FOP-3-4	HZY9-38552-000.	F-7-10-16	HZY9-91402-000.	F-3-30-23	HZZ5-32545-000.	FOP-6-8
HZY9-19223-H00	F-4-3	HZY9-38553-003.	F-7-10-17	HZY9-91403-000.	E-15-21	HZZ5-32545-000.	FOP-6-1-4
HZY9-19223-H00	FOP-3-5	HZY9-38580-003.	F-7-10-18	HZY9-91404-000.	E-15-22	HZZ5-32580-600.	FOP-6-9
HZY9-19231-H00	F-4-4	HZY9-40105-000.	F-3-7	HZY9-91405-000.	E-15-23	HZZ5-32580-700.	FOP-6-9
HZY9-19231-H00	FOP-3-6	HZY9-40105-A00	FOP-10-27	HZY9-91451-A00	FOP-10-92	HZZ5-32580-800.	FOP-6-9
HZY9-19251-000.	F-4-8	HZY9-40151-000ZC.	F-8-9	HZY9-91552-000.	F-8-39	HZZ5-37210-013.	F-15-45
HZY9-19251-610.	F-4-8	HZY9-40154-000ZC.	F-3-10	HZY9-91553-000.	F-3-42	HZZ5-37210-712.	FOP-6-1-11
HZY9-19254-000.	E-6-6	HZY9-40155-010.	F-8-10	HZY9-91554-000.	F-8-42	HZZ5-37210-762.	FOP-6-18
HZY9-19255-000.	E-18-20-43	HZY9-40165-010.	F-8-11	HZY9-91555-000.	F-7-10-36	HZZ5-38414-003.	FOP-6-21
HZY9-19256-000.	F-3-30-3	HZY9-40201-020ZC.	F-3-11	HZY9-91557-000.	F-10-59	HZZ5-38414-003.	FOP-6-1-14
HZY9-19277-000.	F-3-30-4	HZY9-40202-H50ZB.	F-3-10-2	HZY9-91601-000.	E-6-16	HZZ5-50211-000.	F-10-13
HZY9-19295-000.	F-3-30-8	HZY9-41100-H00ZB.	F-3-20-1	HZZ0-06533-R00ZA.	FOP-10-1		
HZY9-19315-H00	E-3-10	HZY9-41100-H50ZB.	F-3-20-1	HZZ0-13102-000.	E-7-2		
HZY9-19361-010.	E-2-18	HZY9-41101-H00ZB.	F-3-10-4	HZZ0-14110-000.	E-9-1		
HZY9-19371-000.	E-2-19	HZY9-41151-H00	F-5-9	HZZ0-14420-000.	E-9-6		
HZY9-23170-010ZA.	F-3-30-12	HZY9-41173-000.	F-3-14	HZZ0-15810-003ZA.	E-2-10		
HZY9-23172-003.	E-6-7	HZY9-50100-020.	F-10-6	HZZ0-19241-000.	F-4-6		
HZY9-24221-000.	F-2-10	HZY9-50111-000ZC.	F-3-15	HZZ0-24101-010.	F-5-1		
HZY9-24320-610.	F-4-12	HZY9-50153-000.	F-10-8	HZZ0-24113-000.	F-5-4		
HZY9-24343-H00	F-4-14	HZY9-50156-000.	F-3-17	HZZ0-24122-000.	F-5-5		
HZY9-24590-701.	FOP-10-5	HZY9-50157-000.	F-3-18	HZZ0-24123-000.	F-5-6		
HZY9-24612-000.	F-2-11	HZY9-50158-000.	F-10-9	HZZ0-24124-000.	F-5-7		
HZY9-24614-000.	F-2-12	HZY9-50166-010.	F-10-10	HZZ0-24310-000.	F-4-10		
HZY9-24618-000.	F-2-14	HZY9-50168-000.	F-10-11	HZZ0-32100-H00	F-7-1		
HZY9-24628-000.	F-2-16	HZY9-50201-H00ZB.	F-10-12	HZZ0-34750-H01	E-20-10-9		
HZY9-24630-000.	F-2-18	HZY9-50301-020ZC.	F-10-15	HZZ0-41102-000.	F-3-10-6		
HZY9-30416-H00	F-7-20-1	HZY9-50311-020ZC.	F-10-16	HZZ0-41103-000.	F-3-10-7		
HZY9-30419-003.	E-15-9	HZY9-50381-000.	F-10-18	HZZ0-41104-010.	F-3-10-8		
HZY9-30419-003.	F-7-20-2	HZY9-50412-000.	F-10-19	HZZ0-41105-010.	F-3-10-9		
HZY9-31110-000ZB.	E-7-12	HZY9-53101-A02ZD	FOP-10-28	HZZ0-41107-000ZD.	F-3-10-10		
HZY9-31145-000.	F-7-30-1	HZY9-53102-A02	FOP-10-29	HZZ0-41140-010.	F-5-8		
HZY9-31200-H01	E-21-1	HZY9-53105-A01	FOP-10-33	HZZ0-41160-010.	F-5-10		
HZY9-31207-H01	E-21-2	HZY9-53108-A00	FOP-10-36	HZZ0-41161-000.	F-5-11		
HZY9-31216-003.	E-21-4	HZY9-53232-A00	FOP-10-53	HZZ0-50151-000.	F-10-7		
HZY9-31226-H01	E-21-20	HZY9-53233-A00ZD	FOP-10-54	HZZ0-50155-000.	F-3-16		
HZY9-31227-H01	E-21-7	HZY9-56000-013.	F-11-11	HZZ0-58130-D81ZB.	FOP-8-1		
HZY9-31229-H01	E-21-8	HZY9-56100-013.	F-11-12	HZZ0-58130-D91ZB.	FOP-8-1		
HZY9-31231-H01	E-21-9	HZY9-56115-003.	F-11-15	HZZ0-87121-R00	F-12-3		
HZY9-31240-003.	E-21-12	HZY9-56120-003.	F-11-19	HZZ0-87125-R00	FOP-10-59		
HZY9-31242-H01	E-21-13	HZY9-56170-003.	F-11-21	HZZ0-90101-000.	F-3-10-13		
HZY9-31246-H01	E-21-14	HZY9-58130-H01ZB.	FOP-8-1	HZZ3-06240-R30	FOP-4-1		
HZY9-31251-H01	E-21-24	HZY9-63100-020ZC.	F-8-13	HZZ3-06240-R40	FOP-4-4-1		
HZY9-31630-H01	E-19-1	HZY9-63102-000.	F-8-14	HZZ3-06240-R60	FOP-4-2-1		
HZY9-31631-H01	E-19-2	HZY9-63232-010.	F-3-22	HZZ3-06323-R20	FOP-6-1		
HZY9-31632-003.	E-19-3	HZY9-63232-010.	F-8-15	HZZ3-06323-R30	FOP-6-1-1		
HZY9-31750-003.	E-2-20	HZY9-63237-000.	F-3-23	HZZ3-06328-763.	FOP-11-1		
HZY9-31754-000.	E-2-21	HZY9-63237-000.	F-8-16	HZZ3-24800-R00	F-15-2		
HZY9-31916-H01	E-20-3	HZY9-63347-010ZC.	F-8-17	HZZ3-24820-R11	FOP-4-13		
HZY9-32100-H00	F-7-1	HZY9-63711-010ZC.	F-8-18	HZZ3-24820-R21	FOP-4-2-14		
HZY9-32101-000.	F-7-2	HZY9-63716-010ZC.	F-8-19	HZZ3-24830-R41	FOP-4-4-11		
HZY9-32103-000.	F-7-3	HZY9-63718-000.	F-3-30-13	HZZ3-32127-000.	F-7-12		
HZY9-32104-H00	F-7-11	HZY9-63719-000.	F-3-25	HZZ3-32186-000.	FOP-11-2		
HZY9-32111-000.	E-9-10-2	HZY9-82873-000.	F-8-22	HZZ3-32341-R31	FOP-6-5		

Note

Note

Note

TOHATSU CORPORATION

**Address : 5-4,3-chome,Azusawa,Itabashi-ku,
TOKYO,174-0051 JAPAN**

Phone : TOKYO (03)3966-3117

FAX : TOKYO (03)3966-0090

Website : www.tohatsu.co.jp

**2016
PARTS CATALOG**

**BFT 75A
BFT 90A**